



Industrial Pharmacy



Mixing



Solid Dose Form Operations

- Weighing
 - Dispensing/Pharmacy/
 - Subdivision
- Mixing
 - Dry Blend
 - Wet Blend
- Particle Sizing
 - Screening
 - Milling
 - Micronizing
- Granulation/Drying/Coating
 - High Shear
 - Fluidized Bed
 - Compaction
 - Micro-encapsulation

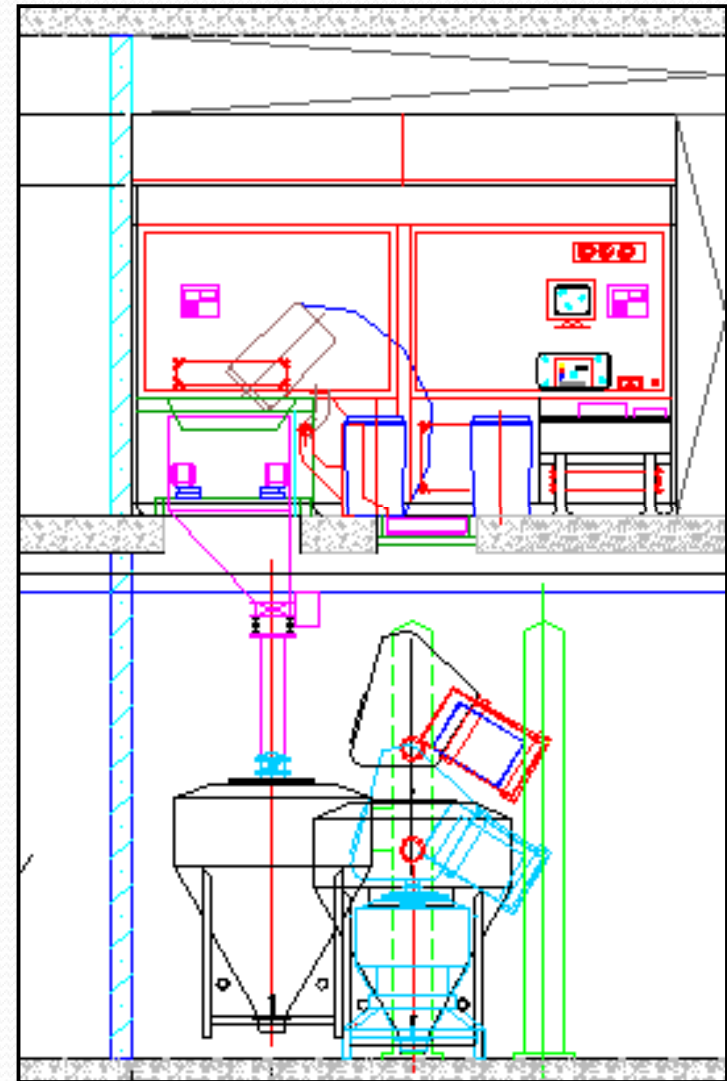

Solid Dosage Process Flow

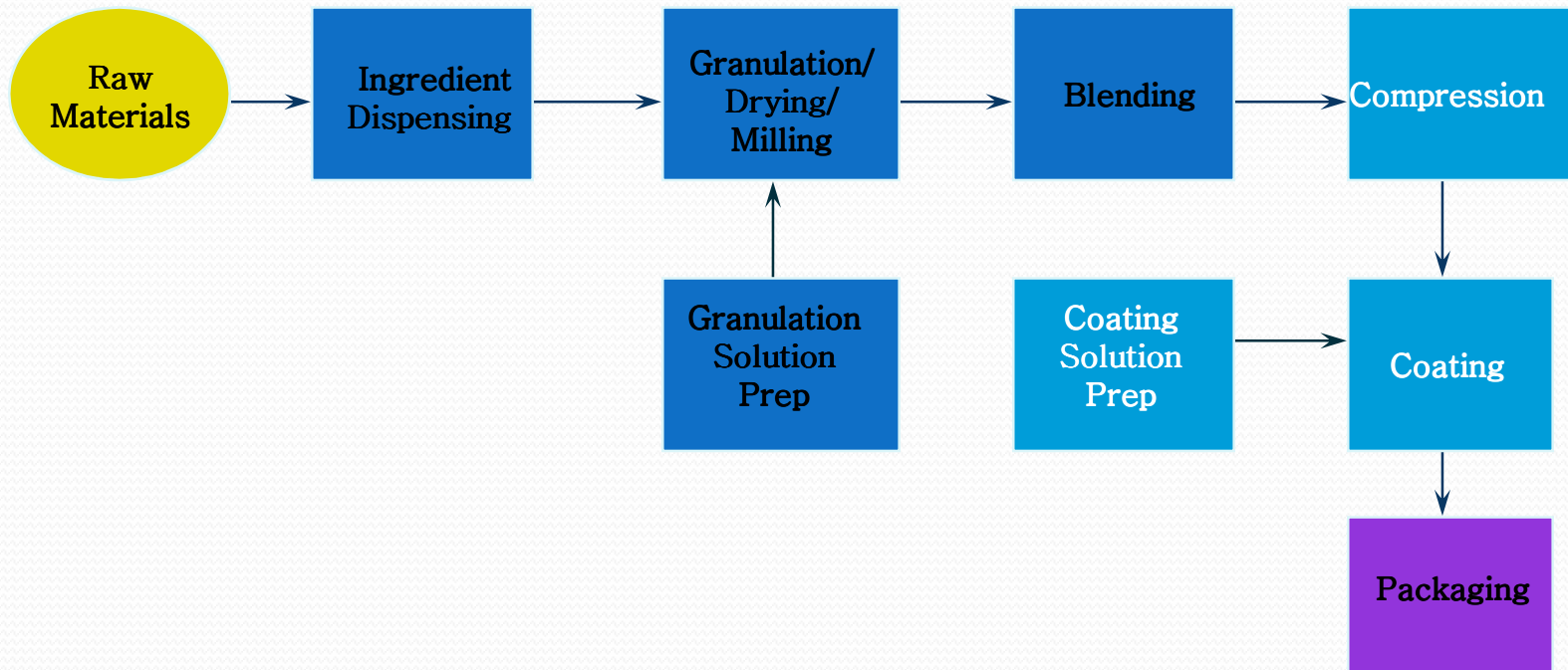

Outline of the lecture:

- ❑ **Mixing**
- ❑ Definition and objectives
- ❑ Mixing equipment
- ❑ Impellers for liquids
- ❑ Mixers of dry powders
 - Factors affecting mixing of solids
 1. Tumbling mixers
 2. Agitator mixers
 3. Special mixers for powders
 4. Entolator impact when mixer
 5. Pneumatic mixer
 6. V-type mixer
- ❑ Mixers for semisolids
 - Types of flow in semisolids
 1. Beaters
 2. Kneaders
 3. Mixer-Extruders



Definition:

It is the intermingling of two or more dissimilar portions of materials resulting in attainment of a desired level of uniformity either physically or chemically.

Perfect mixing:

It is that state in which any sample removed from the mixture will have exactly the same composition as any sample taken from any point of the mixture.



Random mixing:

It is the state in which there is a probability of finding the particles of a given component the same at all points in the mixture and is in the same ratio of components in the entire mixture.

Objectives of mixing:

Attainment of complete and mutual distribution of the constituent materials.

Increasing the contact surface thus promoting chemical and physical reactions.



Mixing equipment:

These are classified according to materials intended to be mixed into:

1. Impellers for liquids
2. Mixers for powders
3. Mixers for semisolids or pastes.

Outline of the lecture:

- ❑ **Mixing**
- ❑ Definition and objectives
- ❑ Mixing equipment
- ❑ Impellers for liquids
- ❑ Mixers of dry powders
 - Factors affecting mixing of solids
 - Tumbling mixers
 - Agitator mixers
 - Special mixers for powders
 - Entolator impact when mixer
 - Pneumatic mixer
 - V-type mixer
- ❑ Mixers for semisolids
 - Types of flow in semisolids
 - Beaters
 - Kneaders
 - Mixer-Extruders



I. Impellers for liquids

There are three types:

1- Paddle 2- Turbine 3- Propeller

The performance for impeller mixer depends on :

- Creation of a current or stream of liquid which penetrate to all point of mixing vessel or tank.
- Turbulence movement to carry the current in all places of the tank.

Types of flow in liquids:

1. **Tangential flow (Rotational):** the liquid flows as circles around the impeller shaft.
2. **Radial flow:** flow of liquid in a direction to-ward the walls of the tank verti-cal to the impeller shaft.
1. **Axial or longitudinal flow:** flow of liquid up and down parallel to the impeller shaft

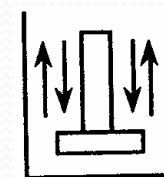
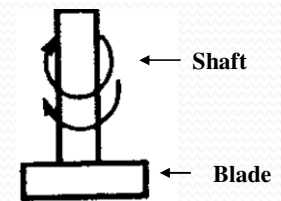

Propeller mixers for liquids:

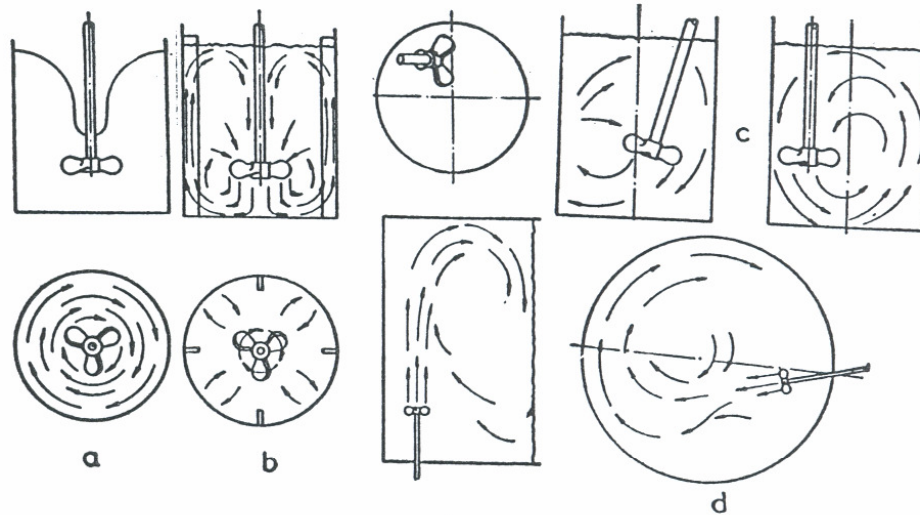

- ❖ (a) propeller centered, vertical, unbaffled ; (b) pro-peller central vertical, baffled ; (c) propeller off center, inclined, unbaffled; (d) side- entering arrangement for large tanks .
- ❖ The three types may exist and in this case efficient mixing occurs.

Disadvantage of tangential flow:

If the tangential flow predominates, vortex forms also symmetry of apparatus (i.e. presence of shaft in center) leads to vortex formation.

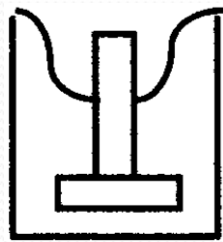

Vortex



Sever Vortex

Disadvantages of vortex:

1. No real mixing.
2. Settling of solid particles in the bottom and no dissolution
3. Air may be entrapped in solution causing degradation of oxidisable materials.

Suppression of vortex:

To avoid vortex formation:

(1) **In small tanks:** Off-centering of the shaft or put the shaft inclined

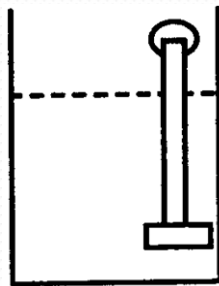

Off centering of shaft

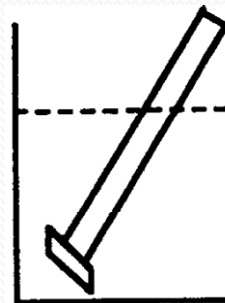

Inclined shaft

(2) In large tanks: One use baffles on the wall or near to it

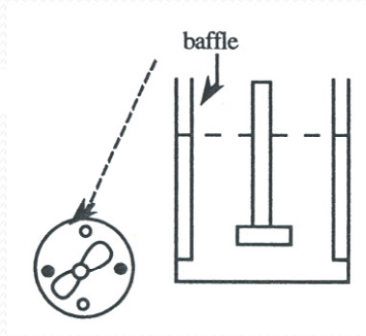

3) In very large tanks : The shaft is introduced from the side of the tank in a horizontal position.

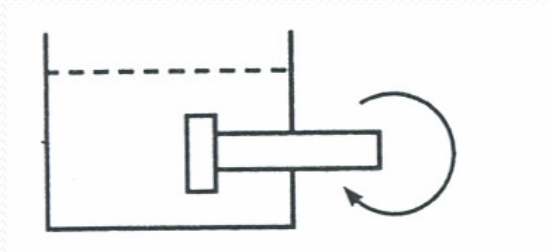

Types of impellers for mixing liquid dosage forms:

1- Paddles

- ✓ Revolution 20 -120 (r.p.m)
- ✓ The current are tangential and radial, there is no axial current.
- ✓ The diameter of the shaft is 50 - 80 % of the di-iameter of mixing tank
- ✓ Width of the blade is $1/6 - 1/10$ its length.
- ✓ It is suitable for mixing thin liquids having viscosity of about 1000 centi-poise.

single

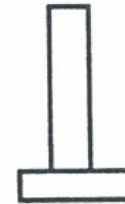

double



Gate Paddle can be used for viscous liquids

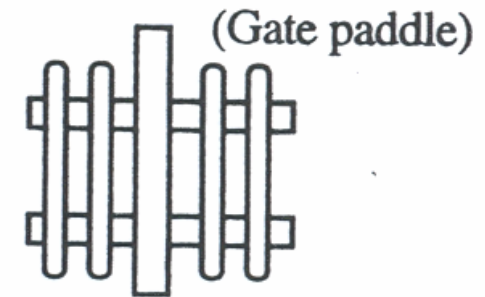

Disadvantages:

1. It Cannot be used for liquids with viscosities more than 1000 centi-poises.
2. They are ineffective in suspending heavy solids because of absence of axial flow.

2- Turbines

- Resemble paddles but the blades are more.
- **Revolution:** 110 - 200 revolution/min.
- **Diameter of the shaft:** 30 - 50% of the inside diameter of the container

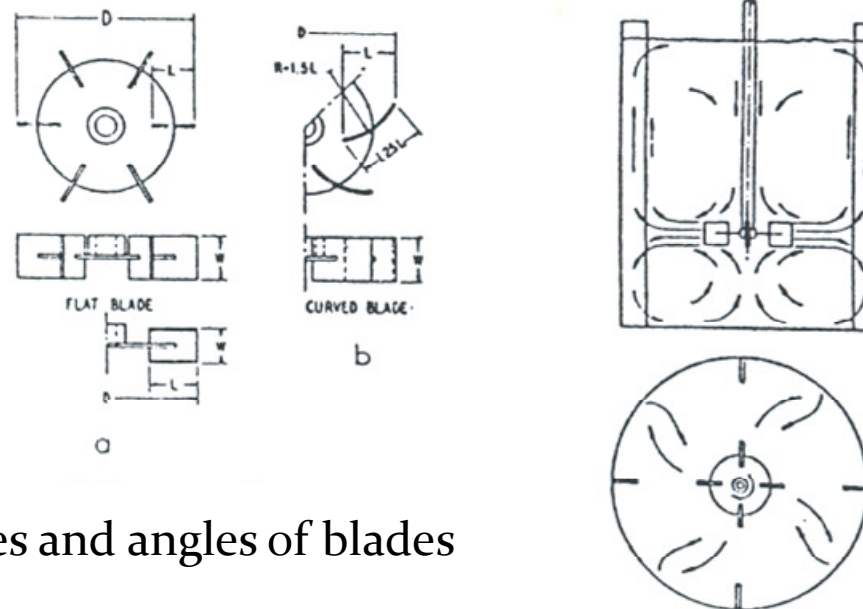

Orientation of baffles and angles of blades

The blades may be straight, curved, vertical or pitched (inclined with angle 45°).



(Curved)

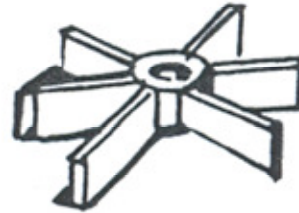

(Pitched)

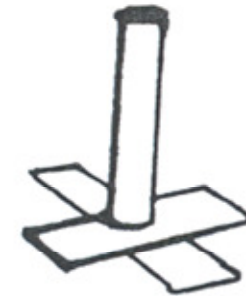

(Straight)

- The currents in these turbines may be radial and tangential (increasing velocity cause increase in the radial current)
- The turbine mixers are effective in mixing liquids with viscosities up to 100,000 centipoises.

3- Propellers

a - Aircraft propeller

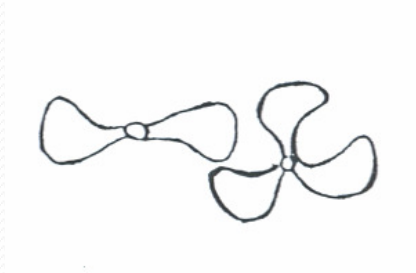

b- Marine Propeller



- ❖ **Revolution:** 400 - 1750 revolution / min.
- ❖ **Currents:** Axial and tangential
- ❖ **Uses:** They are used for suspending heavy solid particles to be kept in suspension. Also they are suitable for rapid mixing of thin liquids. They are not used for liquids having viscosities more than 5000 centipoises (due to absence of radial flow)

Special mixers for liquids

Cone mixer:

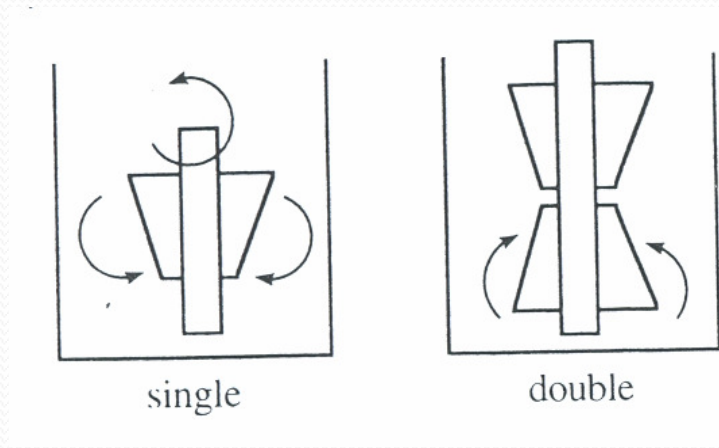

Moves with higher speeds so give efficient mixing.

Disc impeller :Round discs of different configuration are mounted on the rotating shaft to increase mixing efficiency.

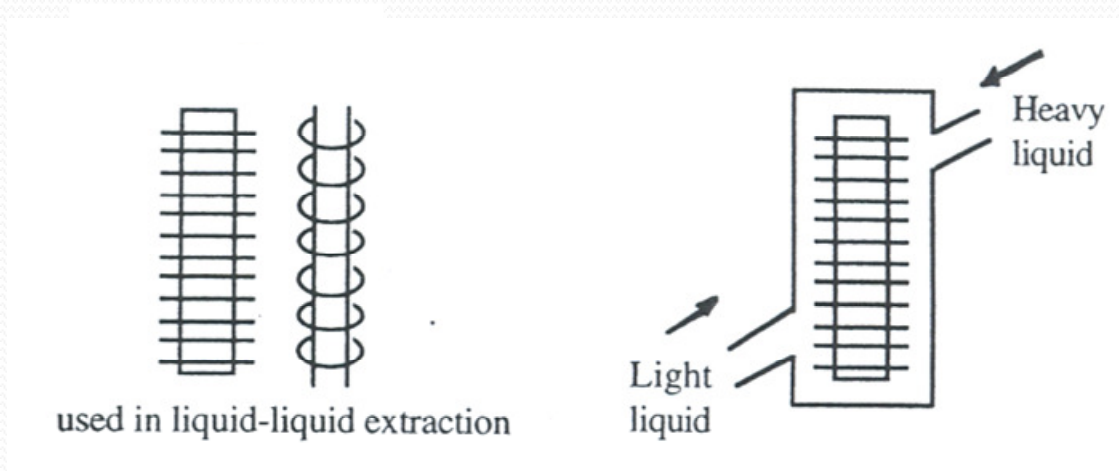

In mixing of syrups , liquid dosage forms light suspensions in pharmaceutical industry, one use the stainless steel steam jacketed mixing tanks.



II. Mixers for dry powders

Purposes of dry powder mixing:

- A. For preparation of multidose dry powder, e.g., effervescent salts or antacids. So the constituents must be well mixed to give a uniform dose.
- B. Mixing of ingredients before compressed as tablets or filled into capsules or for preparing any solid dosage form.



Scale of Scruting:

It is the smallest amount of a drug that can be mixed well. If the dose of the drug in the mixture is less than the scale of scruting, the normal mixing methods fail to attain efficient mixing. In this case geometric, i.e., dilution mixing must be adopted.

Mechanisms of Powder mixing:

During the mixing process of dry powder the particles may be subjected to three types of forces :

- 1- Compression
- 2- Tensile force (Tension)
- 3- Shear(change in the positions of the mixture components)

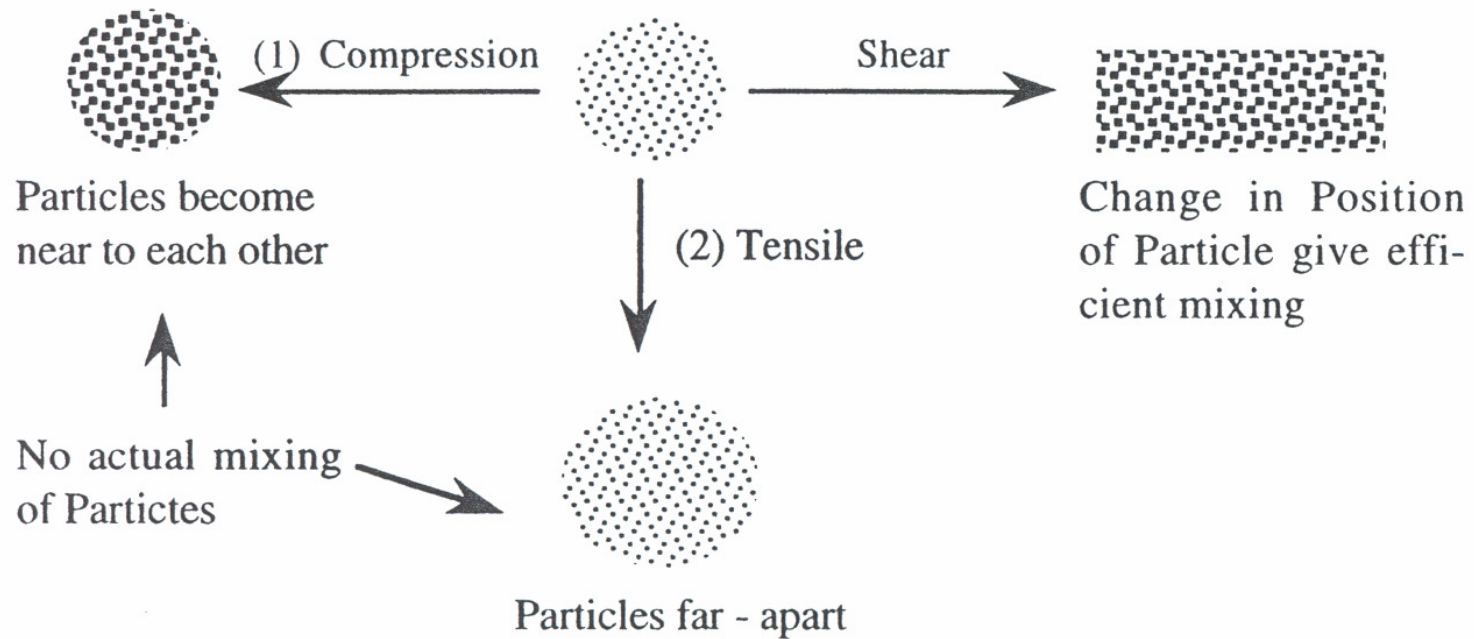

- ❑ In mixing of powder one need for application of shearing force to change the position of particles and give efficient overall movement of particle.
- ❑ Localized shear forces are applied as agitator or ribbon. This cause overall movement of powder giving efficient mixing, but may cause some sort of size reduction which would be undesirable.



Factors affecting mixing of solids:

1. Particle size:

- ✓ The particle sizes must be nearly similar in all particles of the mixture.
- ✓ Increasing the difference in particle size will lead to segregation (size separation), since small particles can fall through the voids between the larger particles.
- ✓ Constant movement of the mixer may lead to suspension of fine particles in air. So stop the mixer immediately or remove the air.



2- Density

- ❖ The difference in densities among mixed particles will lead to segregation. The heavy particles settle down while light ones will rise up.
- ❖ This is aggravated if the heavy particles are coarse and the light particles are finer
- ❖ So mixed particles would be equal in density to attain good mixing.



3- Electrostatic charges:

- These charges are formed due to constant friction among the mixed particles.
- Similar charges repel particles from each others leading to segregation.
- This can be overcome by:
 1. Stopping the mixing equipment. (no increase in time of mixing)
 2. Adding wetting agent or surface active agent which neutralize similar developed charges on the particles
 3. Adding some water and evaporate it after the mixing operation is completed (if water do not affect stability of components)



Conditions to for good mixing

1. Capacity of mixer: the mixer must not be overfilled or low - filled.
Overfilling reduces the efficiency and do not allow sufficient space for dilation of the powder. Overfilling prevents the movements of the powders.
2. Application of shear force to cause change of the posi-tion of powders so give complete and efficient mixing.
3. Optimum time for mixing (determined by experience). Increasing the time of mixing will cause segregation while decreasing the time of mixing will not give complete mixing.
4. Light handling of powder to prevent segregation.
5. Mixer operates in three dimensions

Outline of the lecture:

- ❑ **Mixing**
- ❑ Definition and objectives
- ❑ Mixing equipment
- ❑ Impellers for liquids
- ❑ Mixers of dry powders
 - Factors affecting mixing of solids
 - 1. **Tumbling mixers**
 - 2. Agitator mixers
 - 3. Special mixers for powders
 - 4. Entolator impact when mixer
 - 5. Pneumatic mixer
 - 6. V-type mixer
- ❑ Mixers for semisolids
 - Types of flow in semisolids
 - 1. Beaters
 - 2. Kneaders
 - 3. Mixer-Extruders

Type of mixers for powder

I- *Tumbling mixers:*

Here, the movement of particles occurs by tilting the material beyond angle of repose using gravity to impel flow

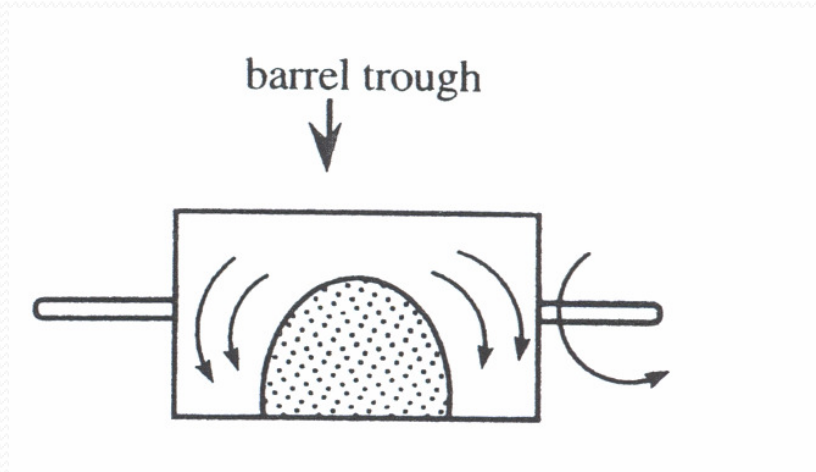

1- Tumbling barrel or drum mixer :

- Consist of cylindrical vessel rotating on its horizontal axis. Gravity impels flow.
- To increase the efficiency, put the mixer in-clined.
- It gives light movement so it is suitable for friable particles when. Disadvantageous in low shear force

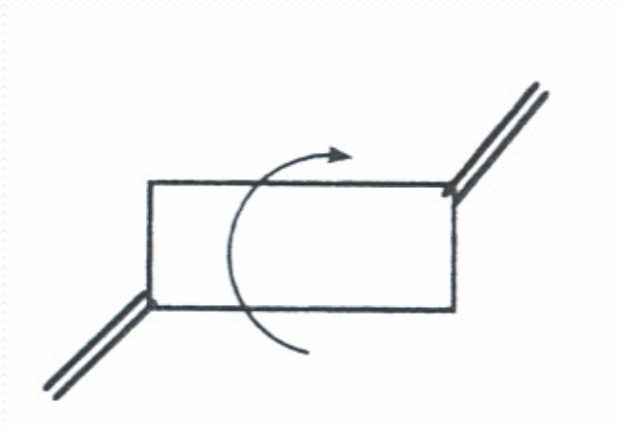

2- Cubical - shaped blender

Mixing occurs by sliding of powder on its wall and gives mixing in three di-mensions if hanged from the corner.

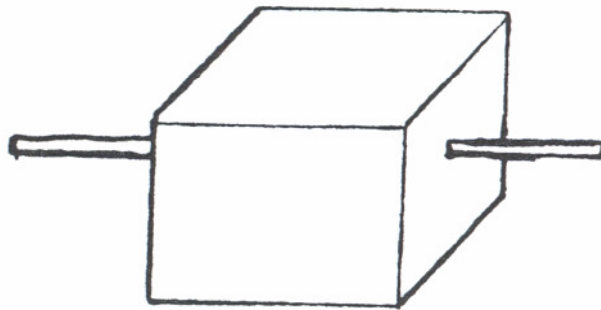

Disadvantages:

1. Difficult in cleaning due to presence of different corners.
2. Sliding action causes abrasion of particles

3- Double cone blender: Composed of two cones joined to short cylindrical section. It is easily cleaned. It is charged by 50 % of its capacity by powder to ensure complete transfer of powder in the two cones.

Advantages:

1. No dead spots in mixing
2. It is easily cleaned,
3. It contains no corners.

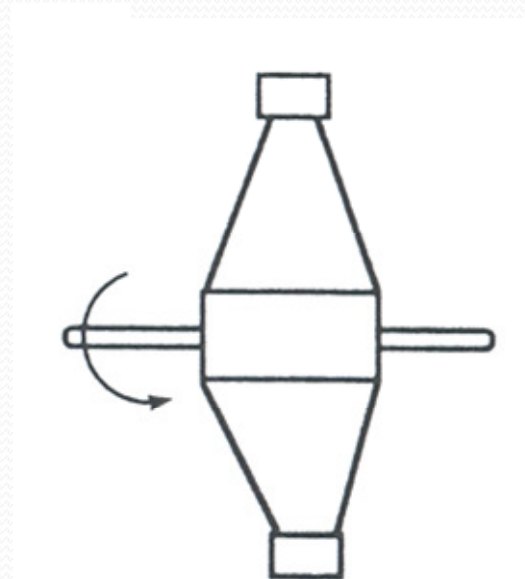

4- Twin -shell or V -shaped mixer: It gives more efficient and more pre-cise mixing due to high shearing force

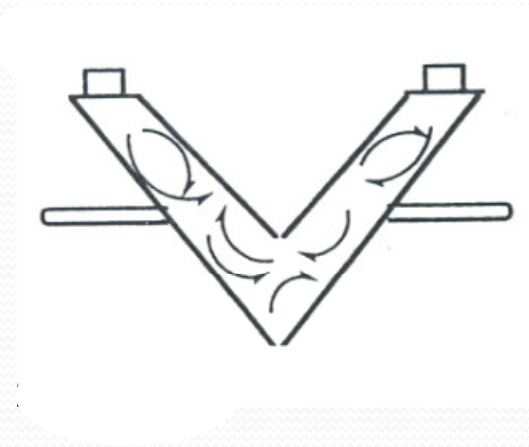



Factors for good mixing in tumbling mixers:

1. Capacity of the mixer must not more than 50% of its capacity.
2. optimum time of mixing.
3. Optimum speed of the mixer ,increasing the speed causes adhesion of powder on the walls of the mixer.
4. Light handling of the powders to minimize size reduction.
5. The method of charging the powders in the tumbling mixers is important: The materials must not be placed in layers. If placed in layers, mixing will affect the upper layer only. So, materials are pre-mixed or put side - by - side and mixing starts immediately.



Advantages of tumbling mixers:

1. They are mild equipment (not aggressive). Thus they are suitable for friable materials.
2. They are preferable when different particle sizes and densities powders are to be mixed due to repeated reversal of direction of flow.
3. If some mixers trough contains an arm which rotates to transmit shearing action to particles representing an advantage.

- 
- ❑ **Mixing**
 - ❑ Definition and objectives
 - ❑ Mixing equipment
 - ❑ Impellers for liquids
 - ❑ Mixers of dry powders
 - Factors affecting mixing of solids
 - 1. Tumbling mixers
 - 2. **Agitator mixers**
 - 3. Special mixers for powders
 - 4. Entolator impact when mixer
 - 5. Pneumatic mixer
 - 6. V-type mixer
 - ❑ Mixers for semisolids
 - Types of flow in semisolids
 - 1. Beaters
 - 2. Kneaders
 - 3. Mixer-Extruders

II. Agitators mixers:

In these mixers, shear is applied by means of agitating ribbon force.

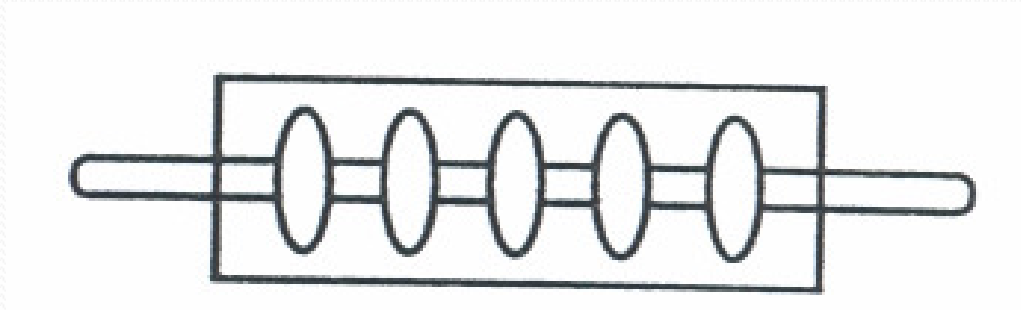

Example : Ribbon blender

Ribbon blender:

There is an outer spiral ribbon to move the materials in one direction and an inner spiral ribbon to move materials in the opposite direction.

The outer ribbon must have a fairly close clearance with the wall so no material remains in the bottom surface.

It is used for blending of materials (or powders) tend to aggregate or don't flow freely.

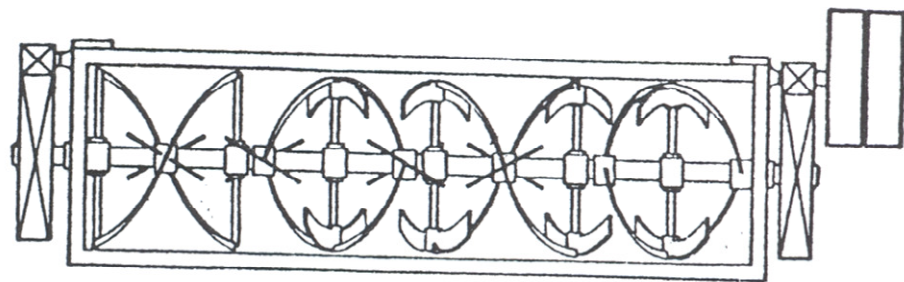

Dry Mixer



Disadvantages:

1. It is not precise .
2. Consumption of powder is more than that in tumbling.
3. Grinding of materials may occur.
4. It is not used for fragile particles

3- Special Mixers for Powder

1. Impact wheel mixer.
2. Pneumatic mixer.

4. Entolator impact wheel mixer:

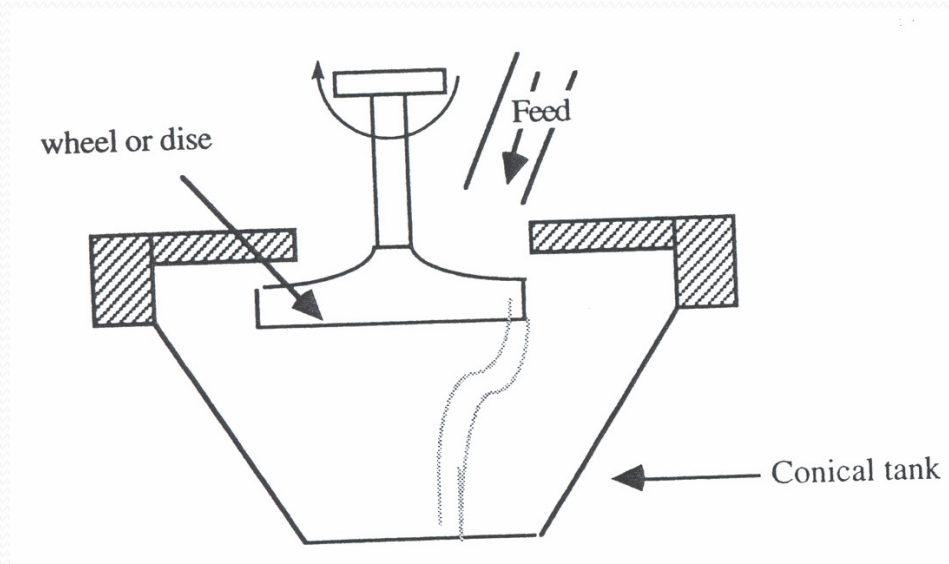

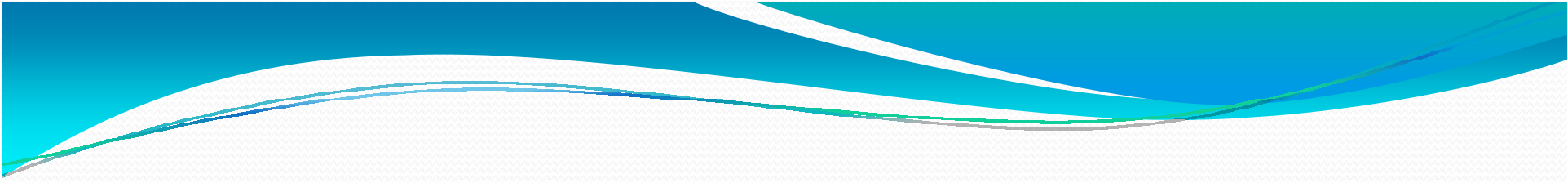
- 
- This is based on rotating a disc or a wheel 20-68 cm in diameter, rotate 1750 - 3500 revolution / min.
 - The materials are feed from above in the center of the disc. The shear force developed cause continuous powder mixing.
 - The particles of powder are then ejected by the centrifugal force from the disc periphery onto the walls of a conical tank which gives the mix-ture a spiral movement towards the bottom

4- Pneumatic mixer: (Airmix mixer)

Here, the driving force is the compressed air which is introduced through nozzles present at the lower part. These nozzles are arranged in a manner that escaped air stream in a vertical motion gives a chance for powder to settle.

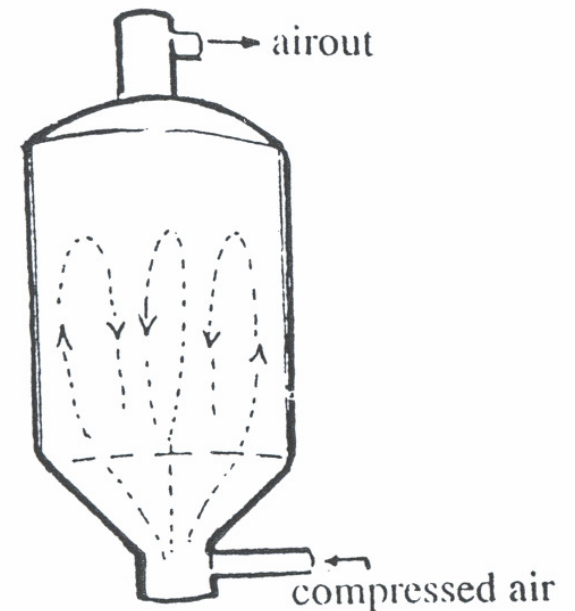



Evaluation of a blend of powder after mixing :

1. The sample mixture is taken and evaluated by:
2. Microscopic Counting if particles are different in shape.
3. Analytical techniques for the drug and other components in the mixture
4. Screen analysis of the mixture, if the powder mixture is different in size.

V- Type mixer:

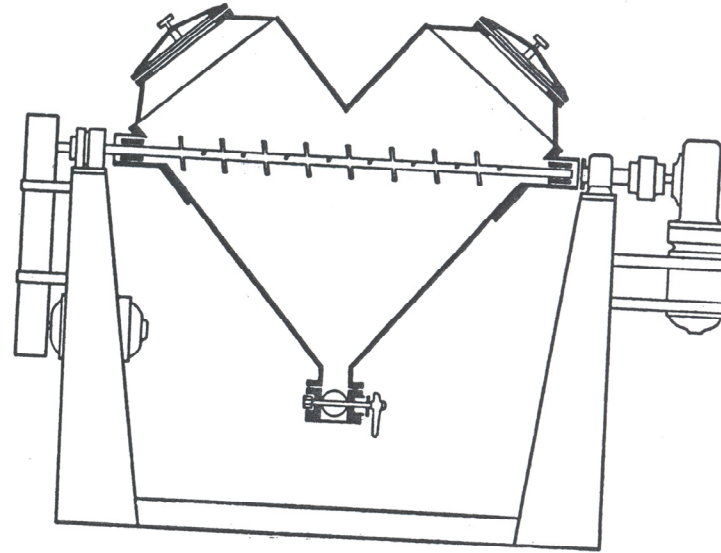

It has two motors :One for rotating the shell and the other for rotating the baffled shaft in opposite direction.

Advantages of the V-type mixer:

1. It is efficient in mixing
2. It has no dead spot
3. It has variable speed rotation
4. Easily cleaned

- 
- ❑ **Mixing**
 - ❑ Definition and objectives
 - ❑ Mixing equipment
 - ❑ Impellers for liquids
 - ❑ Mixers of dry powders
 - Factors affecting mixing of solids
 - 1. Tumbling mixers
 - 2. Agitator mixers
 - 3. Special mixers for powders
 - 4. Entolator impact when mixer
 - 5. Pneumatic mixer
 - 6. V-type mixer
 - ❑ **Mixers for semisolids**
 - Types of flow in semisolids
 - 1. Beaters
 - 2. Kneaders
 - 3. Mixer-Extruders

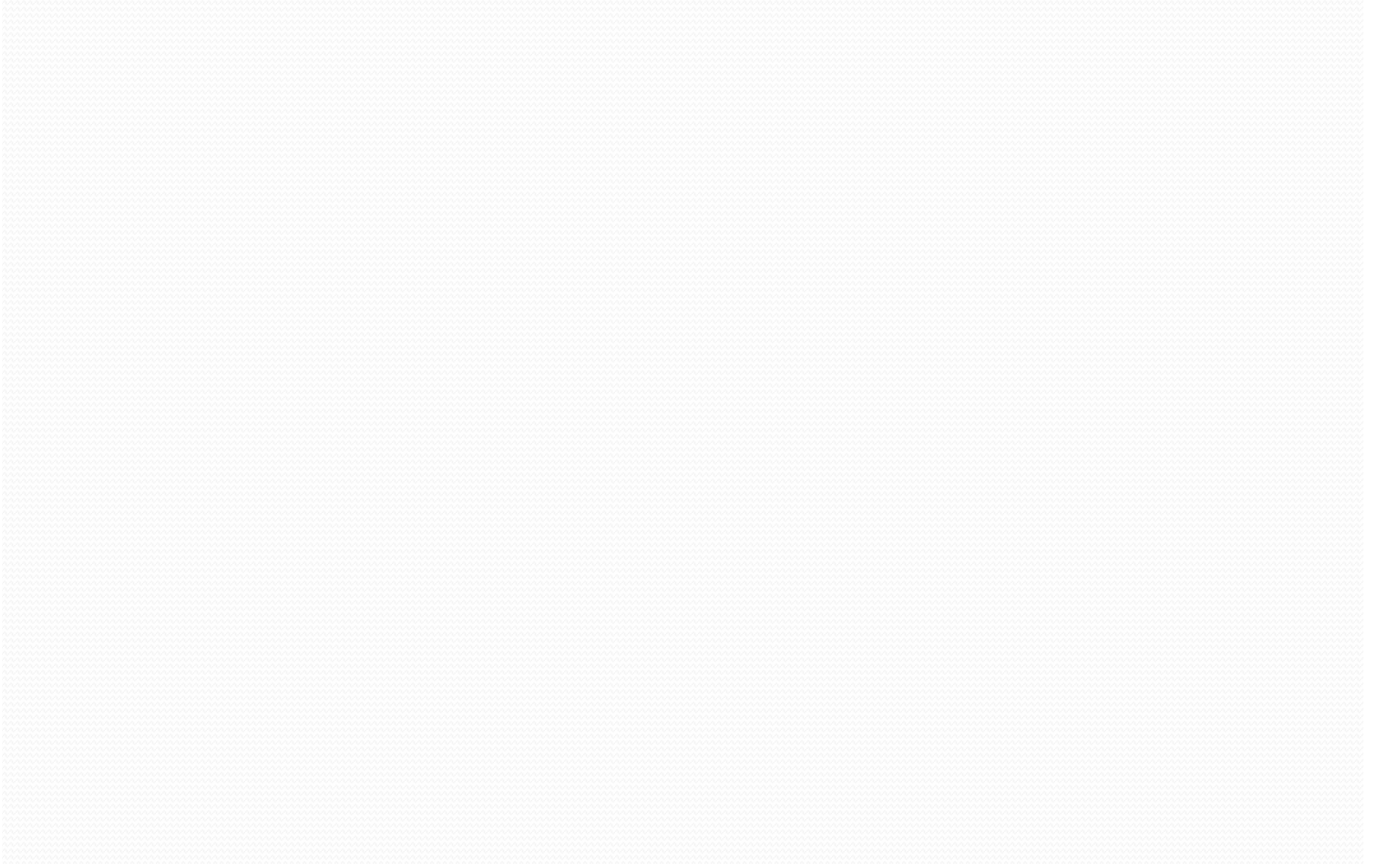
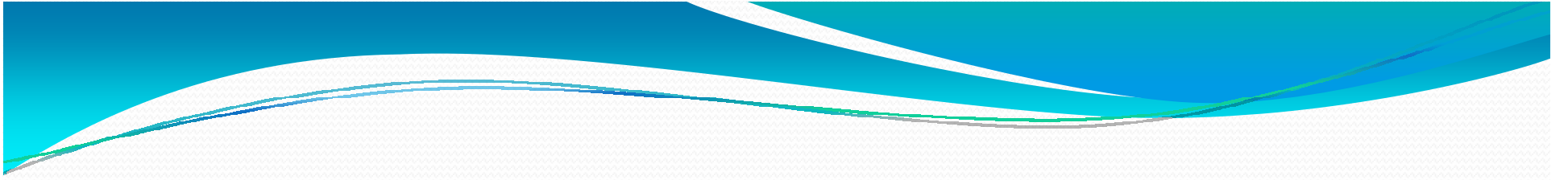

III. Mixers of pastes and plastic masses (semi - solids)

The equipment are similar to liquid mixers but heavy built so shearing action is distributed to all parts of apparatus.

Types of flow in semisolids:

Materials are classified according to the type of flow into:

1- Newtonian flow:

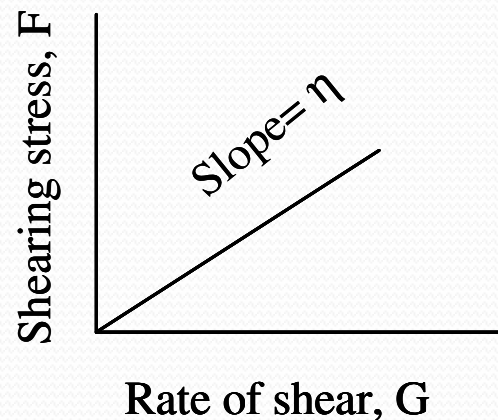

2- Non-Newtonian Flow:

Plastic

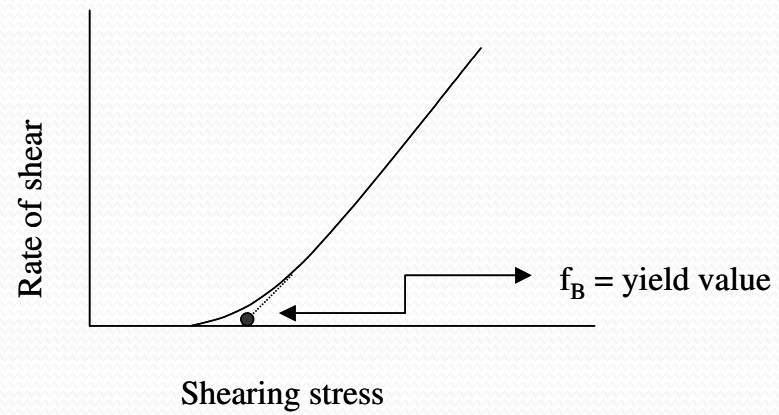

pseudo-plastic

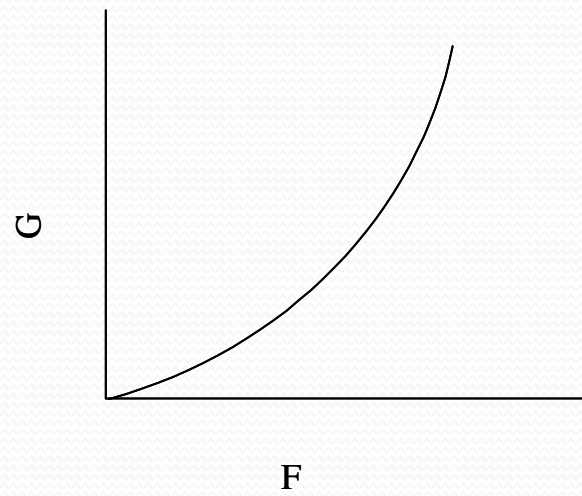

c) Dilatant:

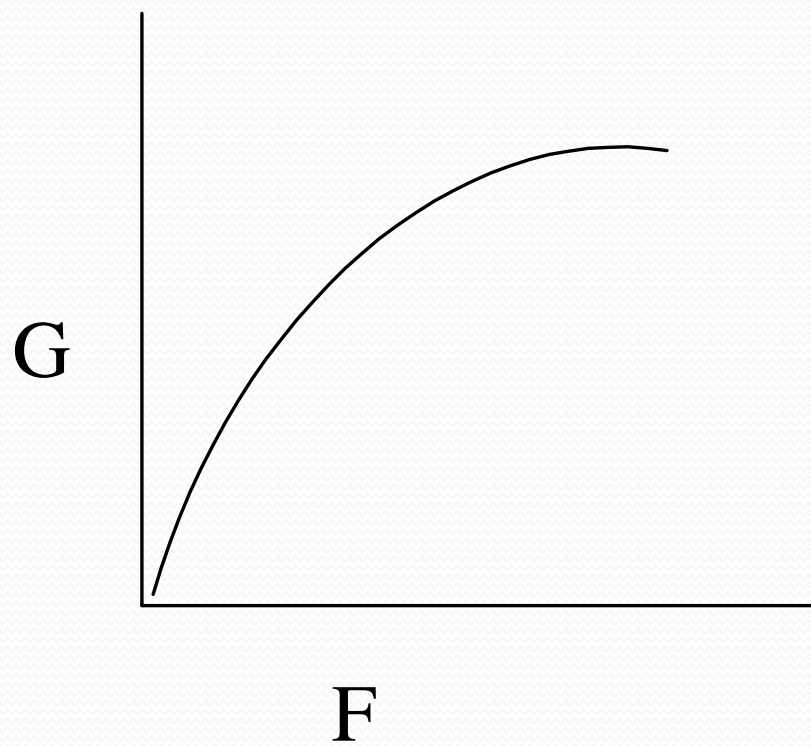



d) Thixotropic systems :



Types of mixers for semisolids and pasts: There are four classes of equipment:

- (1) Beaters (2) Kneaders
- (3) Mixer extruders (4) Mixing rolls.

1. Beaters:

These are similar in principle to the agitator mixers for powders and liquids, but are more heavily built to handle materials of greater consistency. The agitator arms are designed to give a pulling and kneading action, and the shape and the movement of these arms are such that there are no "dead spots" in the mixing vessel. An example of such mixers is the Hobart's Mixer shown in the following Figure

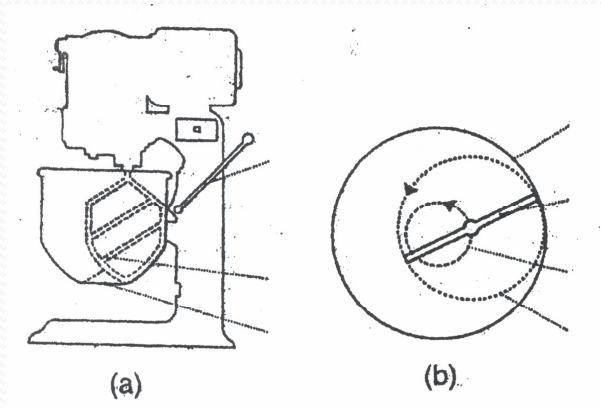

Hobart's Mixer: (a) The mixer (b) Planetary motion.

2. Kneaders:

Kneading involves squashing the material flat, folding it over on itself, and squashing it once more. Most kneading machines also tear the mass of material apart and shear it between a moving arm and a stationary surface.

Double-Arm Mixer

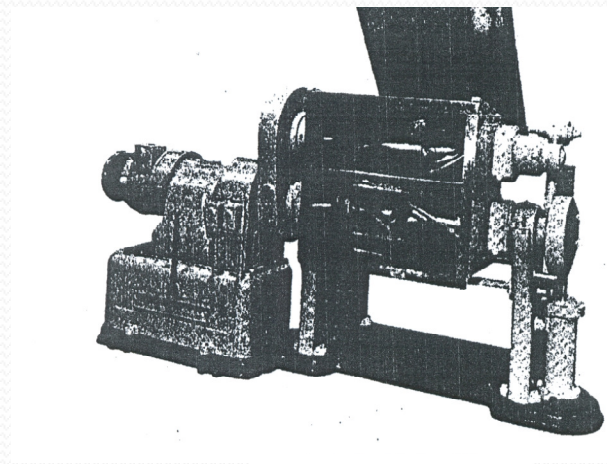

Blades of various designs as those shown in the following Figure are available for several kneading purposes:

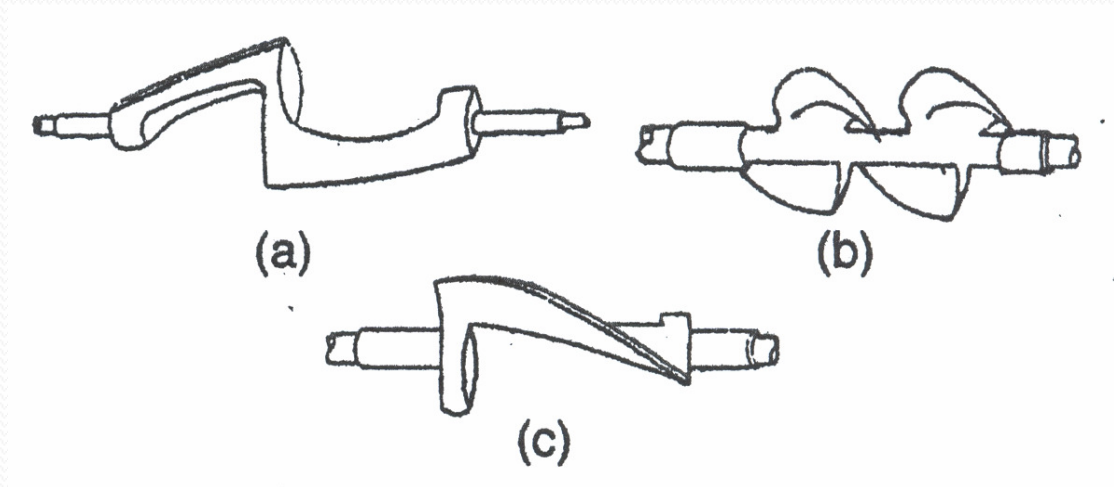

Blades of Various Designs: (a) Sigma blade (b) double-naben blade, (c) Dispersion Blade.

3- Mixer-Extruders:

The operation of a mixer-extruder depends essentially upon cutting and folding the material in a mixing chamber by means of special blades, and extruding it through a die, thereby subjecting the material to additional shear. Mixer-extruders continuously mix materials that are difficult to mix such as clays and thermoplastics.

An example of such mixers is the "Roto-feed Mixer" shown in the following figure.

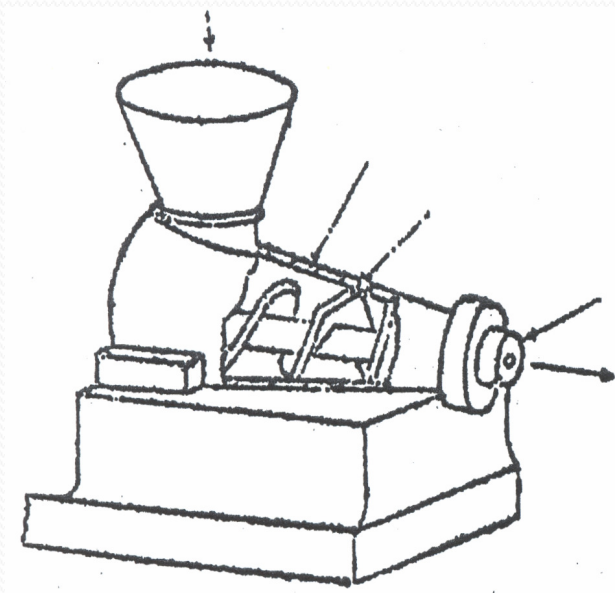

Roto-feed mixer

4. The Mixing Rolls:

In mixing rolls, the materials subjected to intense shear by passing between smooth metal rolls turning at different speeds. By repeated passage between such rolls, solid additives can be thoroughly distributed into pasty or plastic materials.

An example of such mixing rolls is the "*Triple-Roll Mill*".

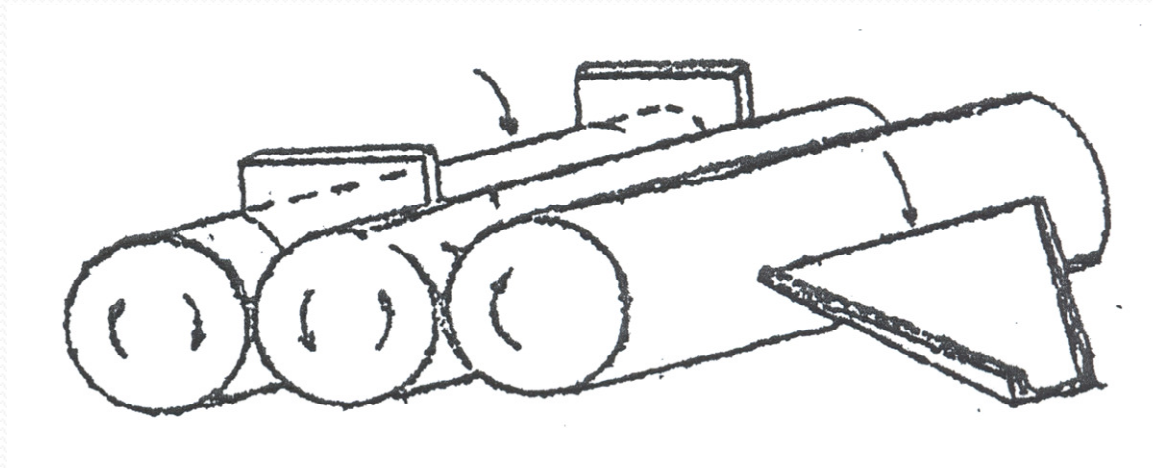

Outline of the lecture:

- ❑ **Mixing**
- ❑ Definition and objectives
- ❑ Mixing equipment
- ❑ Impellers for liquids
- ❑ Mixers of dry powders
 - Factors affecting mixing of solids
 1. Tumbling mixers
 2. Agitator mixers
 3. Special mixers for powders
 4. Entolator impact when mixer
 5. Pneumatic mixer
 6. V-type mixer
- ❑ Mixers for semisolids
 - Types of flow in semisolids
 1. Beaters
 2. Kneaders
 3. Mixer-Extruders