

Republic of Iraq
Ministry of Higher Education
and Scientific Research
Al-Mustaqbal University College
Computer Engineering Techniques Department



Subject: Digital Signal Processing

Third Class

Lecture One

By

MSc. Sarah Abbas



Digital Signal Processing (DSP)

Introduction:

DSP is the mathematics, the algorithms, and the techniques used to manipulate these signals after they have been converted into a digital form. This includes a wide variety of goals, such as: enhancement of visual images, recognition and generation of speech, compression of data for storage and transmission, etc.

Most signals in nature are analog such as voltage, temperature, pressure, ECG, speech signals, ...etc. Usually a transducer (sensor) is used to convert the non-electrical signal to the analog electrical signal (voltage).

In its most general form, a DSP system consists of three main components, as illustrated in Fig.1.

- The analog-to-digital (A/D) converter transforms the analog signal $x(t)$ at the system input into a digital signal $x[n]$. An A/D converter can be thought of as consisting of a sampler (creating a discrete-time signal), followed by a quantizer (creating discrete levels).
- The digital system performs the desired operations on the digital signal $x[n]$ and produces a corresponding output $y[n]$ also in digital form.
- The digital-to-analog (D/A) converter transforms the digital output $y[n]$ into an analog signal $y(t)$ suitable for interfacing with the outside world.

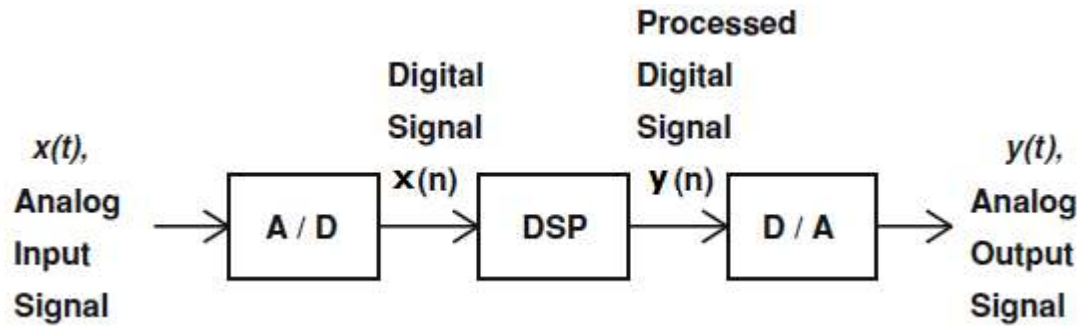

Fig. 1. Block diagram of a generic signal processing system.

Digital Signal Processing Versus Analog Signal Processing

DSP has a number of advantages over analog signal processing (ASP), namely:

Advantages:-

- 1- More flexible.
- 2- Often easier system upgrade.
- 3- Data easily stored in memory.
- 4- Better control over accuracy requirements.
- 5- Reproducibility.
- 6- Linear phase
- 7- No drift with time and temperature
- 8- DSP is less susceptible to noise and power supply disturbances than ASP.

Limitations:

- 1- A/D & signal processors speed: wide-band signals still difficult to treat (real-time systems).
- 2- Finite word-length effect.
- 3- Cost/complexity added by A/D and D/A conversion.



DSP Applications:

The figure below shows the DSP applications. Many more areas are increasingly being explored by engineers and scientists. Applications of DSP techniques will continue to have profound impacts and improve our lives.

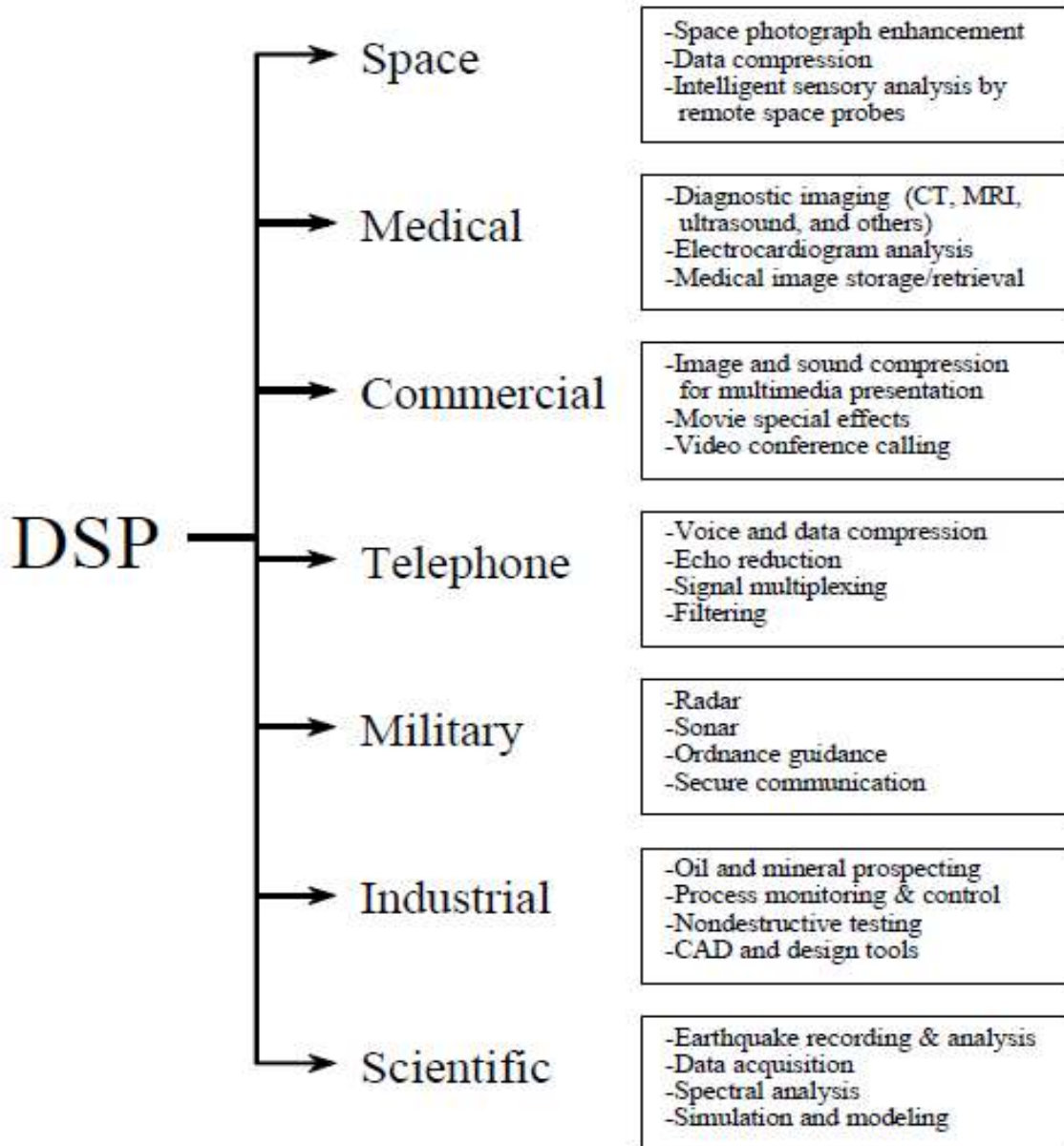

Fig 3 : The DSP Applications.