

Radiation Physics

Hussein Ali Madlool

Radiology Techniques Department

2nd Class

Al-Mustaqbal University college

Lecture 8: The X-Ray Tube

Part 2

2020/2021

Focal spot

The focal spot is the area of the target from which x-rays are emitted.

The effective target area, or effective focal spot size, is the area projected onto the patient and the image receptor

- When the target angle is made smaller, the effective focal spot size also is made smaller.
- Diagnostic x-ray tubes have target angles that vary from approximately 5 to 20 degrees

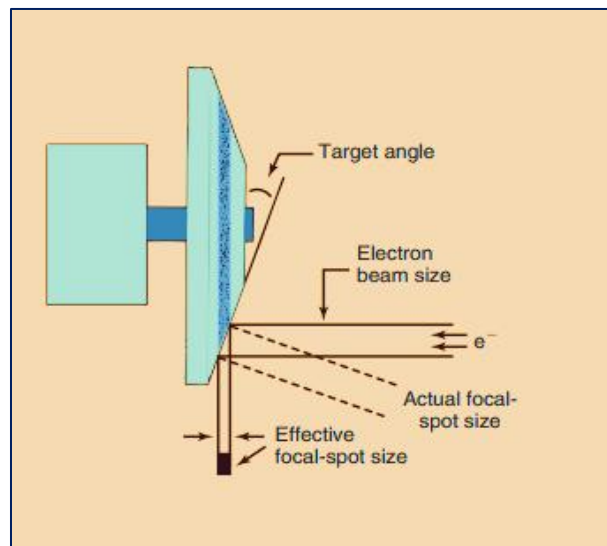
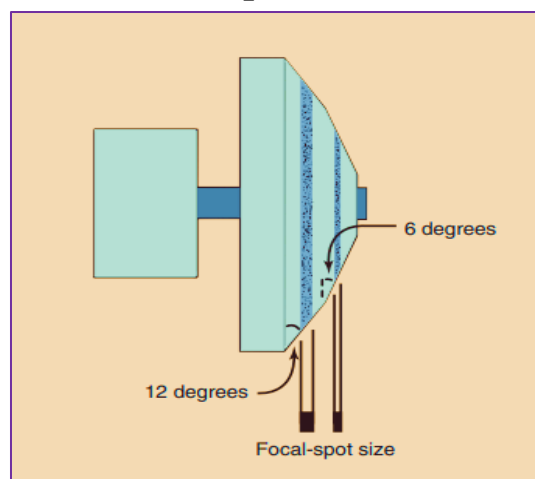

Figure 1: The line-focus principle allows high anode heating with small effective focal spots. As the target angle decreases, so does the effective focal spot size.



Some targets have two angles to produce two focal spots. To achieve this, the filaments must be placed one above the other.

The effective focal spot depends on

1. Actual focal spot size
2. Target angle

The heel effect

Describe as varying radiation intensity across the x-ray field in the anode–cathode direction caused by attenuation of x-rays in the heel of the anode.

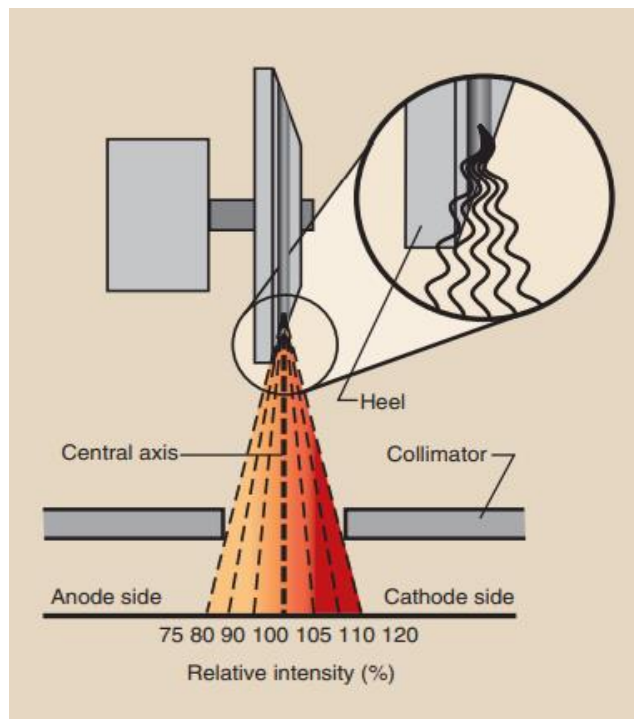

Figure 2: The heel effect results in reduced x-ray intensity on the anode side of the useful beam caused by absorption in the “heel” of the target

(The reason) the intensity of x-rays that are emitted through the “heel” of the target is reduced because they have a longer path through the target and therefore increased absorption. This is the heel effect.

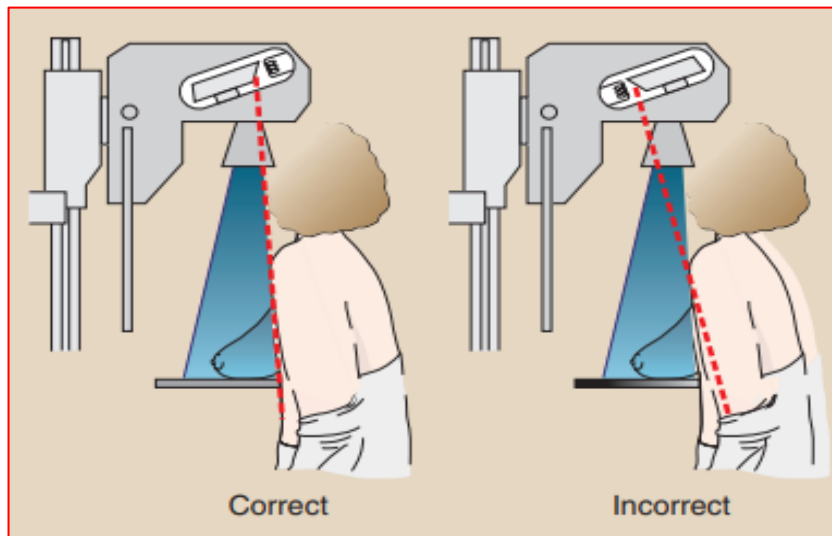

Figure 3: The heel effect can be used to advantage in mammography by positioning the cathode toward the chest wall to produce a more uniform optical density.

Protective X-ray Tube Housing

Every x-ray tube must be contained within protective housing that reduces leakage radiation during use.

- **Leakage radiation** is that radiation emitted from the x-ray tube housing in all directions other than that of the useful beam
- Leakage radiation must be less than 100 mR/hr (1 mGya/hr) at a distance of 1 m from the protective housing.

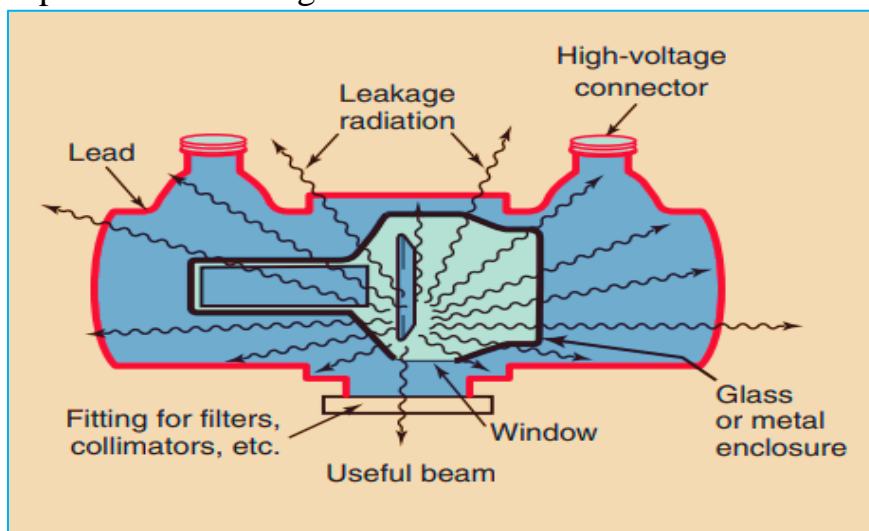

Figure : Protective housing reduces the intensity of leakage radiation to less than 1 mGya/hr at 1 m.

Off-Focus Radiation

Some of the electrons bounce off the focal spot and then land on other areas of the target (see figure 5), causing x-rays to be produced from outside of the focal spot

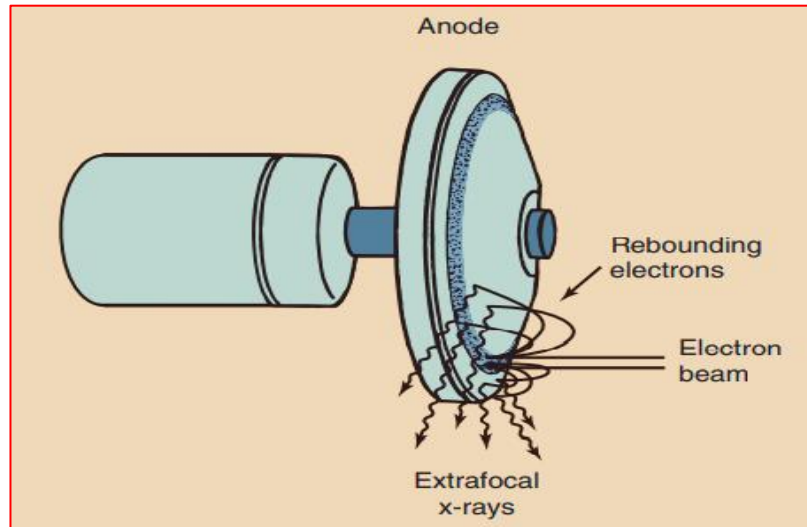

Figure 4: Extrafocal x-rays result from interaction of electrons with the anode off of the focal spot.

off-focus radiation can image patient tissue that was intended to be excluded by the variable-aperture collimators.

- Off-focus radiation is reduced by designing a fixed diaphragm in the tube housing near the window of the x-ray tube (Figure 5). This is a geometric solution.

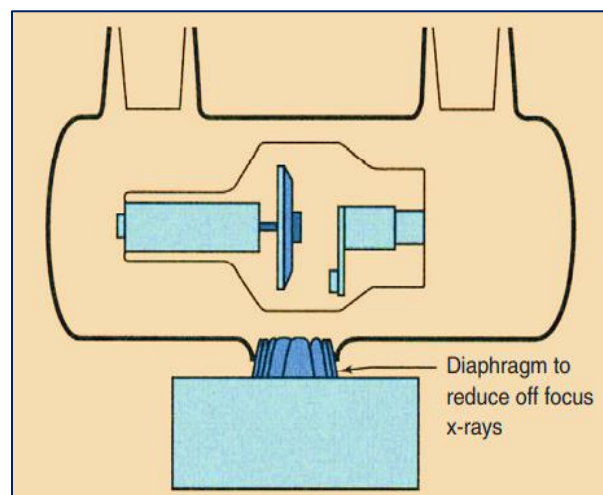

Figure 5



Figure 6: Off-Focus radiation effect