



Solar Thermal Technology

Contents



- Introduction
- Technology Overview
- Solar thermal system type
- Heat storage systems



INTRODUCTION

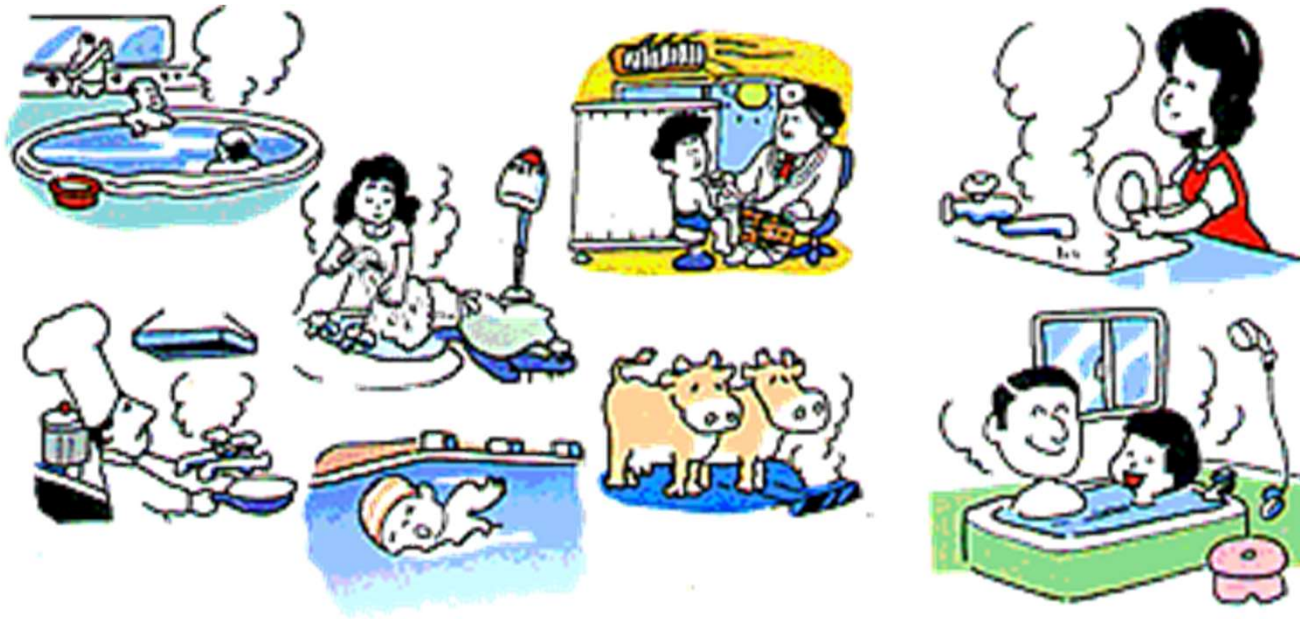

- Domestic Water Heating
- Pool and Spa Heating
- Process Water Heating
- Air Conditioning "Reheat"



Examples of Cost-Effective Solar Thermal Applications



● Low temperature:

- Swimming Pools
- Hatchery Ponds (برك التفريخ)
- Ventilation Preheat (
- Car Wash
- Snow Melting

● High temperature:

- Industrial Processes
- Electrical Generation
- Often Used for Water and Space Heating

● Mid temperature:

- Residential and Commercial Hot Water
- Cafeterias
- Laundries
- Space Heating (Radiant Slab)
- Prisons
- Recreational Facilities (المرافق الترفيهية)
- Day Care

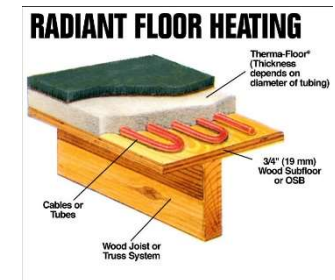

System Types

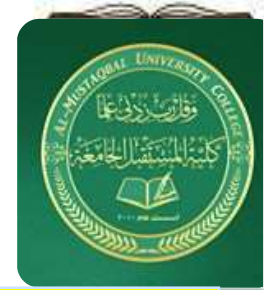

الانظمة التي تعتمد على مصادر
الطاقة الطبيعية المتوافرة

- Passive Systems
 - Thermosyphon
 - Integral Collector Storage

الأنظمة التي تعتمد على مصادر الطاقة غير
الطبيعية

- Active Systems
 - Open Loop:
 - Direct
 - Drain Down
 - Closed Loop:
 - Drain Back
 - Antifreeze



Passive, Thermosyphon, Direct System



A Thermosiphon system is heat carried by water or transfer fluid and use natural convection to transport it from the collector to storage

يعتمد نظام ثرموسيفون على فرق الكثافة بين الماء الساخن والماء البارد الذي يؤدي إلى هبوط الماء البارد (الأثقل وزنا) إلى الأسفل وصعود الماء الساخن (الأخف وزنا إلى الأعلى) . ولذلك يجب وضع جهاز جمع الطاقة الشمسية (solar collector) في مستوى أخفض من مستوى خزان المياه (water tank) وبذلك تنتقل المياه من الخزان إلى جهاز جمع الطاقة الشمسية عبر انبوب هابط يصل بينهما . وعندما تسخن المياه في جهاز جمع الطاقة تعود وتنتقل إلى خزان المياه عن طريق انبوب صاعد يربط بينهما يصل هذا الأنبوب الجزء العلوي لجهاز جمع الطاقة بالنصف العلوي للخزان.

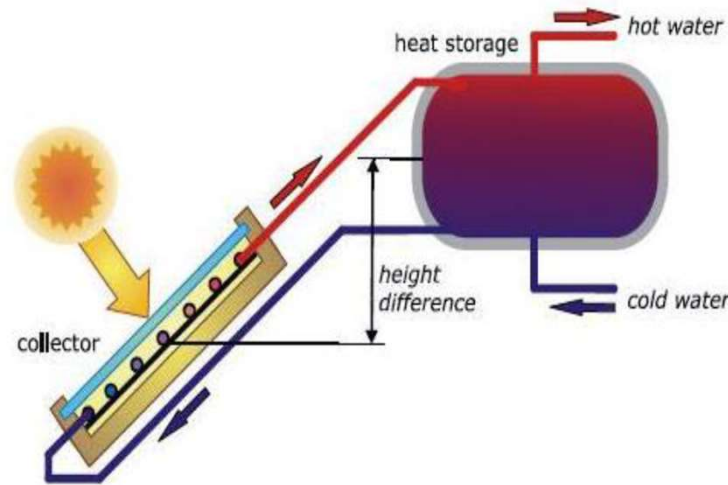

Passive, Thermosyphon, Direct System



A Thermosiphon system is heat carried by water or transfer fluid and use natural convection to transport it from the collector to storage

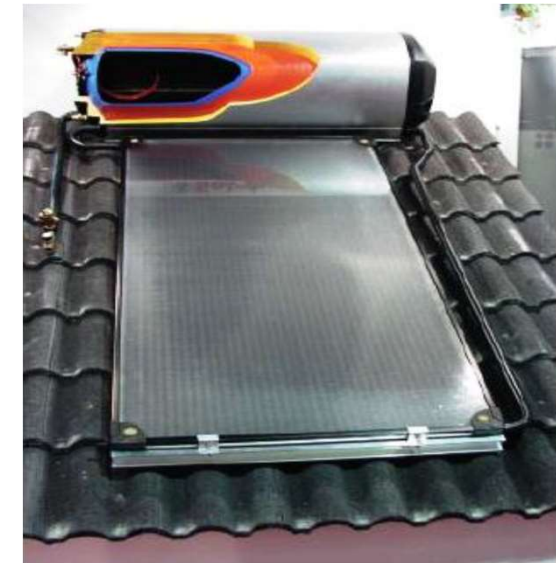
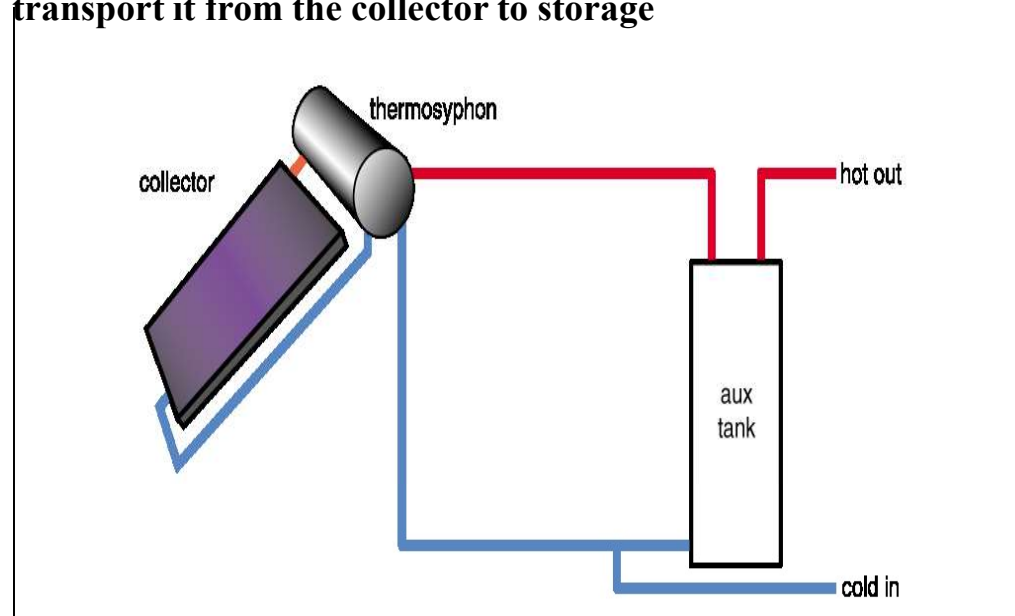

- Auxiliary element can also be in tank above collector, eliminating the auxiliary tank altogether. يمكن استخدام هيتتر اضافي في داخل الخزان لامكانية عمله اثناء غياب الشمس او في وقت الليل

- No freeze protection لا يحتوي على اجهزة منع التجمد لذلك لا يصلح استخدامه في المناطق شديدة البرودة

- Minimal hard water tolerance (اقل تحمل للمياه الصلده او المتثلجة)

- Low maintenance requirements صيانة اقل



Passive, Thermosyphon, Direct System



الايجابيات :

- 1- غير ملوث (صديق للبيئة) 2-توفير للطاقة -يعتمد على المصادر الطبيعية المتجددة
- 3- تكلفة أقل 4-لا يحتل حيز داخل المبنى(يوفر مساحة)

السلبيات :

- 1-تعرض خزان المياه للإشعاع الشمسي بشكل مستمر قد يؤدي إلى التأثير على تركيب مادته 2-تتأثر فعالية هذا النظام بالموقع الجغرافي المستخدم فيه 3-يأثر على المنظر الخارجي للمبنى-الناحية الجمالية للتصميم 4-يحتاج لنظام انشائي متين ليستطيع تحمل وزن خزان الماء 5-لا يصلح استخدامه في المناطق شديدة البرودة 6-يجب اختيار موقعه بحيث نضمن تعرضه لأكبر قدر من الإشعاع الشمسي (مثل الواجهة الجنوبية .)



Passive, Integral Collector Storage (ICS) Direct System

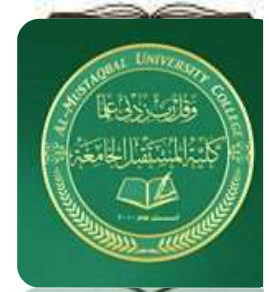

Integral Collector Storage systems, also known as **ICS**, “batch” or “bread box” water heating systems, are very similar in design and operation to the flat plate panel collector.



The main advantage of an “integral collector storage” system is that they do not need controls, pumps, sensors, or any other mechanical or moving parts, so maintenance requirements are minimal.



Passive, Integral Collector Storage (ICS) Direct System

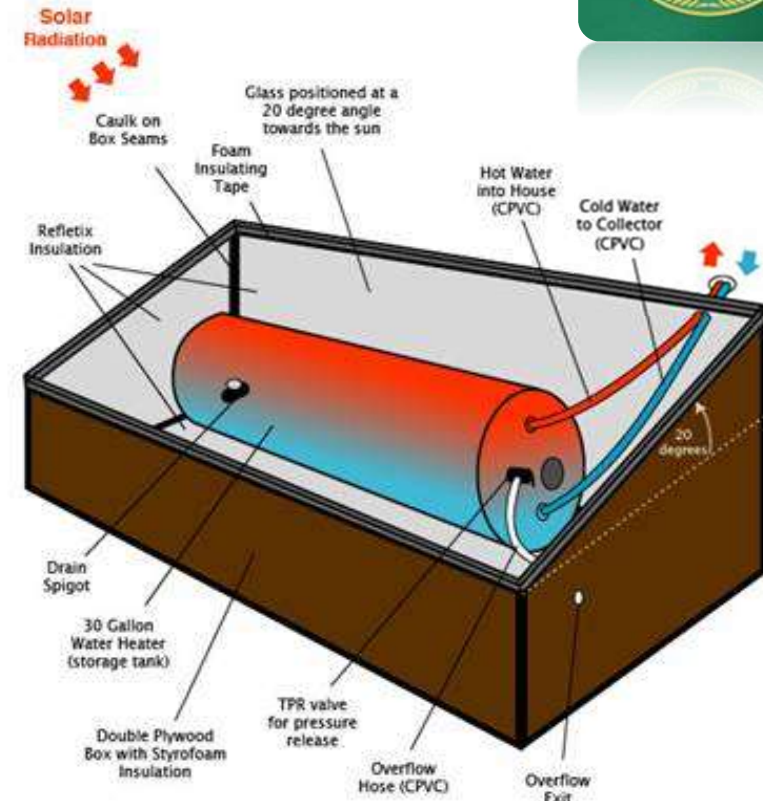
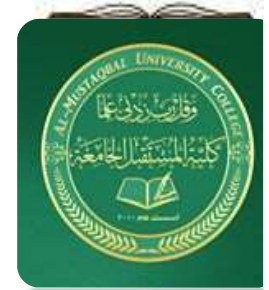

- Moderate freeze protection (حماية معتدلة من التجمد)
- Minimal hard water tolerance
- Very low maintenance requirements



Active, Open-loop, Pumped Direct System



Five types of systems belong in this category: **direct circulation systems, indirect water heating systems, air systems, heat pump systems, and pool heating systems.**

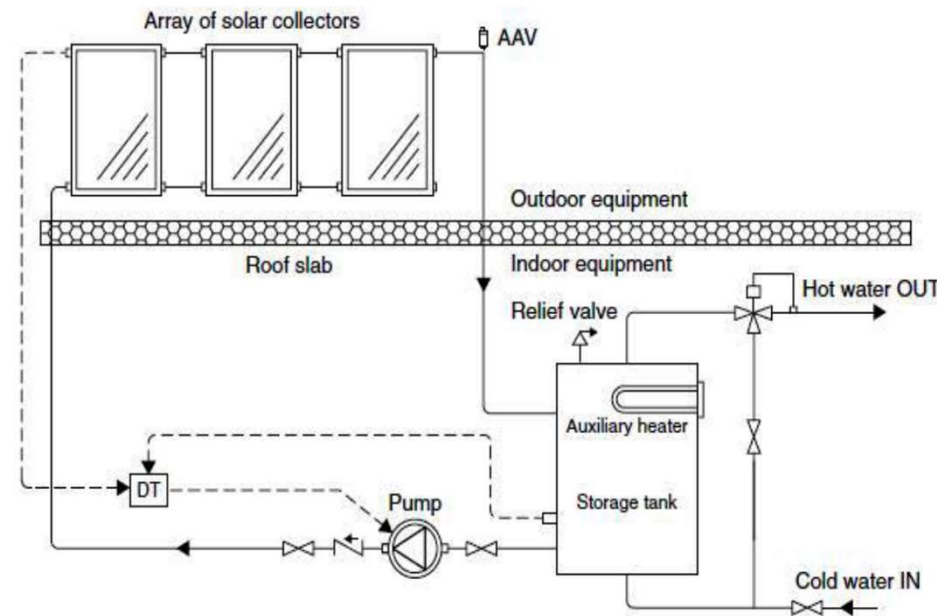
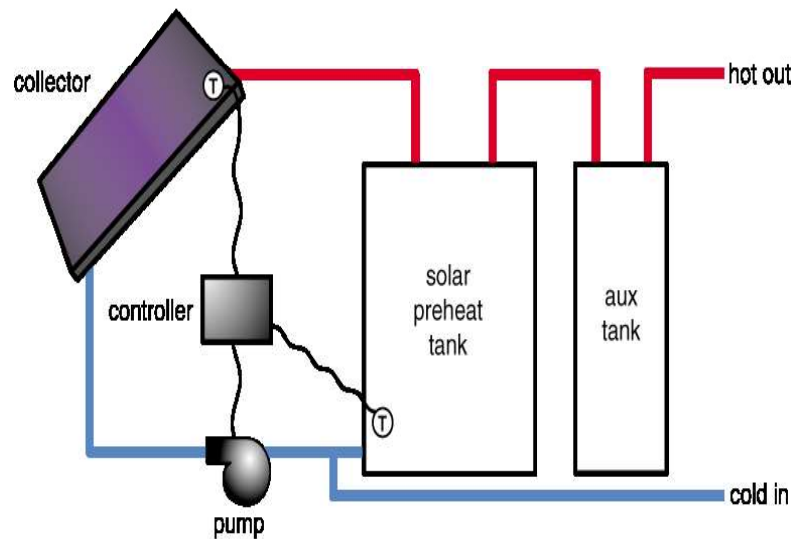

- No freeze protection
- Minimal hard water tolerance اقل تحمل للمياه الصلده او المتلجة
- High maintenance requirements



Active, Closed-loop (antifreeze), Indirect System

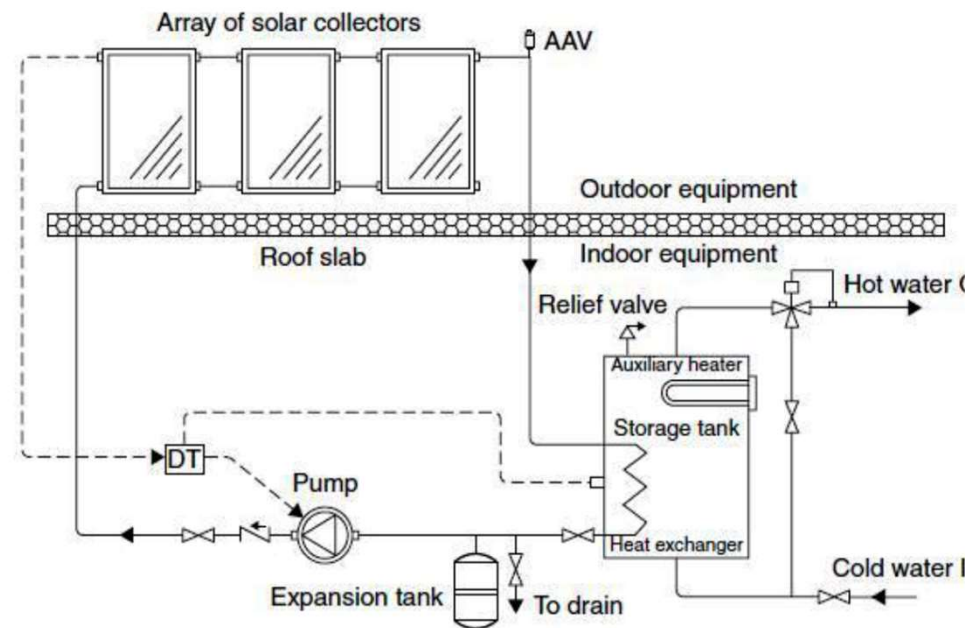
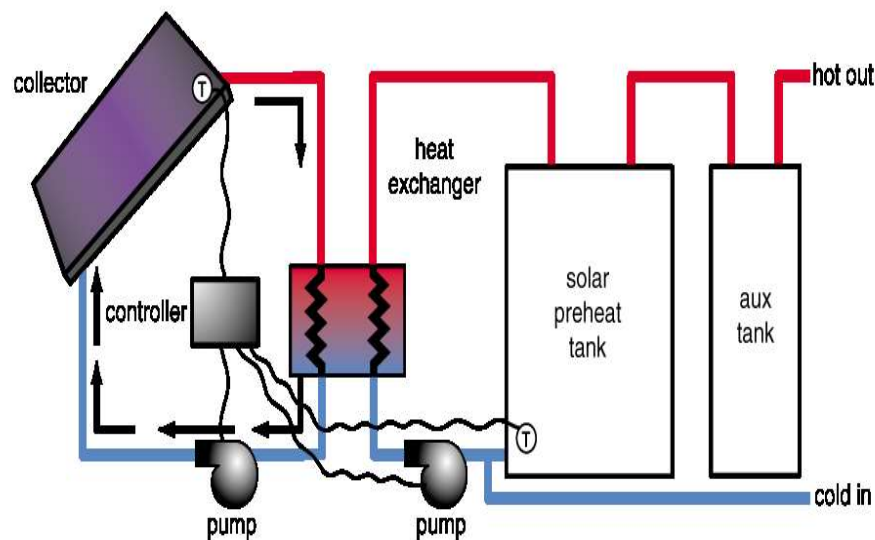

- Excellent freeze protection
- Good hard water tolerance
- High maintenance requirements



Active, Closed-loop, Drainback, Indirect System

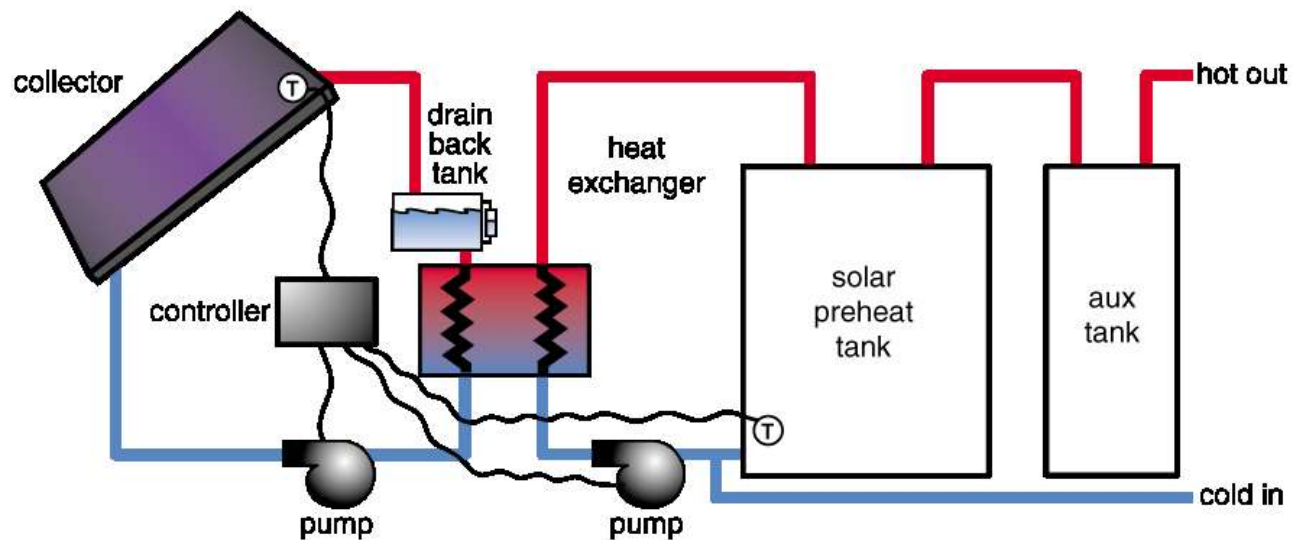

- Good freeze protection
- Good hard water tolerance
- High maintenance requirements



Tempering Valve to Prevent Scalding(Thermostatic :



يستخدم لغرض على الحفاظ على درجات حرارة الماء ثابتة حيث يعمل على اضافة الماء البارد الى الماء الساخن جدا للمحافظة على مستوى معتدل من الماء الخارج للمستخدم

Extremely
Important for
Safety!

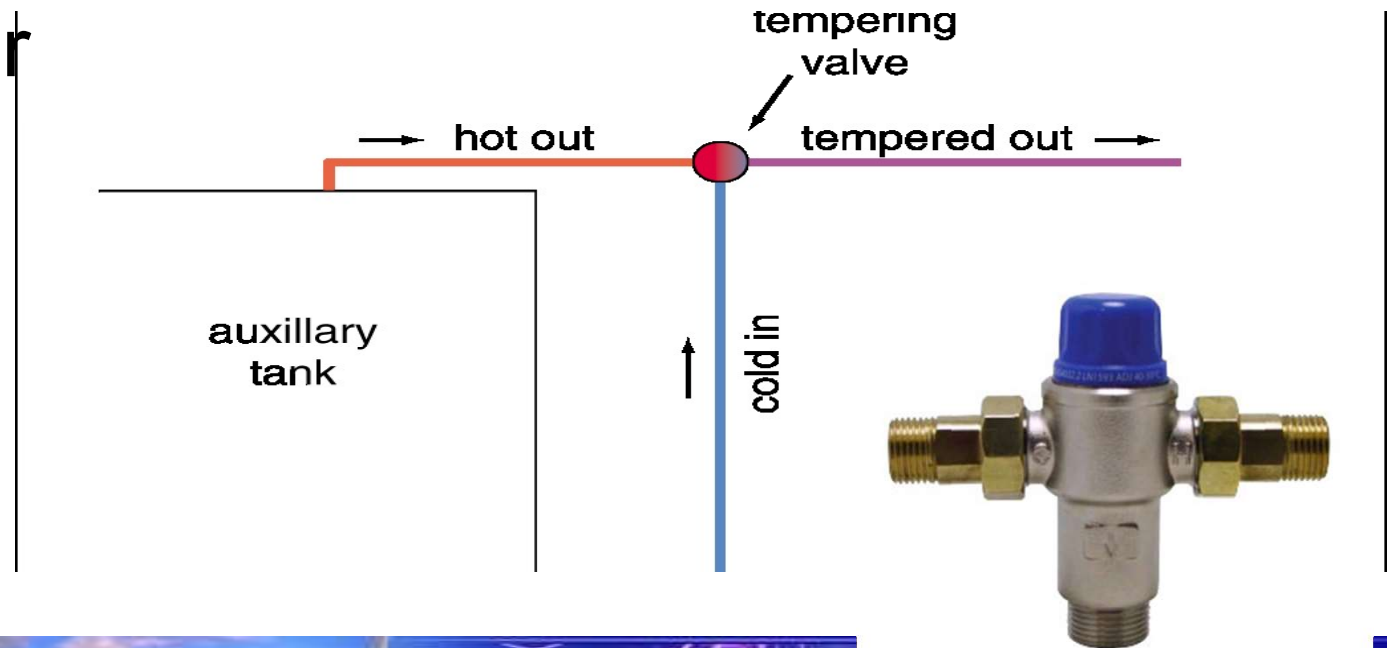

Air water-Heating Systems



The advantages of this system are that air does not need to be protected from freezing or boiling, is non-corrosive, does not suffer from heat transfer fluid degradation, and is free. Additionally, the system is more cost effective because no safety valves or expansion vessels are required.

The disadvantages are that airhandling equipment (ducts and fans) needs more space than piping and pumps, air leaks are difficult to detect, and parasitic power consumption (electricity used to drive the fans) is generally higher than that of liquid systems

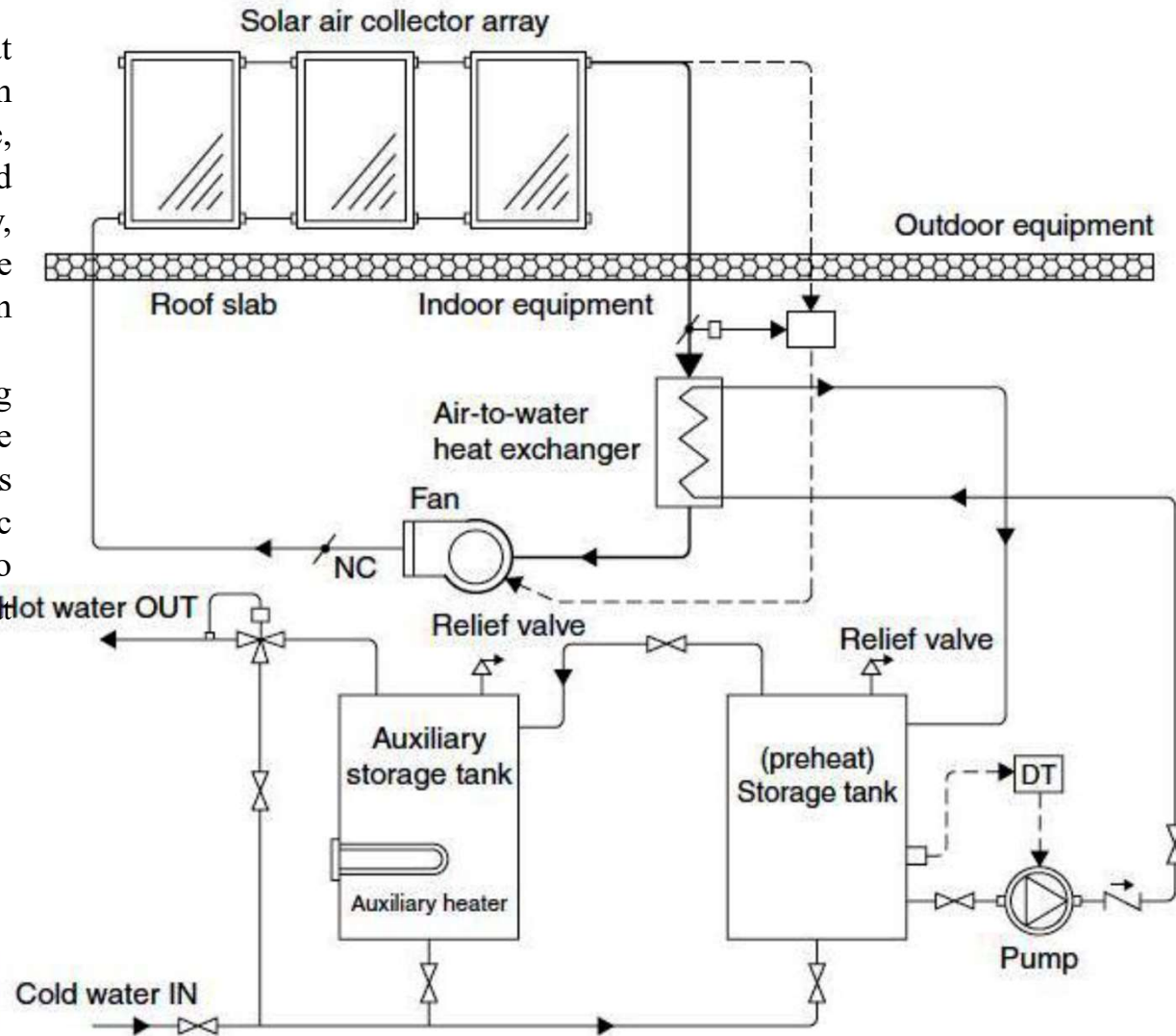

Pool Heating Systems

أنظمة تدفئة حمامات السباحة



Solar Pool Heating

- Perhaps the most cost effective application of solar energy
 - Simple system (no storage tank)
 - High efficiency (low critical level)
 - Load coincident with solar radiation
 - Significant energy required

اهم الميزات :

1- بساطة التصميم

2- كفاءة عالية

3- الحمل متزامن او مستقر من الاشعاع الشمسي

4- متطلبات طاقة مناسبة للتسخين

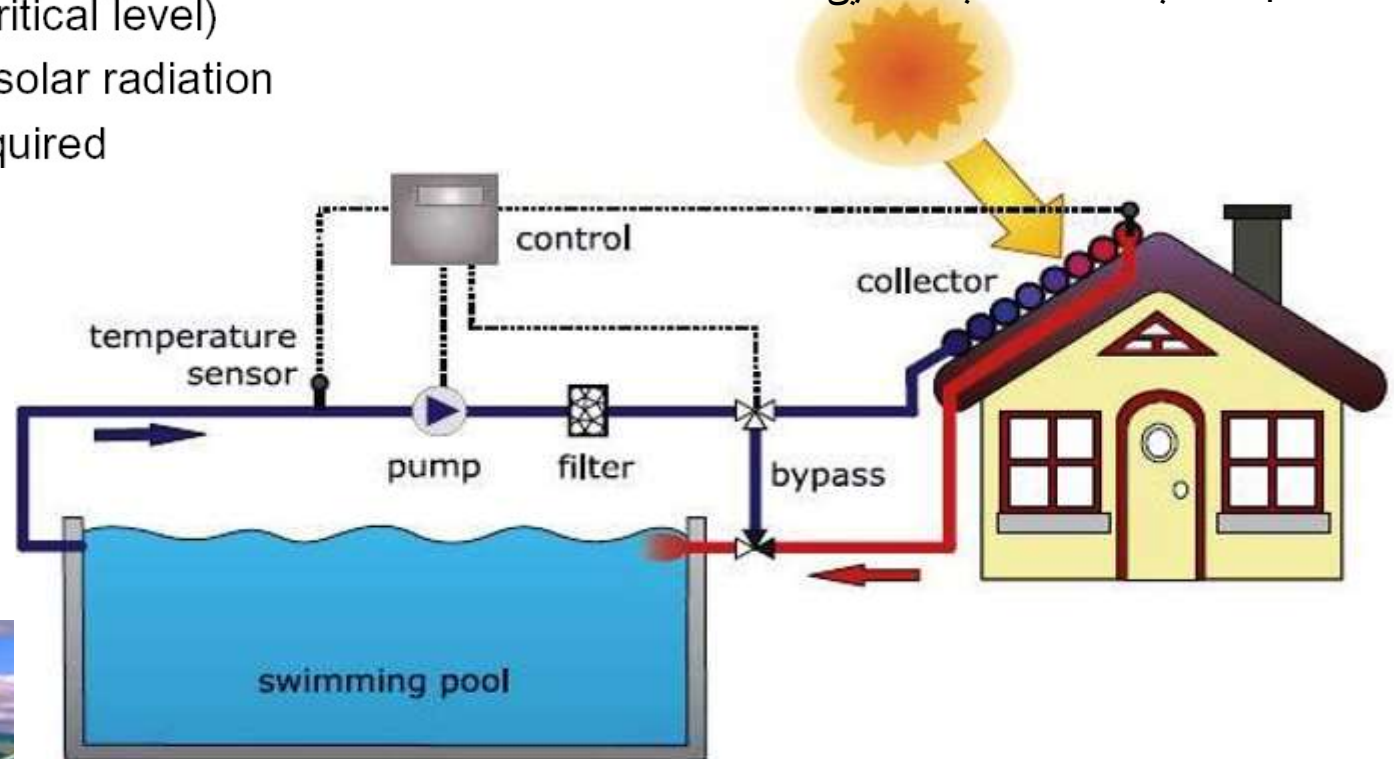

Heat storage systems



Energy storage is accomplished by devices or physical media that store energy to perform useful processes at a later time.

تخزين الطاقة هو عملية التقاط الطاقة المنتجة في وقت واحد للاستخدام في وقت لاحق لغرض الاستفادة منها في تنفيذ عمليات مفيدة كما التسخين او التبريد او توليد الطاقة الكهربائية او اي شي اخر.

A device that stores energy is generally called an accumulator or battery .

يطلق على الاجهزة التي تخزن الطاقة بالمخزانات التراكيمية مثل البطاريات والمخزانات الحرارية او الكيماوية .



Photo Credit: NRCan

Heat Storage Systems



Thermal storage is one of the main parts of a solar heating, cooling, and power generating system. Because for approximately half the year any location is in darkness, heat storage is necessary if the solar system must operate continuously. For some applications, such as swimming pool heating, daytime air heating, and irrigation pumping, intermittent operation is acceptable, but most other uses of solar energy require operating at night and when the sun is hidden behind clouds.

A storage tank in a solar system has several functions, the most important of which are:

1- The solar power is not steady and available all day long. It varies with time, weather, and season.

Therefore , the instability and sudden loss of the solar make high efficiency and long-term solar utilization

difficult. بسبب عدم استقرار الطاقة الشمسية خلال اليوم وتغيرها مع الوقت والشهر والسنة وايضا فقدان اشعة الشمس المفاجى بسبب الغيوم لذلك من الصعب استخدامها مباشرة ولفترات طويلة وبكفاءة عالية

2- Improvement of the utilization of collected solar energy by providing thermal capacitance to alleviate the solar availability and load mismatch and improve the system response to sudden peak loads or loss of solar input. لذلك يتم تعزيز المجمعات الحرارية الشمسية بمنظومات الخزن الحراري لغرض زيادة كفاءتها وامكانية تعزيز المنظومات الحرارية بشكل مستمر اثناء غياب الشمس او فقدان المفاجى لاشعة الشمس

Generally, solar energy can be stored in liquids, solids, or phase-change materials (PCM). بصورة عامة الطاقة الشمسية يمكن تخزينها في السوائل والمواد الصلبة والمواد المتغير بالطور كما الشمع وبعض المواد الكيمياوية الاخرى .



Air System Thermal Storage



The most common storage media for air collectors are rocks. Other possible media include PCM, water, and the inherent building mass. Gravel is widely used as a storage medium because it is abundant and relatively inexpensive.

يستخدم الحصى على نطاق واسع كوسيط للتخزين لأنه متوفر وغير مكلف نسبيًا

خزان حراري يحتوي على الحصى او الرمل او المواد لمتغير الطور لغرض تخزين الطاقة الحرارية

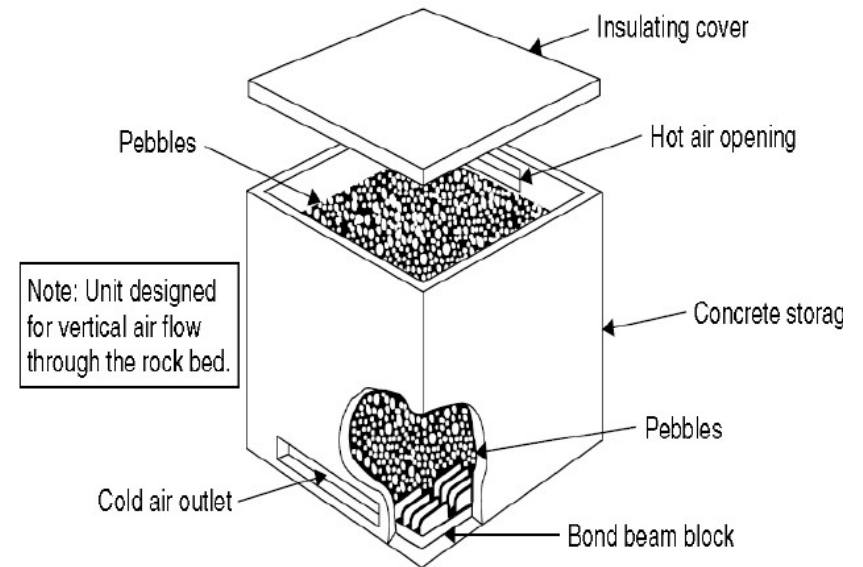
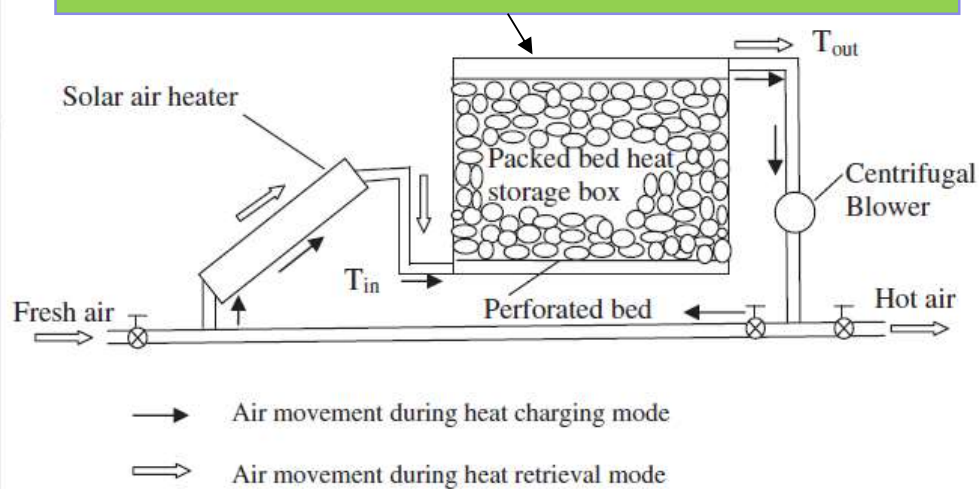

Vertical flow packed rock bed.



Liquid System Thermal Storage



Two types of water storage for liquid systems are available: **pressurized and unpressurized**. Other differentiations include the use of an **external or internal heat exchanger** and **single or multiple tank configurations**. Water may be stored in copper, galvanized metal, or concrete tanks.

Pressurized systems are open to city mains water supply. Pressurized storage is preferred for small service water heating systems

Water is a convenient heat storage medium because it has a high specific heat capacity

Pressurized storage with internal heat exchanger

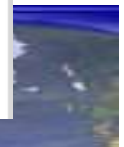
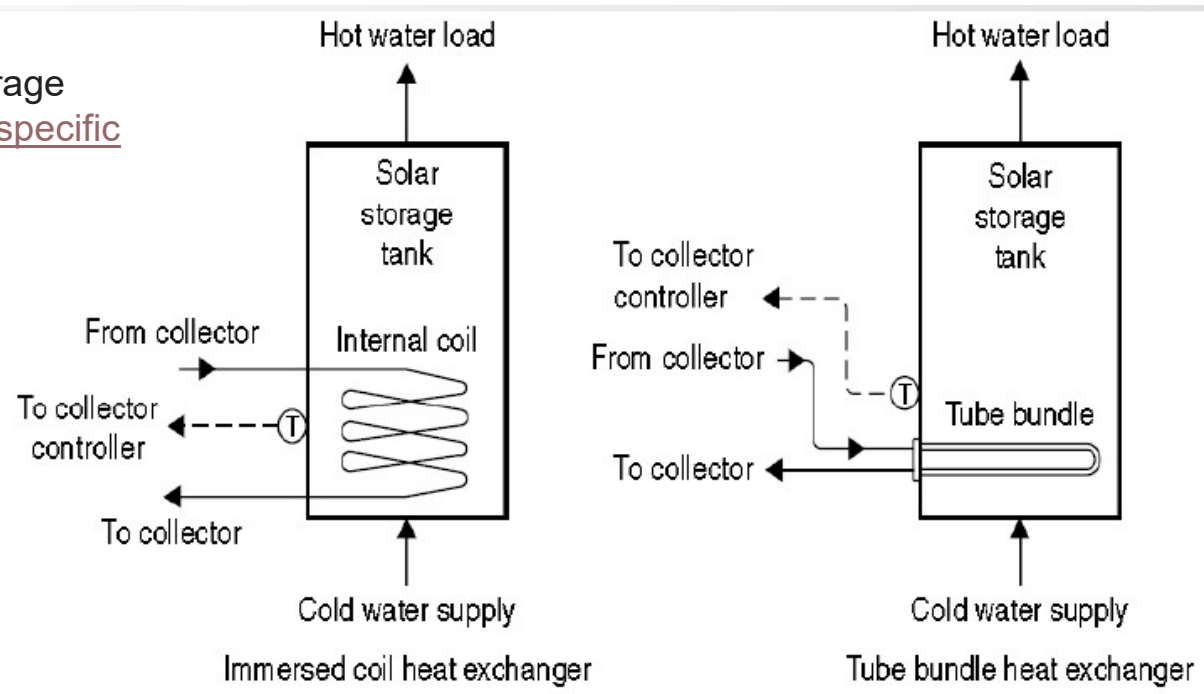

Liquid System Thermal Storage



Sometimes, because of the required storage volume, more than one tank is used instead of one large one, if such a large-capacity tank is not available. Additional tanks offer, in addition to the extra storage volume, increased heat exchanger surface (when a heat exchanger is used in each tank) and reduced pressure drop in the collection loop

Multiple-tank storage arrangements with internal heat exchangers

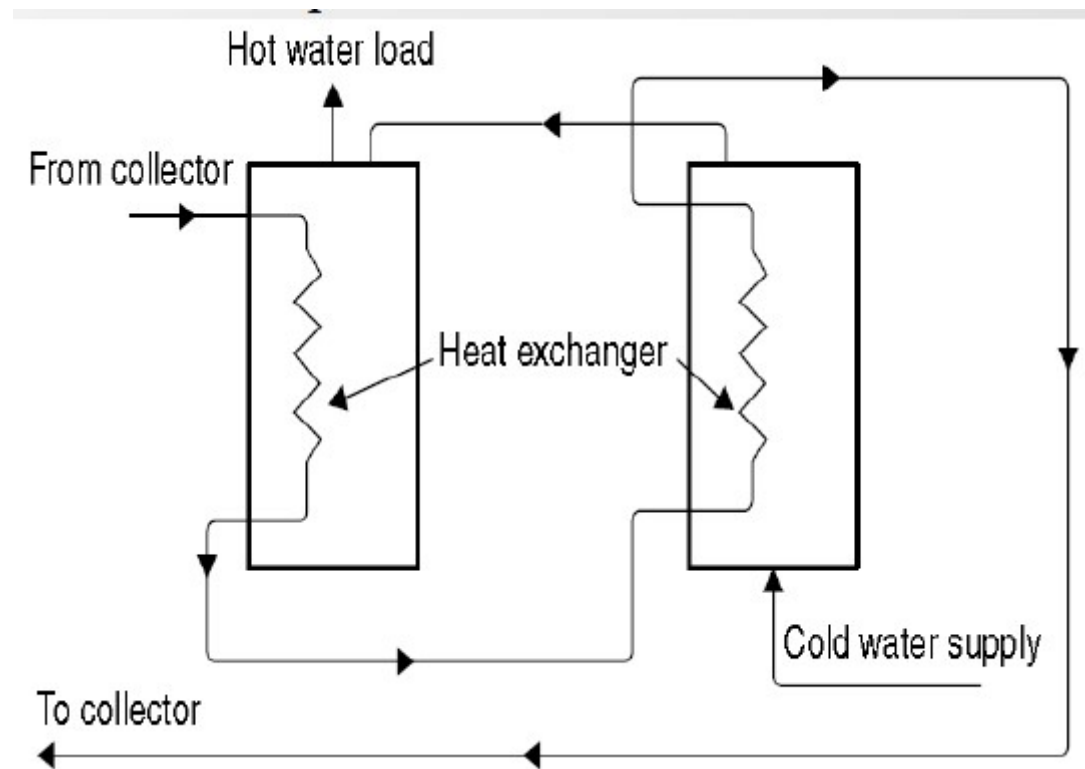

Liquid System Thermal Storage



An external heat exchanger provides greater flexibility because the tank and the exchanger can be selected independently of other equipment (see Figure 4). The disadvantage of this system is the parasitic energy consumption, in the form of electrical energy, that occurs because of the additional pump.

Pressurized storage system with external heat exchanger

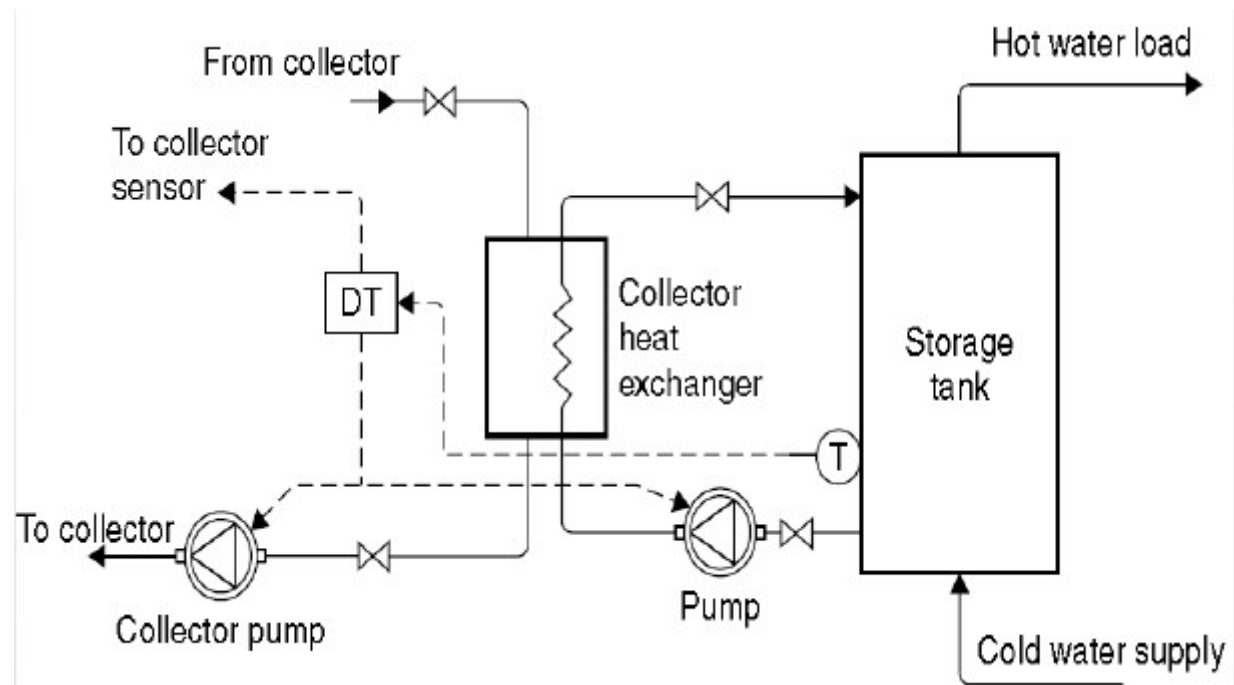

Liquid System Thermal Storage



Unpressurized storage for water and space heating can be combined with the pressurized city water supply. This implies the use of a heat exchanger on the load side of the tank to isolate the high-pressure mains' potable water loop from the low-pressure collector loop. An unpressurized storage system with an external heat exchanger is shown in Figure 9-5.

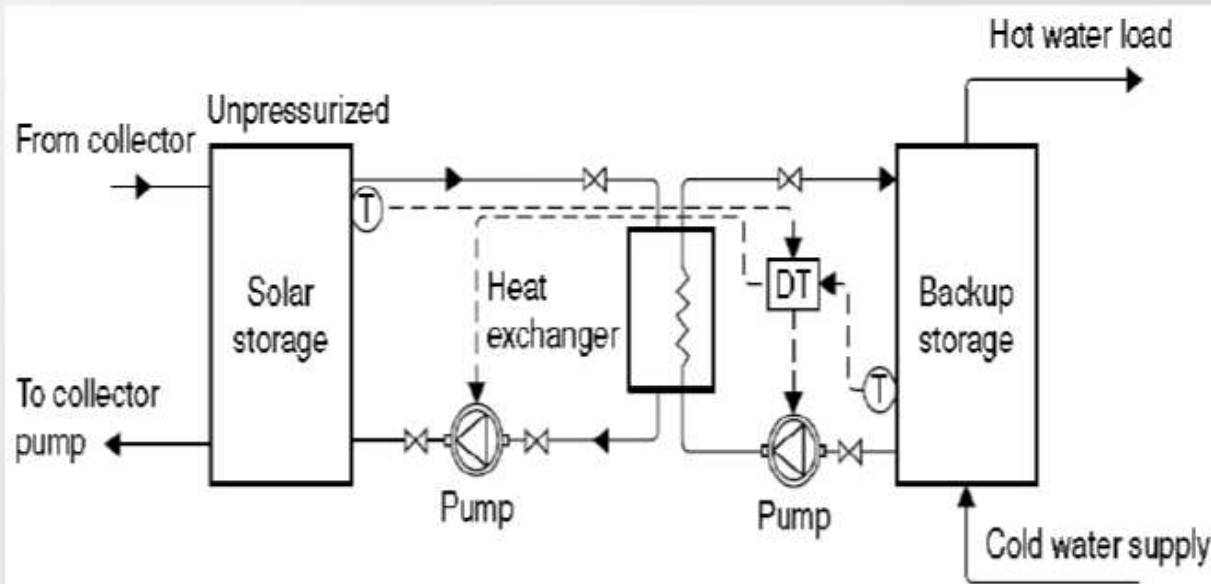

Ex



Q1) a-) On what basic principle, does the thermosiphon solar water heating system work? [13 Mark]

b- Give only two from the advantages and limitations of a solar water heating system. [12 Mark]

Q2) What are the most important function of storage tank, define phase change material (PCM) give an example for this case and describe with schematic diagram of a vertical flow bed. [25 Mark].

Q3) To types of liquid system thermal storage are available.

Q 4) Define the following: (only four)

1- Integrated collector storage , 2- Thermos siphon system , 3- flat plate solar collector , 4 - Pressurized systems, 5- Active Systems, 6- solar ponds [20Mark].

