

# Post-transcriptional regulation (Modification)

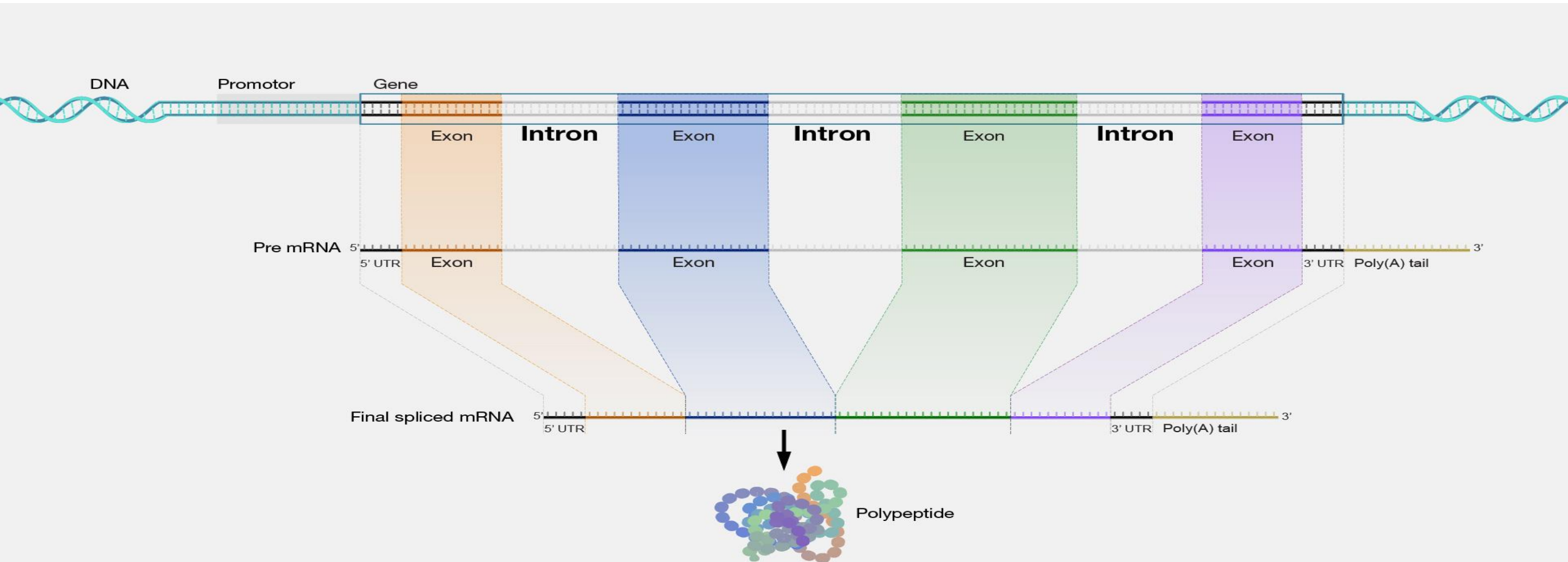

# Post-transcriptional regulation(Modification)

- **Post-transcriptional regulation** can be used to regulate the active amount of RNA by modification. It occurs between the transcription phase and the translation phase of gene expression,
- **In prokaryotic cell**, RNA transcripts are ready to act as mRNAs and get translated into proteins right away, **but in Eukaryotic cell**, pre-mRNA needs to go through a few more steps to become an actual mRNA(mature mRNA).

# These modifications include:-

- processing includes Additions of 5' cap and poly-A tail. Both the cap and the tail protect the transcript and help it get exported from the nucleus and translated on the ribosomes (protein-making "machines") found in the cytosol
- **A- Adding cap structure:** A 7-methylguanosine cap is added to the 5' end of the growing transcript by a phosphate linkage.
- The cap protects the transcript from being broken down and helps the ribosome attach to the mRNA and start reading it to make a protein.
- **B- Polyadenylation (poly Adenine residue):** Once elongation is complete, the pre-mRNA is cleaved by an endonuclease between an **AAUAAA consensus sequence** and a **GU-rich sequence**, leaving the AAUAAA sequence on the pre-mRNA.

- An enzyme called poly(A) polymerase then adds a string of approximately 100 - 200 A residues, called the poly-A tail. The tail makes the transcript more stable and helps it get exported from the nucleus to the cytosol.

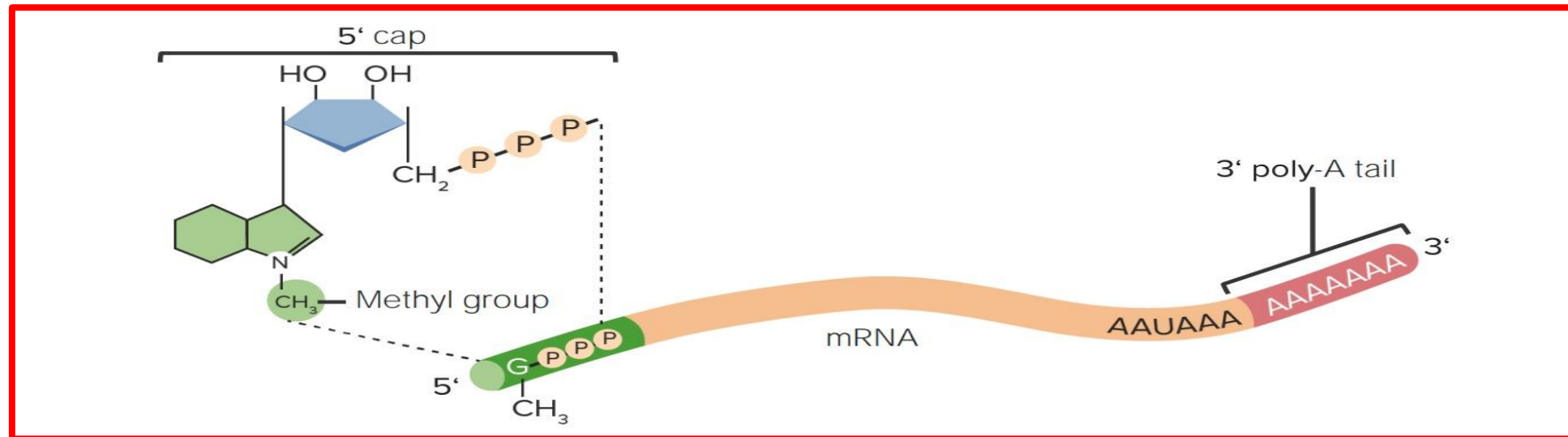

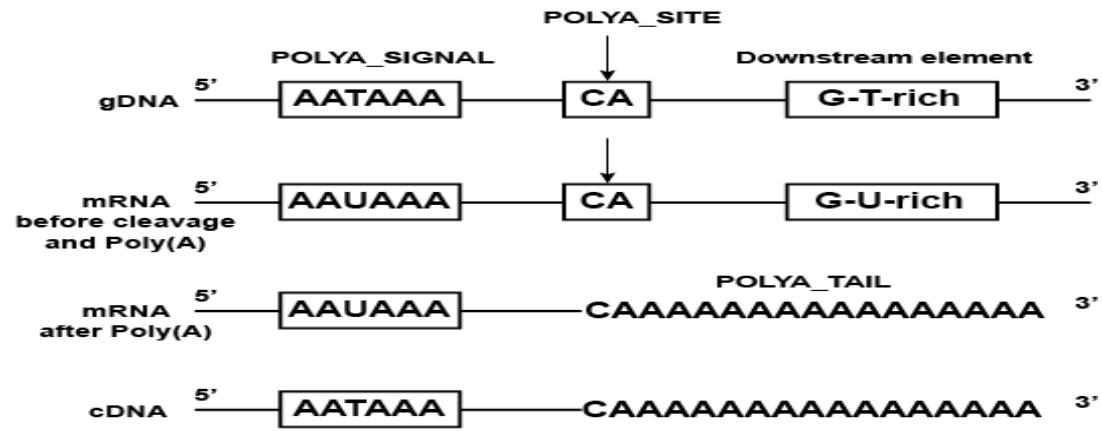
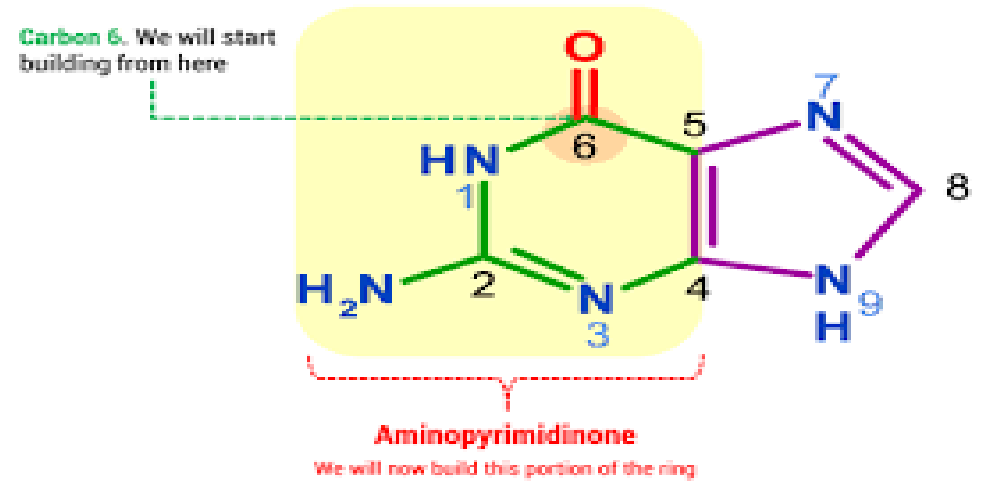
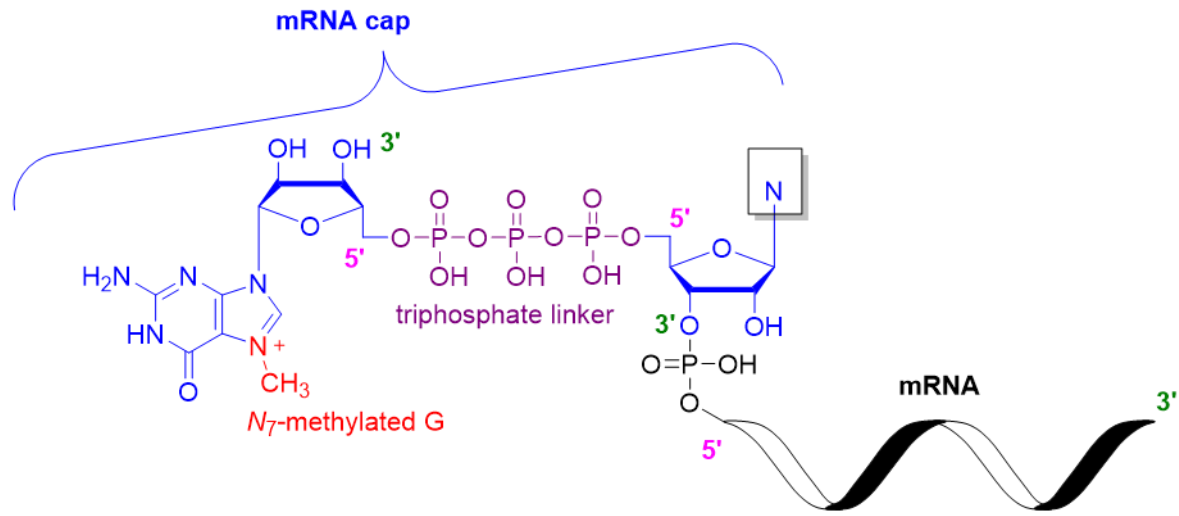

- **2- Splicing** : Eukaryotic genes are composed of exons, which correspond to protein-coding sequences (**exon** signifies that they are expressed), and intervening sequences called (sequences in mRNA do not encode functional proteins). **introns**
- **The process of removing introns and reconnecting exons is called splicing.**
- Introns are removed and degraded while the pre-mRNA is still in the nucleus.
- The splicing process is catalyzed by protein complexes called **spliceosomes**
- that are composed of **proteins and RNA molecules** called **small nuclear RNAs (snRNAs)**.
- Usually the transcript mRNA is shorter than the origin gene it-self.

# Splicing includes:-

- 1-The first cleavage occur by splicesome machine at 5' end of the intron region rich with GU residue
- 2- Then the intron bend back to form lariat structure via 5'→3' phosphodiester bond.
- 3- Cleavage at 3' end of the intron to completely released
- 4- Joining the exons by ligase enzyme to give arise to mature mRNA .

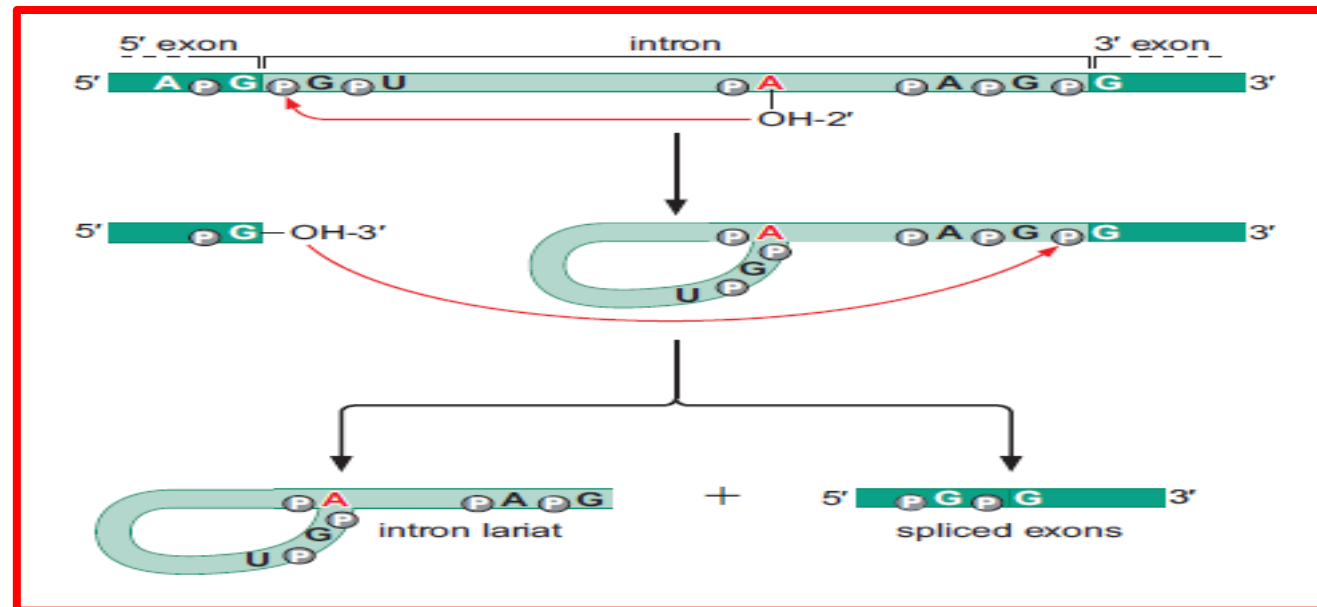

# Alternative splicing

- Is an alternative splicing process during gene expression that allows a single gene to code for multiple proteins. In this process, particular exons of a gene may be included within or excluded from the final, processed messenger RNA(mRNA) produced from that gene. This means the exons are joined in different combinations, leading to different (alternative) mRNA strands. Consequently, the proteins translated from alternatively spliced mRNA usually contain differences in their amino acid sequence and, often, in their biological functions.



# Alternative splicing

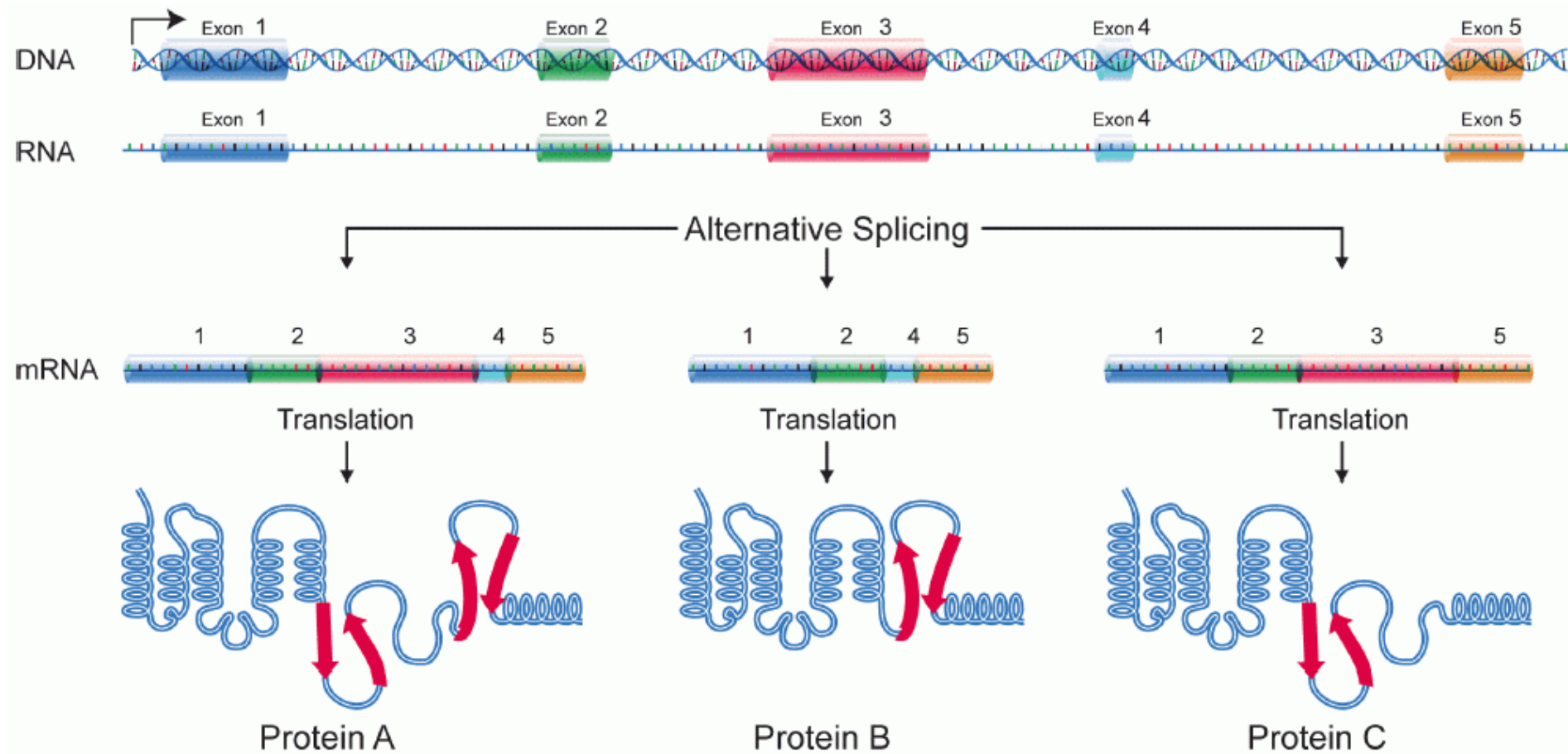

- Mature mRNA is a single-stranded RNA molecule, carries information from DNA to the ribosome, **the sites of protein synthesis (translation) in the cell.**
- The coding sequence of the mRNA **determines** the amino acid sequence in the protein .

# The basic differences in mRNA structure in prokaryotic and eukaryotic

- The **main difference** between prokaryotic and eukaryotic mRNA is that prokaryotic mRNA is **Polycistronic**, whereas eukaryotic mRNA is **Monocistronic**. Furthermore, **several structural genes** of an operon are transcribed into a **single mRNA** while eukaryotic mRNA contains a single gene transcribed into an mRNA molecule.

### Prokaryotic mRNA

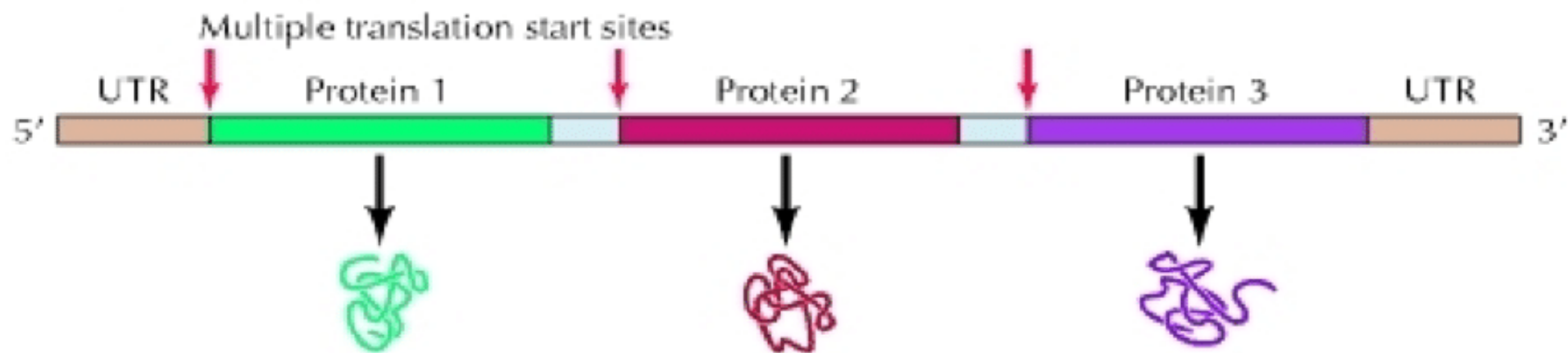

### Eukaryotic mRNA

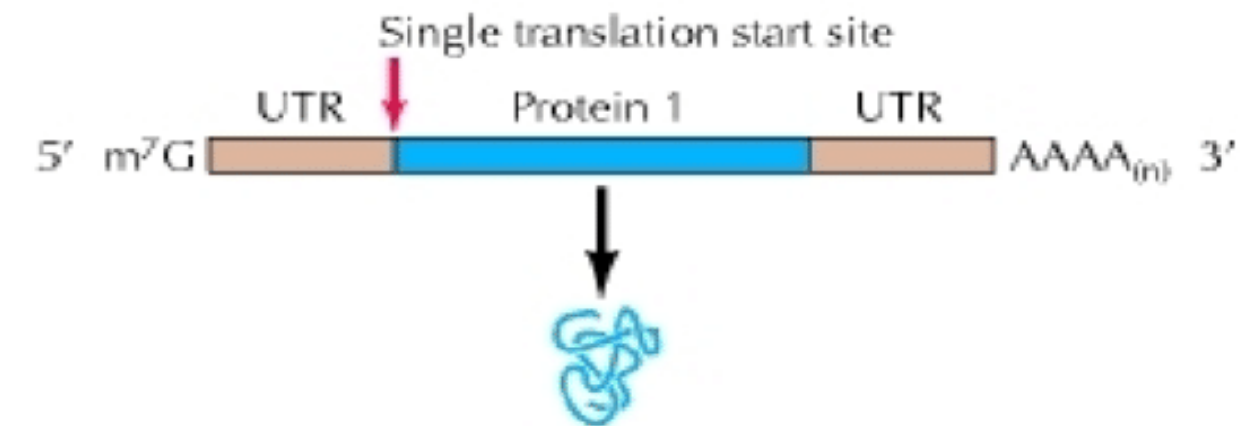

- (2) prokaryote mRNA is very short lived in *E. coli* half-lives range from **10s-20min**. Therefore it is degraded primarily after translation has been initiated.
- Short life span of mRNA enables prokaryotes to synthesize different proteins or enzymes in response to changes in the external environment. On other hand,
- **Eukaryote mRNAs** are more stable in yeast half-lives range from **1 – 60 min**.
- Prokaryotic transcription occurs in the cytoplasm alongside translation. Prokaryotic transcription and translation can occur simultaneously. This is impossible in eukaryotes, where transcription occurs in a membrane-bound **nucleus** while translation occurs outside the nucleus in the **cytoplasm**.

- 4) In prokaryotes the primary mRNA transcript is functional as soon as it is synthesized. In eukaryotes, however, the RNA transcript must undergo processing before it is a functional mRNA. This processing occurs in the nucleus and involves three steps: 5' capping, 3' Polyadenylation (polyA tailing), and exon splicing.
- (5) In prokaryotic mRNA cells start (5' end) with Leader sequence (upstream region; 5' UTR) that contains a ribosome binding site (RBS), also known as the Shine–Dalgarno sequence, which is usually 3–10 base pairs upstream from the initiation codon.
- The mRNA ends (3' end) with un-translated region (3'-UTR or tailer sequence) is the section of mRNA that immediately follows the translation termination codon. The 3'-UTR often contains regulatory regions that post-transcriptionally influence gene expression.

## Shine-Dalgarno sequence in prokaryotes only

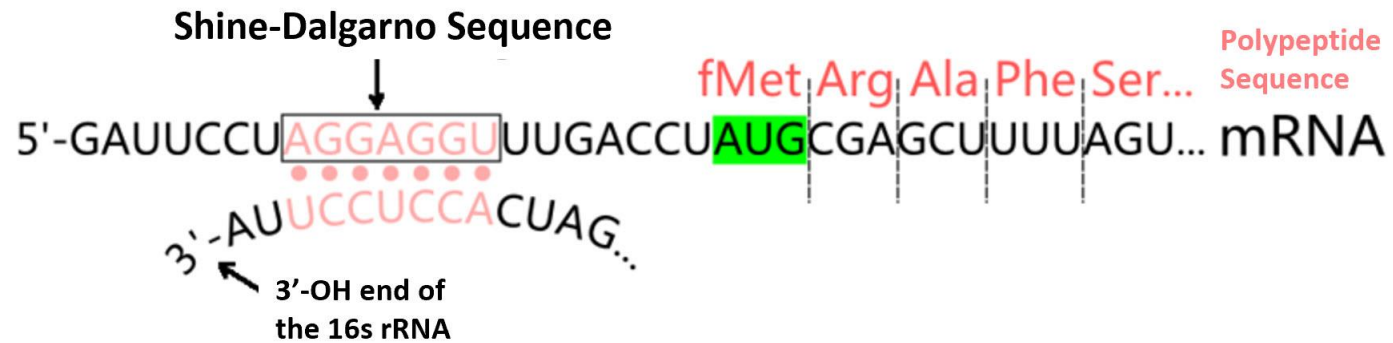
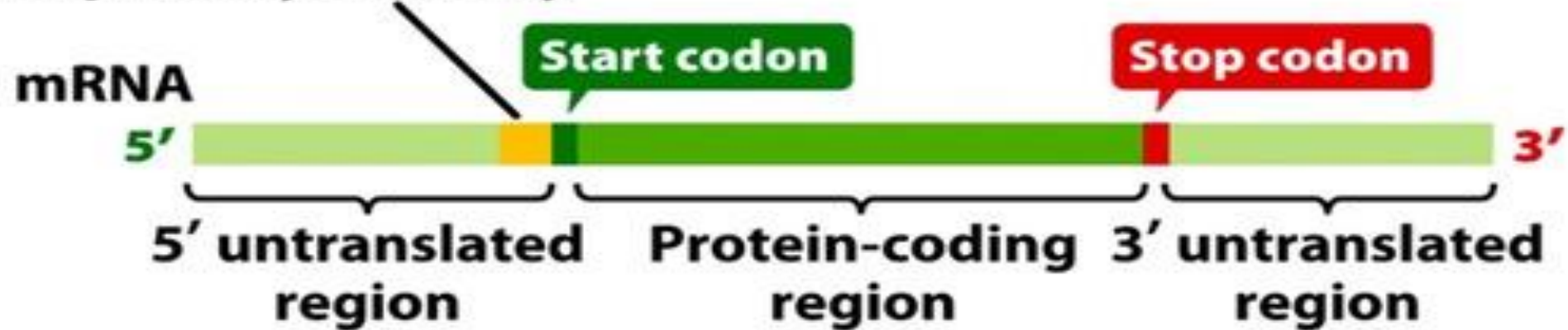

# Shine–Dalgarno (SD) sequence

- Is a ribosomal binding site, generally located around 8 bases upstream of the start codon **AUG**. The RNA sequence helps recruit the ribosome to the messenger RNA (mRNA) to initiate protein Synthesis by aligning the ribosome with the start codon.
- The Shine–Dalgarno sequence is common in bacteria, but rarer in archaea .It is also present in some chloroplast and mitochondria transcripts. The six-base consensus sequence is **AGGAGG**; in *Esherichia coli* for example, the sequence is **AGGAGGU**.
- The Shine–Dalgarno sequence was proposed by **Australian** scientists **John Shine** and **Lynn Dalgarno** in 1973.



- Most eukaryotic 5'UTR region includes the Kozak consensus sequence (ACCAUGG) which contains the start codon (AUG) to initiate translation.
- The eukaryotic 5' UTR also contains cis-acting regulatory elements called upstream open reading frames (uORFs) and upstream AUGs (uAUGs) and termination codons, which have a great impact on the regulation of translation

