

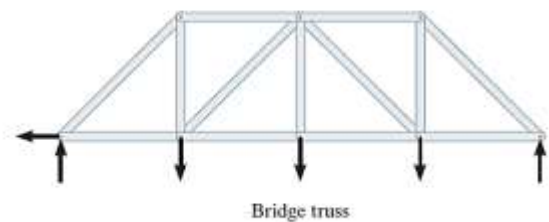

4.2 Analysis of Trusses

A *truss* is a structure composed of slender members joined together at their end points. Each member of the truss is either in tension or compression.

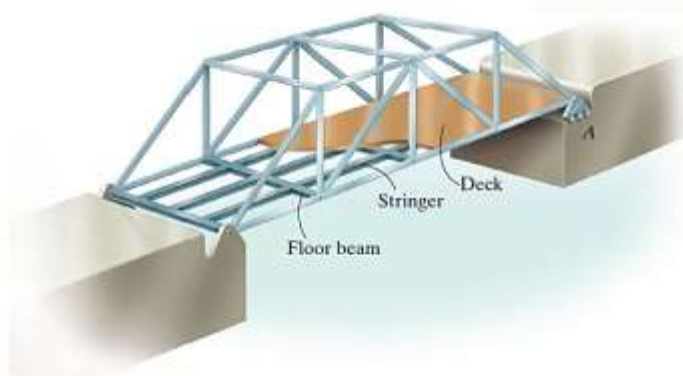

Assumptions for Design:

1. The members of truss are joined together by smooth pins at their end.
2. The loads and reaction act only at the joints.
3. The weight of the members can be neglected.

Method of Analysis:

1. Method of Joints ($\sum F_x = 0, \sum F_y = 0$)
2. Method of Sections ($\sum F_x = 0, \sum F_y = 0, \sum M_o = 0$)
3. Mixed Method (Joints + Section)

4.2.1 Method of Joints

The free-body diagram of any joint is a [coplanar concurrent force system](#) in which the summation of moment will be of no help. Therefore, only two equilibrium equations can be used:

$$\sum F_x = 0 \dots\dots\dots (1)$$

$$\sum F_y = 0 \dots\dots\dots (2)$$

When using the method of joints, always start at a joint having at least one known force and at most two unknown forces. Always assume the unknown member forces acting on the joint's free-body diagram to be in tension. If this is done, then solution of the equilibrium equations will result positive scalars for members in tension (T) and negative scalars for members in compression (C).

Zero-Force Members:

Truss analysis using the method of joints is greatly simplified if we can first identify those members which support no loading. These zero-force members are used to increase the stability of the truss during construction and to provide added support if the loading is changed.

❖ *If only two non-collinear members form a truss joint and no external load or support reaction is applied to the joint, the two members must be zero-force members.*

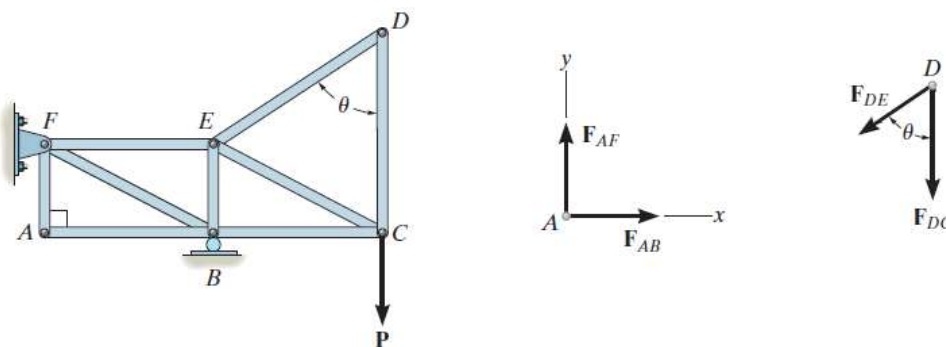

At Joint A:

$$\rightarrow^+ \sum F_x = 0 \Rightarrow F_{AB} = 0$$

$$\uparrow^+ \sum F_y = 0 \Rightarrow F_{AF} = 0$$

At Joint D:

$$\rightarrow^+ \sum F_x = 0 \Rightarrow F_{DE} \sin \theta = 0 \Rightarrow F_{DE} = 0$$

$$\uparrow^+ \sum F_y = 0 \Rightarrow -F_{DC} - 0 = 0 \Rightarrow F_{DC} = 0$$

❖ If three members form a truss joint for which two of the members are collinear, the third member is a zero-force member provided no external force or support reaction is applied to the joint.

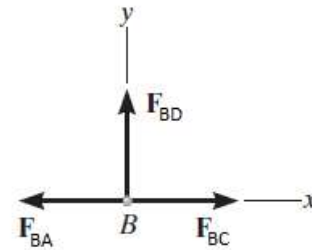
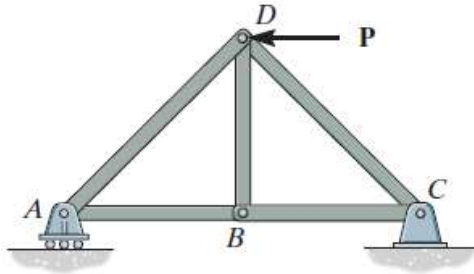

At Joint B:

$$\uparrow^+ \sum F_y = 0 \Rightarrow F_{BD} = 0$$

Example No. 1: Determine the force in each member of the truss shown in Figure. Indicate whether the members are in tension or compression.

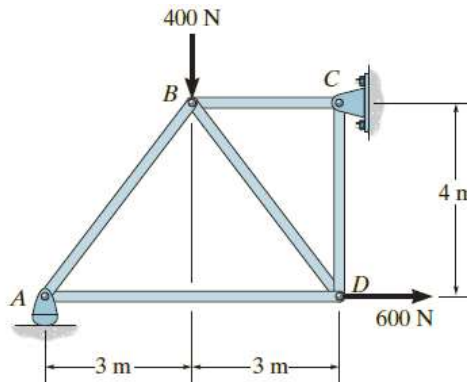

Solution:

From the whole truss as F.B.D:

$$\curvearrowright^+ \sum M_C = 0$$

$$A_y \times 6 - 400 \times 3 - 600 \times 4 = 0$$

$$A_y = 600 \text{ N } \uparrow$$

$$\rightarrow^+ \sum F_x = 0$$

$$-C_x + 600 = 0 \Rightarrow C_x = 600 \text{ N } \leftarrow$$

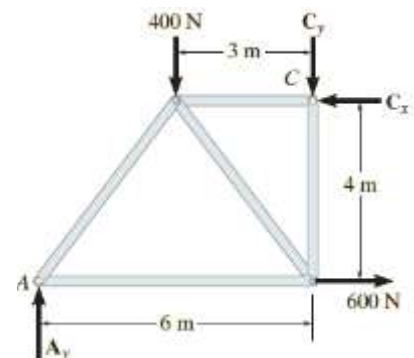

$$\uparrow^+ \sum F_y = 0$$

$$600 - 400 - C_y = 0 \Rightarrow C_y = 200 \text{ N } \downarrow$$

At Joint A:

$$\uparrow^+ \sum F_y = 0$$

$$600 + F_{AB} \times \frac{4}{5} = 0$$

$$F_{AB} = -750 \text{ N} = 750 \text{ N (C)}$$

$$\rightarrow^+ \sum F_x = 0$$

$$F_{AD} - 750 \times \frac{3}{5} = 0 \Rightarrow C_x = 450 \text{ N (T)}$$

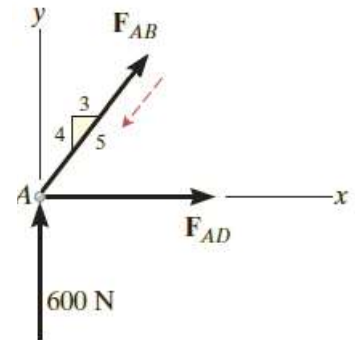

At Joint D:

$$\rightarrow^+ \sum F_x = 0$$

$$-F_{DB} \times \frac{3}{5} - 450 + 600 = 0$$

$$F_{DB} = 250 \text{ N (T)}$$

$$\uparrow^+ \sum F_y = 0$$

$$250 \times \frac{4}{5} + F_{DC} = 0 \Rightarrow F_{DC} = -200 \text{ N} = 200 \text{ N (C)}$$

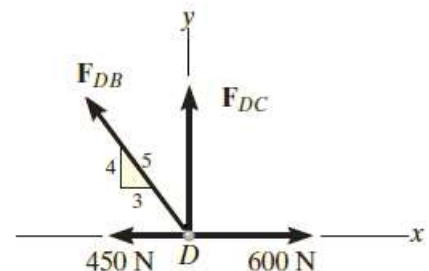

At Joint C:

$$\rightarrow^+ \sum F_x = 0$$

$$-F_{CB} - 600 = 0$$

$$F_{DB} = -600 \text{ N} = 600 \text{ N (C)}$$

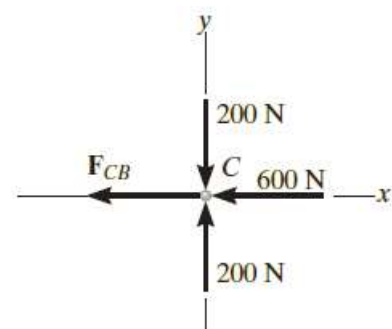

Example No. 2: Using the method of joints, determine all the zero-force members of the truss shown in Figure. Assume all joints are pin connected.

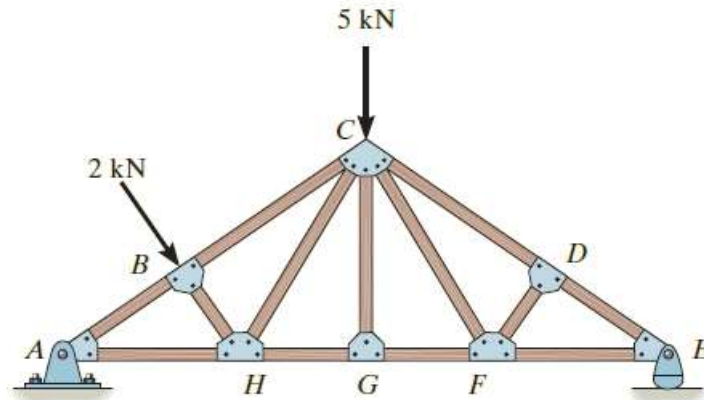

Solution:

Look for joint geometries that have three members for which two are collinear.

We have:

ابحث عن الأشكال الهندسية للمفاصل التي تحتوي على ثلاثة أعضاء بحيث يكون اثنان على خط واحد

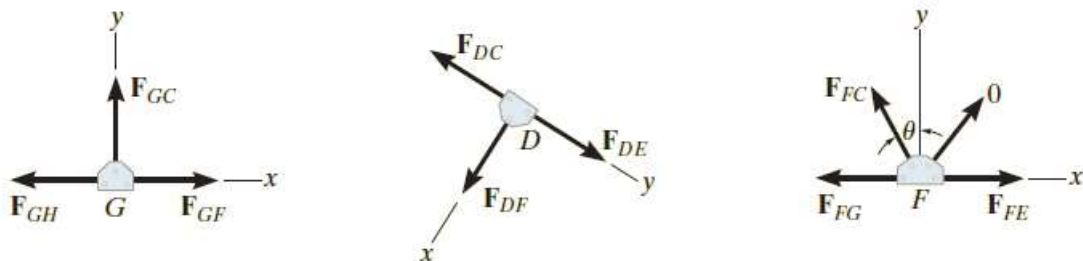

Joint G:

$$\uparrow^+ \sum F_y = 0 \Rightarrow F_{GC} = 0$$

Joint D:

$$+\swarrow \sum F_x = 0 \Rightarrow F_{DF} = 0$$

Joint F:

$$\uparrow^+ \sum F_y = 0 \Rightarrow F_{FC} \cos \theta + 0 = 0 \Rightarrow F_{FC} = 0$$

Problems:

1. The cantilever truss in Figure is hinged at D and E. Find the force in each member.

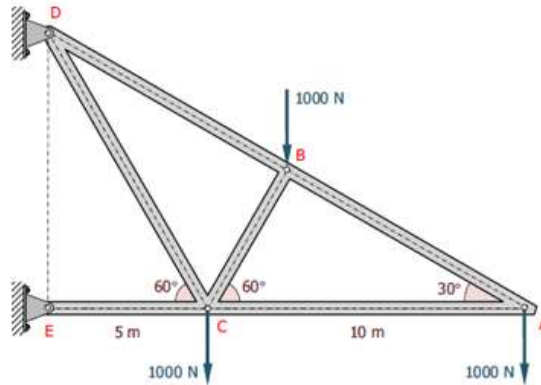

Answer:

- $F_{AB} = 2000 \text{ N tension}$
- $F_{AC} = 1732.05 \text{ N compression}$
- $F_{BC} = 866.02 \text{ N compression}$
- $F_{BD} = 2500 \text{ N tension}$
- $F_{CD} = 2020.72 \text{ N tension}$
- $F_{CE} = 3175.42 \text{ N compression}$

2. Determine the force in members AB, BD, BE, and DE of the Howe roof truss shown in Figure.

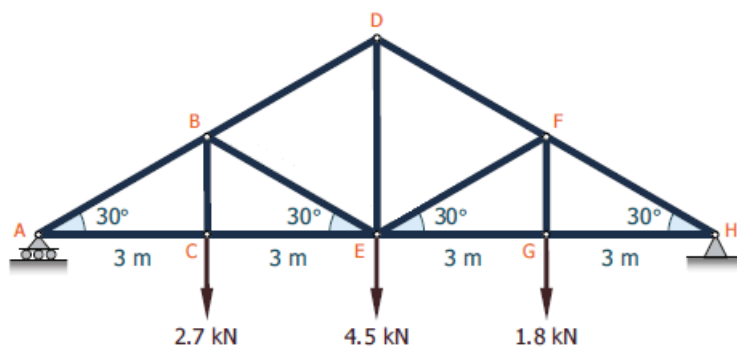

Answer:

- $F_{AB} = 9.45 \text{ kN compression}$
- $F_{BE} = 2.7 \text{ kN compression}$
- $F_{BD} = 6.75 \text{ kN compression}$
- $F_{DE} = 6.75 \text{ kN tension}$

3. Determine the force in each member of the truss, and state if the members are in tension or compression.

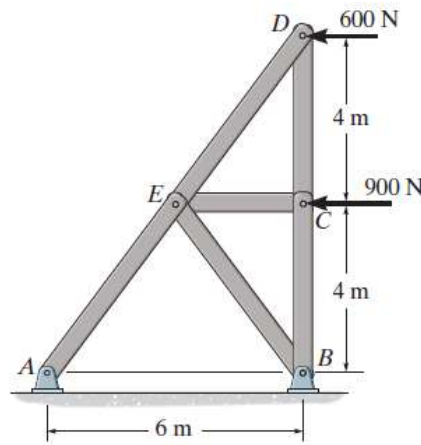

Answer:

$$F_{DE} = 1.00 \text{ kN } C$$

$$F_{DC} = 800 \text{ N } T$$

$$F_{CE} = 900 \text{ N } C$$

$$F_{CB} = 800 \text{ N } T$$

$$F_{EB} = 750 \text{ N } T$$

$$F_{EA} = 1.75 \text{ kN } C$$

4. Identify the zero-force members in the truss.

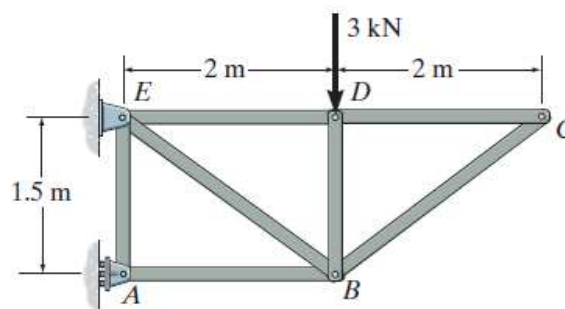

Answer:

$$F_{CB} = 0$$

$$F_{CD} = 0$$

$$F_{AE} = 0$$

$$F_{DE} = 0$$