



3.2 Equilibrium of Coplanar Concurrent Force system

The resultant of coplanar concurrent force system is:

$$R = \sqrt{R_x^2 + R_y^2}$$

To achieve the equilibrium, the resultant must be equal to zero (i.e. $R = 0$), then:

$$R_x = 0 \Rightarrow \sum F_x = 0 \dots\dots\dots (1)$$

$$R_y = 0 \Rightarrow \sum F_y = 0 \dots\dots\dots (2)$$

Only two unknowns can be determined

Example No. 1: Determine the force (F) in the figure below which must be applied to ring A in order to keep the 300 N cylinder B in equilibrium.

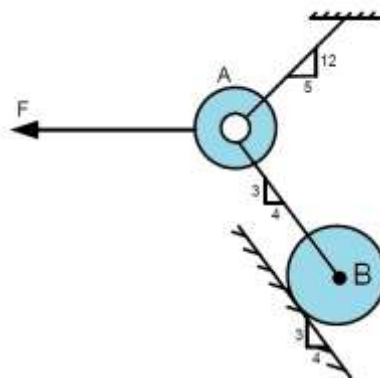

Solution:

Draw F.B.D. for Ring (A) and cylinder (B):

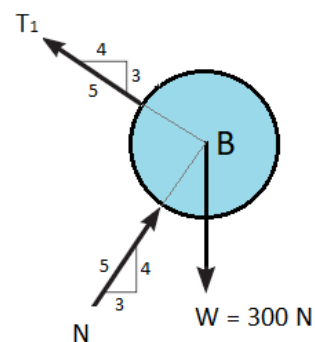
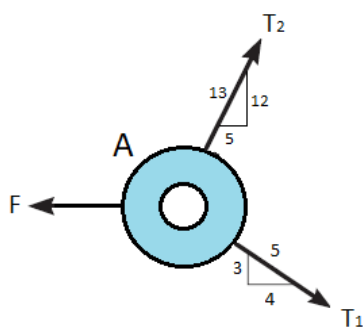

at cylinder (B):

$$\rightarrow^+ \sum F_x = 0$$

$$N \times \frac{3}{5} - T_1 \times \frac{4}{5} = 0$$

$$N = 1.333 T_1 \dots \dots \dots (1)$$

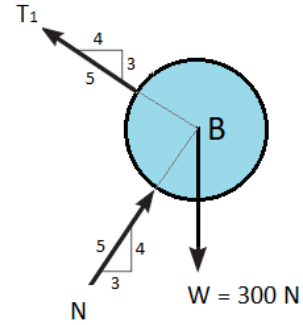

$$\uparrow^+ \sum F_y = 0$$

$$N \times \frac{4}{5} + T_1 \times \frac{3}{5} - 300 = 0$$

$$1.333 T_1 \times \frac{4}{5} + T_1 \times \frac{3}{5} = 300$$

$$\therefore T_1 = 180 N$$

at Ring (A):

$$\uparrow^+ \sum F_y = 0$$

$$-180 \times \frac{3}{5} + T_2 \times \frac{12}{13} = 0$$

$$\therefore T_2 = 117 N$$

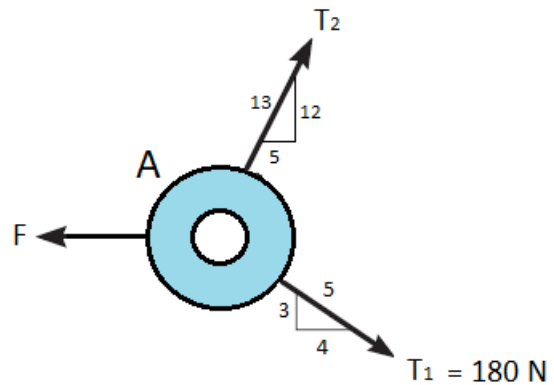

$$\rightarrow^+ \sum F_x = 0$$

$$180 \times \frac{4}{5} + 117 \times \frac{5}{13} - F = 0$$

$$\therefore F = 189 N \leftarrow \text{answer}$$

Example No. 2: The 290 N pipe is supported at A by a system of five-cords. Determine the force in each cord for equilibrium.

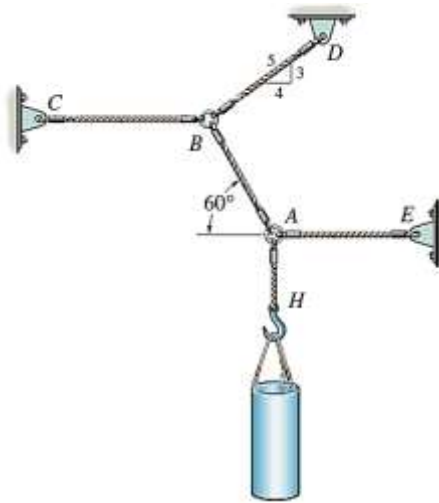

Solution:

Draw F.B.D. for system:

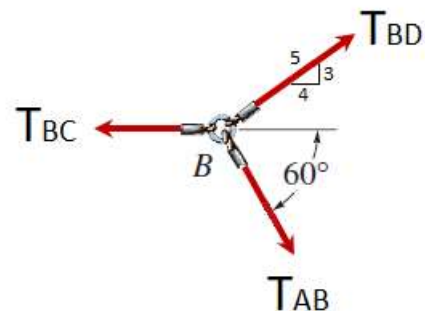
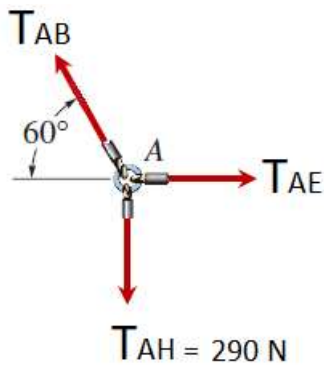

From F.B.D. of Ring A:

$$\uparrow^+ \sum F_y = 0$$

$$T_{AB} \sin 60 - 290 = 0 \quad \rightarrow \quad T_{AB} = \frac{290}{\sin 60}$$

$$\therefore T_{AB} = 334.86 \text{ N} \quad \text{answer}$$

$$\rightarrow^+ \sum F_x = 0$$

$$T_{AE} - 334.86 \times \cos 60 = 0$$

$$T_{AE} = 167.43 \text{ N} \quad \text{answer}$$

From F.B.D. of Ring B:

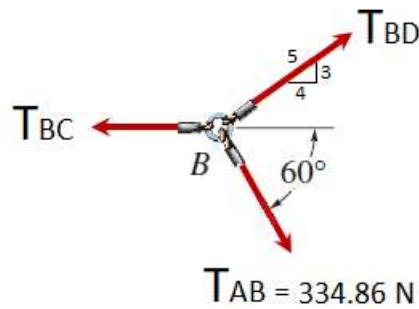

$$\uparrow^+ \sum F_y = 0$$

$$T_{BD} \times \frac{3}{5} - 334.86 \times \sin 60 = 0$$

$$\therefore T_{BD} = 483.33 \text{ N} \quad \text{answer}$$

$$\rightarrow^+ \sum F_x = 0$$

$$483.33 \times \frac{4}{5} + 334.86 \times \cos 60 - T_{BC} = 0$$

$$T_{BC} = 554.094 \text{ N} \quad \text{answer}$$

Problem:

- Determine the tension developed in each cord required for equilibrium of the 20 kg lamp.

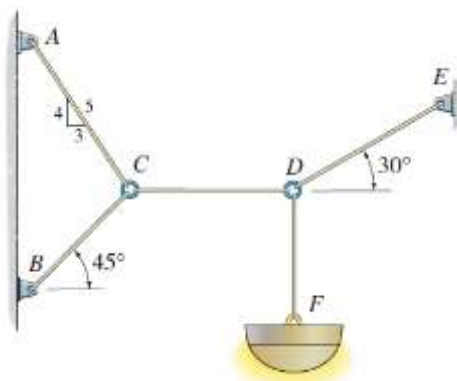

Answer: $T_{DE} = 392.4 \text{ N}$, $T_{CD} = 339.83 \text{ N}$, $T_{CB} = 274.62 \text{ N}$, $T_{CA} = 242.73 \text{ N}$

2. A system of cables connected together at A required for equilibrium of the 20 kg ball D as shown in the figure. Determine the largest dimension d so that the force in cable AC is zero and $F = 100$ N.

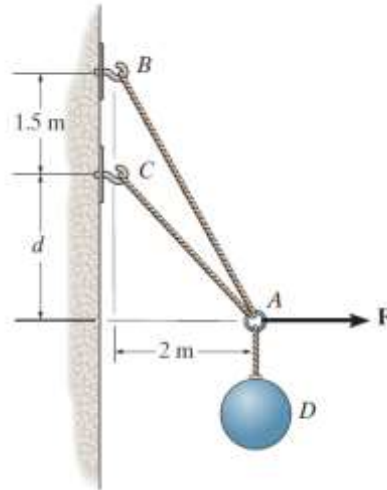

Answer: $d = 2.42$ m

3. Determine the force in each rod for equilibrium of the 250 N crate.

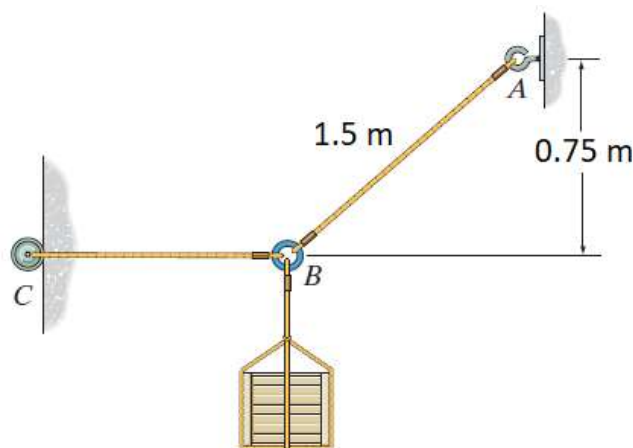

Answer: $T_{AB} = 500$ N, $T_{CB} = 433.33$ N