

Pile load test

In most large projects, a specific number of load tests must be conducted on piles. The primary reason is the unreliability of prediction methods. The vertical and lateral loadbearing capacity of a pile can be tested in the field. Figure 1a shows a schematic diagram of the pile load arrangement for testing *axial compression* in the field. The load is applied to the pile by a hydraulic jack. Step loads are applied to the pile, and sufficient time is allowed to elapse after each load so that a small amount of settlement occurs. The settlement of the pile is measured by dial gauges. The amount of load to be applied for each step will vary, depending on local building codes. Most building codes require that each step load be about one-fourth of the proposed working load. The load test should be carried out to at least a total load of two times the proposed working load. After the desired pile load is reached, the pile is gradually unloaded.

في معظم المشاريع الكبيرة، يجب إجراء عدد محدد من اختبارات الحمل على الركائز. السبب الرئيسي هو عدم موثوقية طرق التقليدية لحساب قوة التحمل. يمكن اختبار قدرة الحمل الرأسي والجانبي للركيزة في حقل العمل. يوضح Fig.1a رسمًا تخطيطيًا لحميل الركيزة لاختبار الضغط المحوري في الحقل. يتم تطبيق الحمل على الركيزة بواسطة رافعة هيدروليكية بشكل تدريجي. ويتم السماح بمرور وقت كافٍ بعد كل حمل بحيث يحدث قدر صغير من الهبوط. يتم قياس هبوط الركيزة بواسطة مقاييس خاص dial gage. ويزداد مقدار الحمل الذي سيتم تطبيقه لكل خطوة، اعتمادًا على الكود المحلي لكل بلد. تتطلب معظم كودات البناء أن يكون حمل كل خطوة حوالي ربع الحمل الكلي المقترح للركيزة. يجب إجراء اختبار الحمل على حمولة إجمالية لا تقل عن ضعف حمل العمل المقترح للركيزة. بعد الوصول إلى ضعف الحمل المقترح، يتم رفع الأثقال تدريجيًا عن الركيزة تحت الفحص.

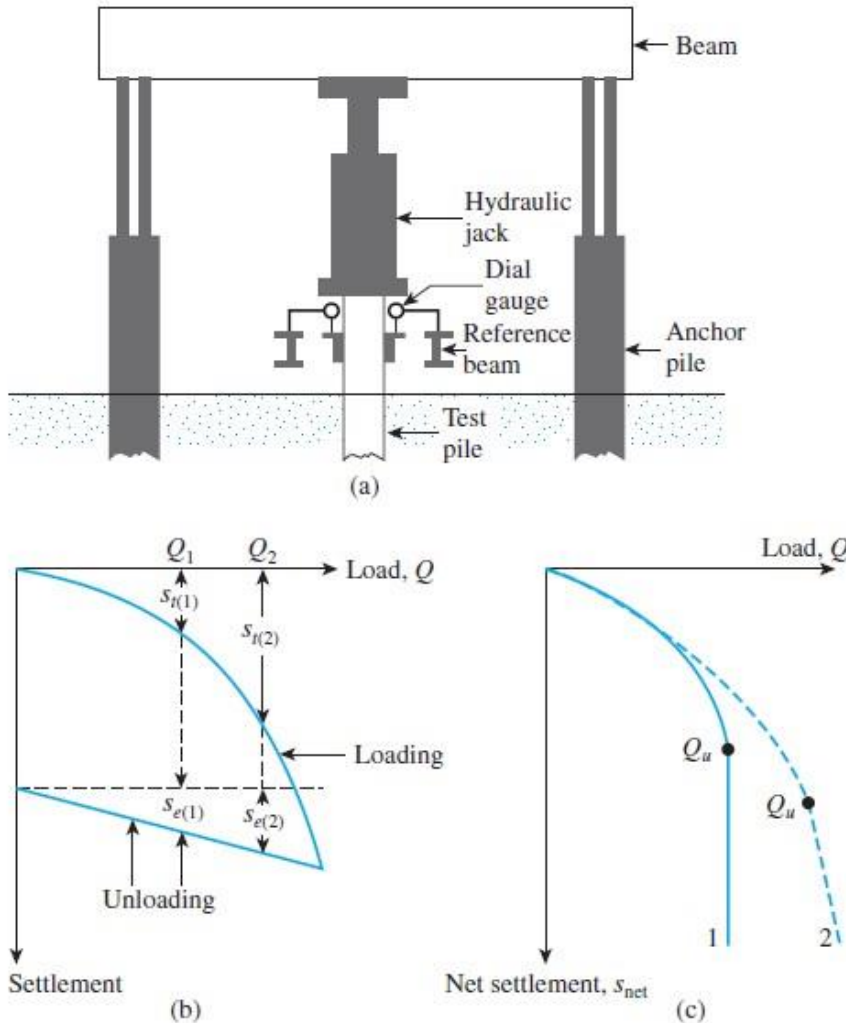

(a) Schematic diagram of pile load test arrangement (b) plot of load against total settlement; (c) plot of load against net settlement

Fig.1b shows a load–settlement diagram obtained from field loading and unloading. For any load Q, the net pile settlement can be calculated as follows:

When $Q = Q_1$, $Net\ settlement, S_{Net(1)} = S_{t(1)} - S_{e(1)}$

When $Q = Q_2$, $Net\ settlement, S_{Net(2)} = S_{t(2)} - S_{e(2)}$

And so on

Where

S_{Net} : Net settlement of pile , S_e : Elastic settlement , S_t : Total settlement

These values of Q can be plotted in a graph against the corresponding net settlement S_{Net} , as shown in Fig. 1c. The ultimate load of the pile can then be determined from the graph.

Pile settlement may increase with load to a certain point, beyond which the load–settlement curve becomes vertical. The load corresponding to the point where the curve of Q versus S_{Net} becomes vertical is the ultimate load, for the pile; it is shown by curve 1 in Fig.1c.

Example: A pile load test was carried on a square pile of 20m length and 0.35m*0.35m cross section was desired to be loaded with a working load 1000 KN. Determine the ultimate load if the test results were tabulated in the following table.

Loads KN	S_t , mm	$S_{e(1)}$, mm	S_{Net} , mm
0	0	0	0
250	1.45	1.25	0.2
500	3.23	2.5	0.73
750	5.5	3.75	1.75
1000	9	5	4
1250	12	6.25	5.75
1500	17	7.5	9.5
1750	23	8.75	14.25
2000	35	10	25

