



**جامعة المستقبل**  
**كلية الهندسة والتقنيات الهندسية**  
**قسم هندسة تقنيات الاجهزة الطبية**  
Course: Digital Signal Processing

Edited By  
Professor Dr Bayan Mahdi Sabbar  
&  
Dr. Tarik Al-Khateeb

**Third Year 2023-2024**

# Lecture 11 & 12

**(Discrete Fourier Transform and Signal Spectrum)**

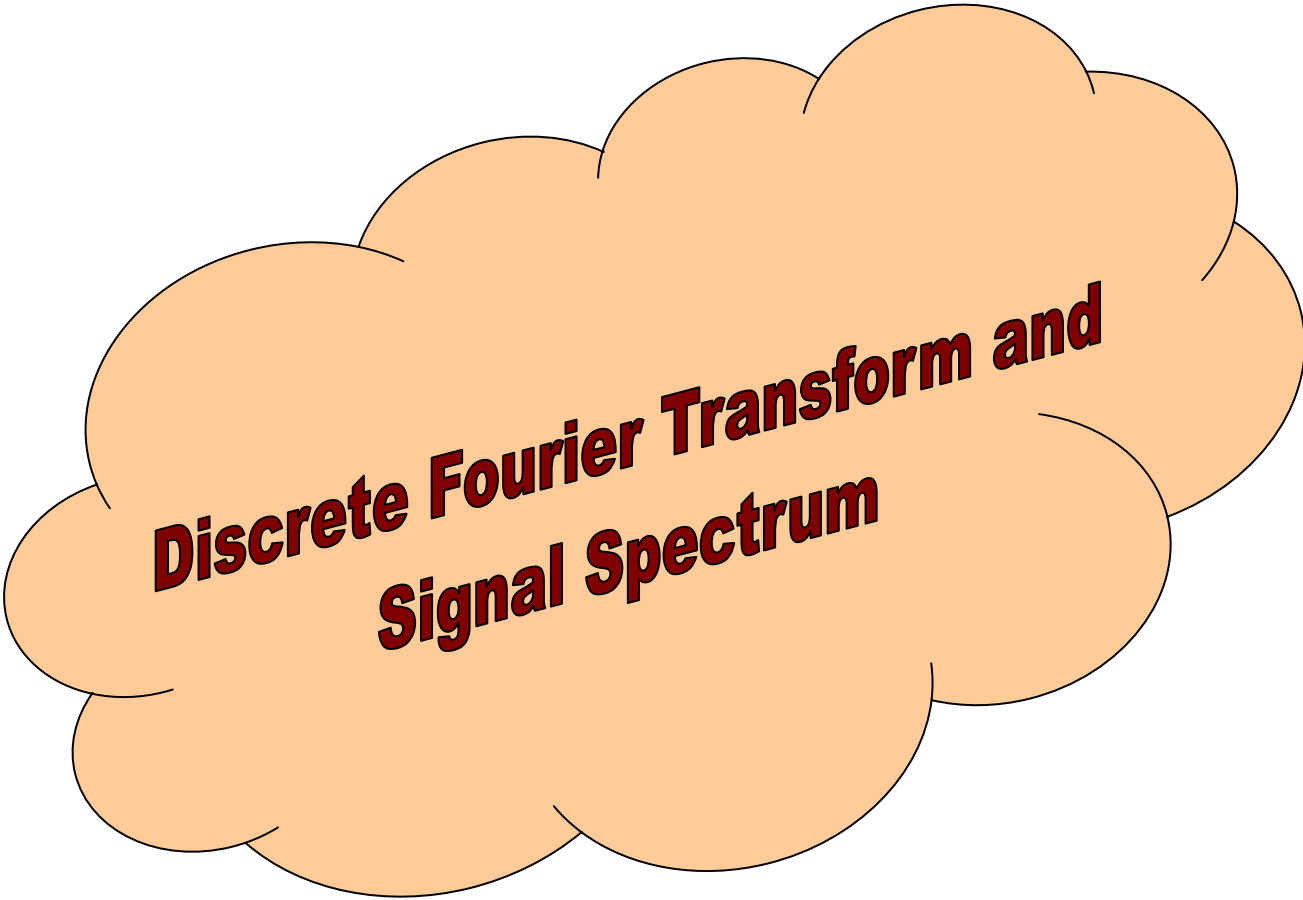

**Discrete Fourier Transform and  
Signal Spectrum**



*11th & 12th modular units*

# 1/ Overview

## 1 / A –Target population :-

For students of third class

Department of Medical Instrumentation Eng. Techniques

## 1 / B –Rationale :-

In time domain, representation of digital signals describes the signal amplitude versus the sampling time instant or the sample number. However, in some applications, signal frequency content is very useful otherwise than as digital signal samples. The representation of the digital signal in terms of its frequency component in a frequency domain, that is, the signal spectrum, needs to be developed.

The algorithm transforming the time domain signal samples to the frequency domain components is known as the discrete Fourier transform, or DFT. The DFT also establishes a relationship between the time domain representation and the frequency domain representation. Therefore, we can apply the DFT to perform frequency analysis of a time domain sequence.

In addition, the DFT is widely used in many other areas, including spectral analysis, acoustics, imaging/video, audio, instrumentation, and communications systems.

### **1 / C –Central Idea :-**

This unit investigates discrete Fourier transform (DFT) and their properties; introduces the DFT algorithms to compute signal amplitude spectrum and power spectrum. It is cover the following topics:

- 1. Discrete Fourier Transform**
- 2. Fourier Series Coefficients of Periodic Digital Signals**
- 3. Discrete Fourier Transform Formulas**
- 4. Amplitude Spectrum and Power Spectrum**

### **2/ Performance Objectives :-**

After studying the 6<sup>th</sup> modular unit, the student will be able to:-

1. Define DFT.
2. Know the methods of compute DFT.
3. Know the methods of compute amplitude spectrum and power spectrum.

### 3/ Pre test :-

Circle the correct answer :-

1. **Time domain representation of discrete time signal is:-**
  - a- Signals amplitude versus samples number.
  - b- Signals power versus time.
  - c- Signals energy versus samples number.
  - d- Signals spectrum versus time.
2. **Frequency domain representation of discrete time signal is:-**
  - a. Signals amplitude versus frequency.
  - b. Signals spectrum versus frequency.
  - c. Signals power versus frequency.
  - d. Signals energy versus samples number.
3. **Discrete Fourier Transform is the algorithm relating :-**
  - a- Amplitude and spectrum.
  - b- Power and energy.
  - c- Time domain and frequency domain.
  - d- Filtering the discrete time signals.

## 4/ the text :-

### Discrete Fourier Transform

Figure below illustrates the time domain representation of a 1,000-Hz sinusoid with 32 samples at a sampling rate of 8,000 Hz; the bottom plot shows the signal spectrum (frequency domain representation), where we can clearly observe that the amplitude peak is located at the frequency of 1,000 Hz in the calculated spectrum. Hence, the spectral plot better displays frequency information of a digital signal.

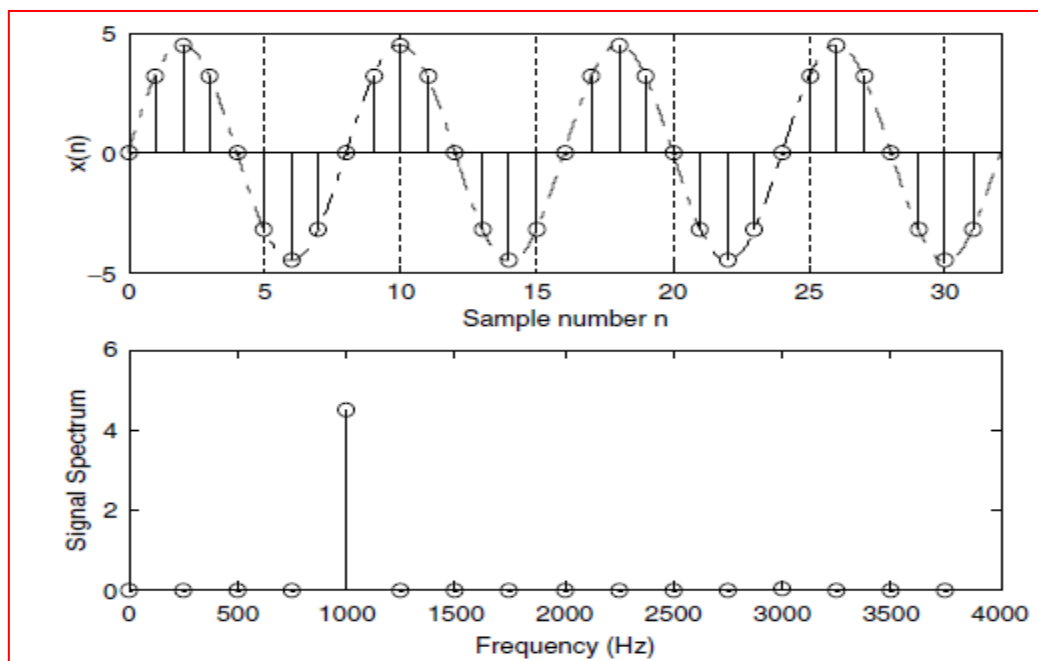

The algorithm transforming the time domain signal samples to the frequency domain components is known as the discrete Fourier transform, or DFT.

The DFT also establishes a relationship between the time domain representation and the frequency domain representation. Therefore, we can apply the DFT to perform frequency analysis of a time domain sequence.



## Fourier Series Coefficients of Periodic Digital Signals

Let us look at a process in which we want to estimate the spectrum of a periodic digital signal  $x(n)$  sampled at a rate of  $f_s$  Hz with the fundamental period  $T_0 = NT$ , as shown in Figure below.

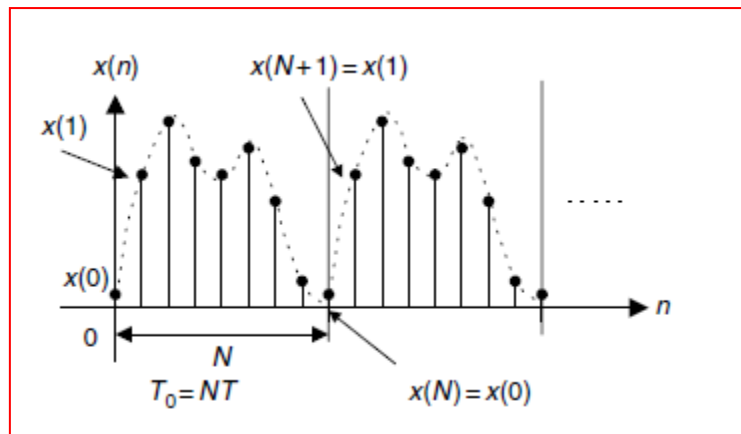

According to Fourier series analysis, the coefficients of the Fourier series expansion of a periodic signal  $x(t)$  in a complex form is

$$c_k = \frac{1}{T_0} \int_{T_0} x(t) e^{-jk\omega_0 t} dt \quad -\infty < k < \infty,$$

where  $k$  is the number of harmonics corresponding to the harmonic frequency of  $kf_0$  and  $\omega_0 = 2\pi / T_0$  and  $f_0 = 1/T_0$  are the fundamental frequency in radians per second and the fundamental frequency in Hz, respectively.

To apply above Equation, we substitute  $T_0 = NT$ ,  $\omega_0 = 2\pi/T_0$  and approximate the integration over one period using a summation by substituting  $dt = T$  and  $t = nT$ . We obtain

$$c_k = \frac{1}{N} \sum_{n=0}^{N-1} x(n) e^{-j\frac{2\pi kn}{N}}, \quad -\infty < k < \infty.$$

Since the coefficients  $c_k$  are obtained from the Fourier series expansion in the complex form, the resultant spectrum  $c_k$  will have two sides. There is an important feature of above Equation in which the Fourier series coefficient  $c_k$  is periodic of  $N$ . We can verify this as follows



$$c_{k+N} = \frac{1}{N} \sum_{n=0}^{N-1} x(n) e^{-j \frac{2\pi(k+N)n}{N}} = \frac{1}{N} \sum_{n=0}^{N-1} x(n) e^{-j \frac{2\pi k n}{N}} e^{-j 2\pi n}.$$

Since  $e^{-j 2\pi n} = \cos(2\pi n) - j \sin(2\pi n) = 1$ , it follows that

$$c_{k+N} = c_k.$$

Therefore, the two-sided line amplitude spectrum  $|c_k|$  is periodic, as shown in Figure below.

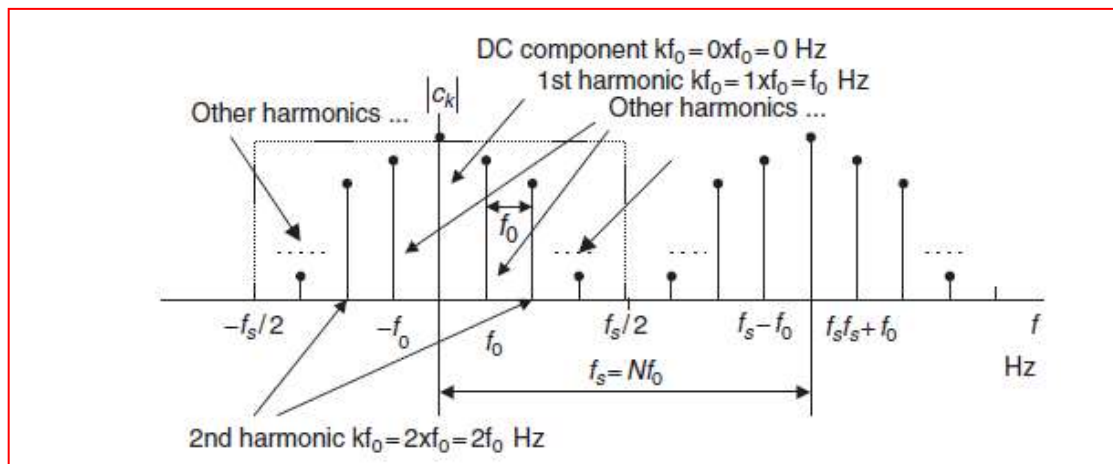

For convenience, we compute the spectrum over the range from 0 to  $f_s$  Hz with nonnegative indices, that is,

$$c_k = \frac{1}{N} \sum_{n=0}^{N-1} x(n) e^{-j \frac{2\pi k n}{N}}, \quad k = 0, 1, \dots, N-1.$$

### Example

The periodic signal

$$x(t) = \sin(2\pi t)$$

is sampled using the rate  $f_s = 4$  Hz.

- Compute the spectrum  $c_k$  using the samples in one period.
- Plot the two-sided amplitude spectrum  $|c_k|$  over the range from -2 to 2 Hz.

**Solution:**

- a. From the analog signal, we can determine the fundamental frequency  $\omega_0 = 2\pi$  radians per second and  $f_0 = \frac{\omega_0}{2\pi} = \frac{2\pi}{2\pi} = 1\text{Hz}$ , and the fundamental period  $T_0 = 1$  second. Since using the sampling interval  $T = 1/f_s = 0.25$  second, we get the sampled signal as

$$x(n) = x(nT) = \sin(2\pi nT) = \sin(0.5\pi n)$$

and plot the first eight samples as shown in Figure

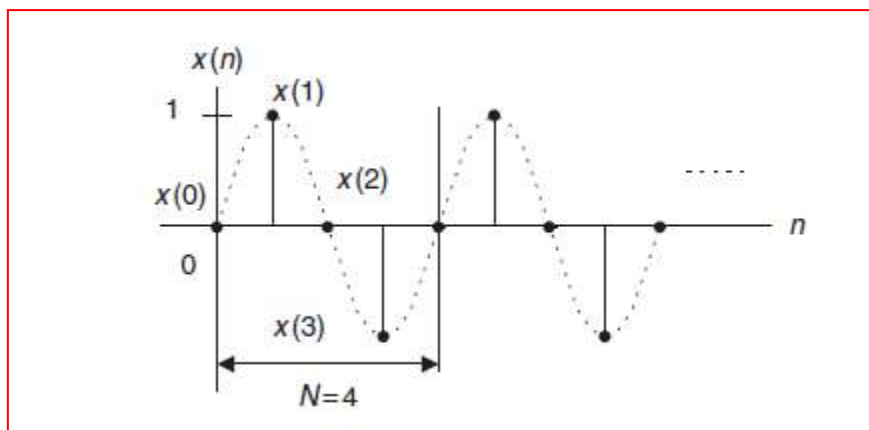

Choosing the duration of one period,  $N = 4$ , we have the sample values as follows

$$x(0) = 0; x(1) = 1; x(2) = 0; \text{ and } x(3) = -1.$$

$$c_0 = \frac{1}{4} \sum_{n=0}^3 x(n) = \frac{1}{4} (x(0) + x(1) + x(2) + x(3)) = \frac{1}{4} (0 + 1 + 0 - 1) = 0$$

$$c_1 = \frac{1}{4} \sum_{n=0}^3 x(n)e^{-j2\pi \times 1n/4} = \frac{1}{4} (x(0) + x(1)e^{-j\pi/2} + x(2)e^{-j\pi} + x(3)e^{-j3\pi/2})$$
$$= \frac{1}{4} (x(0) - jx(1) - x(2) + jx(3)) = 0 - j(1) - 0 + j(-1) = -j0.5.$$

Similarly, we get

$$c_2 = \frac{1}{4} \sum_{k=0}^3 x(n)e^{-j2\pi \times 2n/4} = 0, \text{ and } c_3 = \frac{1}{4} \sum_{n=0}^3 x(k)e^{-j2\pi \times 3n/4} = j0.5.$$

Using periodicity, it follows that

- b. The amplitude spectrum for the digital signal is sketched in Figure

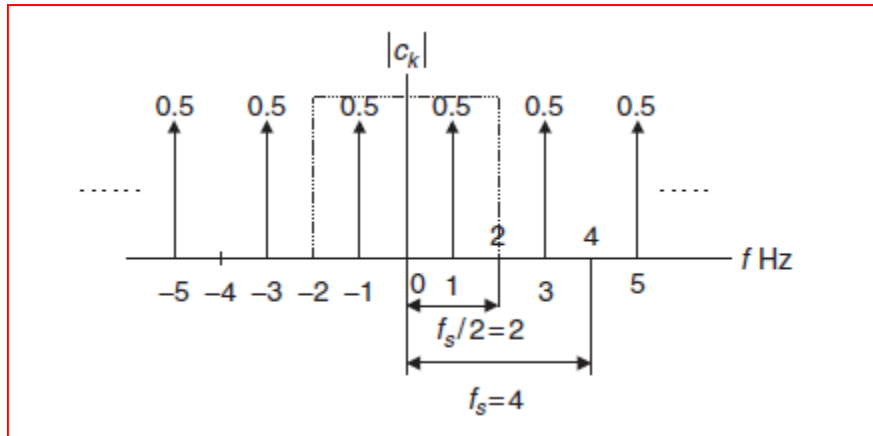

As we know, the spectrum in the range of -2 to 2 Hz presents the information of the sinusoid with a frequency of 1 Hz and a peak value of  $2|c_1| = 1$  which is converted from two sides to one side by doubling the spectral value. Note that we do not double the direct-current (DC) component, that is,  $c_0$ .

### Discrete Fourier Transform Formulas

Now, let us concentrate on development of the DFT. Figure below shows one way to obtain the DFT formula.

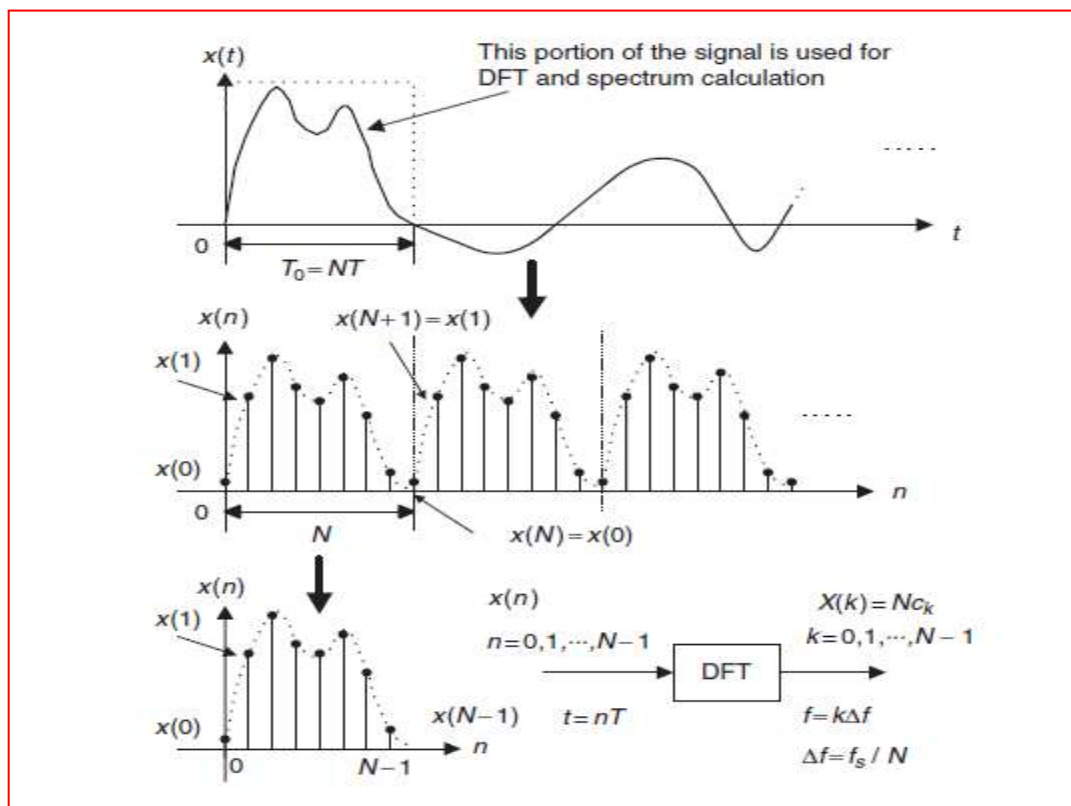

First, we assume that the process acquires data samples from digitizing the interested continuous signal for duration of T seconds. Next, we assume that a

periodic signal  $x(n)$  is obtained by copying the acquired  $N$  data samples with the duration of  $T$  to itself repetitively.

We determine the Fourier series coefficients using one-period  $N$  data samples then we multiply the Fourier series coefficients by a factor of  $N$  to obtain

$$X(k) = Nc_k = \sum_{n=0}^{N-1} x(n)e^{-j\frac{2\pi kn}{N}}, \quad k = 0, 1, \dots, N - 1,$$

Now let us conclude the DFT definition. Given a sequence  $x(n)$ ,  $0 \leq n \leq N - 1$ , its DFT is defined as

$$X(k) = \sum_{n=0}^{N-1} x(n)e^{-j2\pi kn/N} = \sum_{n=0}^{N-1} x(n)W_N^{kn}, \quad \text{for } k = 0, 1, \dots, N - 1.$$

Above equation can be expanded as

$$X(k) = x(0)W_N^{k0} + x(1)W_N^{k1} + x(2)W_N^{k2} + \dots + x(N-1)W_N^{k(N-1)},$$

for  $k = 0, 1, \dots, N - 1$ ,

Where the factor  $W_N$  (called the twiddle factor in some textbooks) is defined as

$$W_N = e^{-j2\pi/N} = \cos\left(\frac{2\pi}{N}\right) - j \sin\left(\frac{2\pi}{N}\right).$$

The inverse DFT is given by

$$x(n) = \frac{1}{N} \sum_{k=0}^{N-1} X(k)e^{j2\pi kn/N} = \frac{1}{N} \sum_{k=0}^{N-1} X(k)W_N^{-kn}, \quad \text{for } n = 0, 1, \dots, N - 1.$$

Similarly

$$x(n) = \frac{1}{N} \left( X(0)W_N^{-0n} + X(1)W_N^{-1n} + X(2)W_N^{-2n} + \dots + X(N-1)W_N^{-(N-1)n} \right),$$

for  $n = 0, 1, \dots, N - 1$ .

### Example

Given a sequence  $x(n)$  for  $0 \leq n \leq 3$ , where  $x(0) = 1$ ,  $x(1) = 2$ ,  $x(2) = 3$ , and  $x(3) = 4$ ,

Evaluate its DFT  $X(k)$ .

**Solution:**

$$X(k) = \sum_{n=0}^3 x(n)W_4^{kn} = \sum_{n=0}^3 x(n)e^{-j\frac{\pi kn}{2}}.$$

Thus, for  $k = 0$

$$\begin{aligned} X(0) &= \sum_{n=0}^3 x(n)e^{-j0} = x(0)e^{-j0} + x(1)e^{-j0} + x(2)e^{-j0} + x(3)e^{-j0} \\ &= x(0) + x(1) + x(2) + x(3) \\ &= 1 + 2 + 3 + 4 = 10 \end{aligned}$$

for  $k = 1$

$$\begin{aligned} X(1) &= \sum_{n=0}^3 x(n)e^{-j\frac{\pi n}{2}} = x(0)e^{-j0} + x(1)e^{-j\frac{\pi}{2}} + x(2)e^{-j\pi} + x(3)e^{-j\frac{3\pi}{2}} \\ &= x(0) - jx(1) - x(2) + jx(3) \\ &= 1 - j2 - 3 + j4 = -2 + j2 \end{aligned}$$

for  $k = 2$

$$\begin{aligned} X(2) &= \sum_{n=0}^3 x(n)e^{-j\pi n} = x(0)e^{-j0} + x(1)e^{-j\pi} + x(2)e^{-j2\pi} + x(3)e^{-j3\pi} \\ &= x(0) - x(1) + x(2) - x(3) \\ &= 1 - 2 + 3 - 4 = -2 \end{aligned}$$

and for  $k = 3$

$$\begin{aligned} X(3) &= \sum_{n=0}^3 x(n)e^{-j\frac{3\pi n}{2}} = x(0)e^{-j0} + x(1)e^{-j\frac{3\pi}{2}} + x(2)e^{-j3\pi} + x(3)e^{-j\frac{9\pi}{2}} \\ &= x(0) + jx(1) - x(2) - jx(3) \\ &= 1 + j2 - 3 - j4 = -2 - j2 \end{aligned}$$

### Example

Using the DFT coefficients  $X(k)$  for  $0 \leq k \leq 3$  computed in previous example Evaluate its inverse DFT to determine the time domain sequence  $x(n)$ .

### Solution:

$$x(n) = \frac{1}{4} \sum_{k=0}^3 X(k) W_4^{-nk} = \frac{1}{4} \sum_{k=0}^3 X(k) e^{j\frac{\pi kn}{2}}.$$

Then for  $n = 0$

$$\begin{aligned} x(0) &= \frac{1}{4} \sum_{k=0}^3 X(k) e^{j0} = \frac{1}{4} (X(0)e^{j0} + X(1)e^{j0} + X(2)e^{j0} + X(3)e^{j0}) \\ &= \frac{1}{4} (10 + (-2 + j2) - 2 + (-2 - j2)) = 1 \end{aligned}$$

for  $n = 1$

$$\begin{aligned} x(1) &= \frac{1}{4} \sum_{k=0}^3 X(k) e^{j\frac{k\pi}{2}} = \frac{1}{4} (X(0)e^{j0} + X(1)e^{j\frac{\pi}{2}} + X(2)e^{j\pi} + X(3)e^{j\frac{3\pi}{2}}) \\ &= \frac{1}{4} (X(0) + jX(1) - X(2) - jX(3)) \\ &= \frac{1}{4} (10 + j(-2 + j2) - (-2) - j(-2 - j2)) = 2 \end{aligned}$$

for  $n = 2$

$$\begin{aligned} x(2) &= \frac{1}{4} \sum_{k=0}^3 X(k) e^{jk\pi} = \frac{1}{4} (X(0)e^{j0} + X(1)e^{j\pi} + X(2)e^{j2\pi} + X(3)e^{j3\pi}) \\ &= \frac{1}{4} (X(0) - X(1) + X(2) - X(3)) \\ &= \frac{1}{4} (10 - (-2 + j2) + (-2) - (-2 - j2)) = 3 \end{aligned}$$

and for  $n = 3$

$$\begin{aligned} x(3) &= \frac{1}{4} \sum_{k=0}^3 X(k) e^{j\frac{3k\pi}{2}} = \frac{1}{4} (X(0)e^{j0} + X(1)e^{j\frac{3\pi}{2}} + X(2)e^{j3\pi} + X(3)e^{j\frac{9\pi}{2}}) \\ &= \frac{1}{4} (X(0) - jX(1) - X(2) + jX(3)) \\ &= \frac{1}{4} (10 - j(-2 + j2) - (-2) + j(-2 - j2)) = 4 \end{aligned}$$

Now we explore the relationship between the frequency bin  $k$  and its associated frequency.

The calculated  $N$  DFT coefficients  $X(k)$  represent the frequency components ranging from 0 Hz (or radians/second) to  $f_s$  Hz (or  $\omega_s$  radians/second), hence we can map the frequency bin  $k$  to its corresponding frequency as follows:

$$\omega = \frac{k\omega_s}{N} \text{ (radians per second),}$$

or in terms of Hz,

$$f = \frac{kf_s}{N} \text{ (Hz),}$$

where  $\omega_s = 2\pi f_s$ .

We can define the frequency resolution as the frequency step between two consecutive DFT coefficients to measure how fine the frequency domain presentation is and achieve

$$\Delta\omega = \frac{\omega_s}{N} \text{ (radians per second),}$$

or in terms of Hz, it follows that

$$\Delta f = \frac{f_s}{N} \text{ (Hz).}$$

### Example

In previous examples, given a sequence  $x(n)$  for  $0 \leq n \leq 3$ , where  $x(0) = 1$ ,  $x(1) = 2$ ,  $x(2) = 3$ , and  $x(3) = 4$ , we have computed four DFT coefficients  $X(k)$  for  $0 \leq k \leq 3$  as  $X(0) = 10$ ,  $X(1) = -2 + j2$ ,  $X(2) = -2$ , and  $X(3) = -2 - j2$ . If the sampling rate is 10 Hz,

- a. Determine the sampling period, time index, and sampling time instant for a digital sample  $x(3)$  in time domain.
- b. Determine the frequency resolution, frequency bin number, and mapped frequency for each of the DFT coefficients  $X(1)$  and  $X(3)$  in frequency domain.



## Solution:

a. In time domain, we have the sampling period calculated as

$$T = 1/f_s = 1/10 = 0.1 \text{ second.}$$

For data  $x(3)$ , the time index is  $n = 3$  and the sampling time instant is determined by

$$t = nT = 3 \cdot 0.1 = 0.3 \text{ second.}$$

b. In frequency domain, since the total number of DFT coefficients is four, the frequency resolution is determined by

$$\Delta f = \frac{f_s}{N} = \frac{10}{4} = 2.5 \text{ Hz.}$$

The frequency bin number for  $X(1)$  should be  $k = 1$  and its corresponding frequency is determined by

$$f = \frac{kf_s}{N} = \frac{1 \times 10}{4} = 2.5 \text{ Hz.}$$

Similarly, for  $X(3)$  and  $k = 3$ ,

$$f = \frac{kf_s}{N} = \frac{3 \times 10}{4} = 7.5 \text{ Hz.}$$

## Amplitude Spectrum and Power Spectrum

One of the DFT applications is transformation of a finite-length digital signal  $x(n)$  into the spectrum in frequency domain.

Figure below demonstrates such an application, where  $A_k$  and  $P_k$  are the computed amplitude spectrum and the power spectrum, respectively, using the DFT coefficients  $X(k)$ .

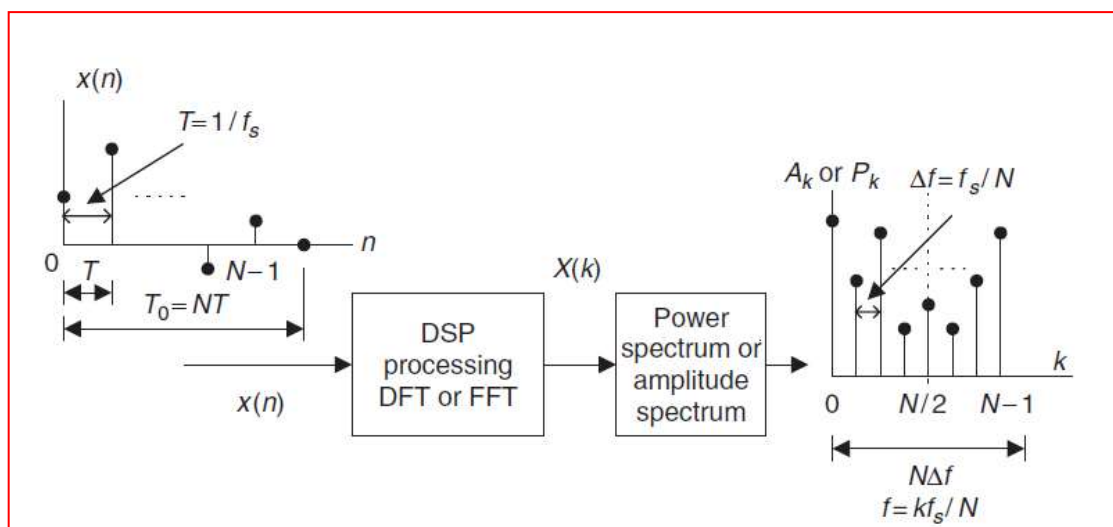

$$A_k = \frac{1}{N} |X(k)| = \frac{1}{N} \sqrt{(\text{Real}[X(k)])^2 + (\text{Imag}[X(k)])^2},$$

$$k = 0, 1, 2, \dots, N - 1.$$

Correspondingly, the phase spectrum is given by

$$\varphi_k = \tan^{-1} \left( \frac{\text{Imag}[X(k)]}{\text{Real}[X(k)]} \right), k = 0, 1, 2, \dots, N - 1.$$

Besides the amplitude spectrum, the power spectrum is also used. The DFT power spectrum is defined as

$$P_k = \frac{1}{N^2} |X(k)|^2 = \frac{1}{N^2} \left\{ (\text{Real}[X(k)])^2 + (\text{Imag}[X(k)])^2 \right\},$$

$$k = 0, 1, 2, \dots, N - 1.$$

### Example

Consider the sequence

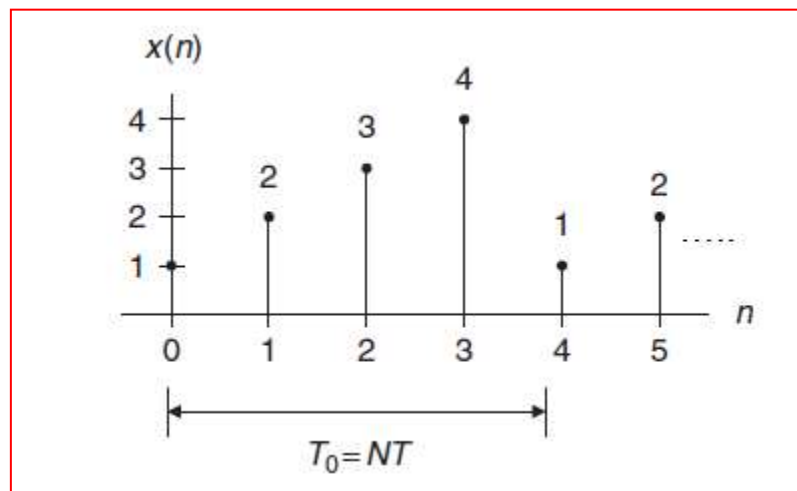

Assuming that  $f_s = 100$  Hz,

Compute the amplitude spectrum, phase spectrum, and power spectrum.

### Solution:

Since  $N = 4$ , and using the DFT, we find the DFT coefficients to be

$$\begin{aligned}
 X(0) &= 10 \\
 X(1) &= -2 + j2 \\
 X(2) &= -2 \\
 X(3) &= -2 - j2.
 \end{aligned}$$

The amplitude spectrum, phase spectrum, and power density spectrum are computed as follows.

For  $k = 0$ ,  $f = k \cdot f_s/N = 0 \times 100/4 = 0$  Hz,

$$A_0 = \frac{1}{4}|X(0)| = 2.5, \varphi_0 = \tan^{-1} \left( \frac{\text{Imag}[X(0)]}{\text{Real}[X(0)]} \right) = 0^\circ,$$

$$P_0 = \frac{1}{4^2}|X(0)|^2 = 6.25.$$

For  $k = 1$ ,  $f = 1 \times 100/4 = 25$  Hz,

$$A_1 = \frac{1}{4}|X(1)| = 0.7071, \varphi_1 = \tan^{-1} \left( \frac{\text{Imag}[X(1)]}{\text{Real}[X(1)]} \right) = 135^\circ,$$

$$P_1 = \frac{1}{4^2}|X(1)|^2 = 0.5000.$$

For  $k = 2$ ,  $f = 2 \times 100/4 = 50$  Hz,

$$A_2 = \frac{1}{4}|X(2)| = 0.5, \varphi_2 = \tan^{-1} \left( \frac{\text{Imag}[X(2)]}{\text{Real}[X(2)]} \right) = 180^\circ,$$

$$P_2 = \frac{1}{4^2}|X(2)|^2 = 0.2500.$$

Similarly, for  $k = 3$ ,  $f = 3 \times 100/4 = 75$  Hz,

$$A_3 = \frac{1}{4}|X(3)| = 0.7071, \varphi_3 = \tan^{-1} \left( \frac{\text{Imag}[X(3)]}{\text{Real}[X(3)]} \right) = -135^\circ,$$

$$P_3 = \frac{1}{4^2}|X(3)|^2 = 0.5000.$$

## 5/ Post test :-

Circle the correct answer:-

**1. Spectral plot displays:**

- a- Time information of digital signals.
- b- Frequency information of digital signal.
- c- Any of the above.
- d- Non of the above.

**2. There is an important feature of the Fourier series coefficient  $c_k$  which is**

- a- Periodic.
- b- Aperiodic.
- c- Any of the above.
- d- Non of the above.

**3- DFT coefficients obtained by:**

- a- Multiplying the Fourier series coefficients by N.
- b- Dividing the Fourier series coefficients by N.
- c- Adding the Fourier series coefficients to N.
- d- Subtracting the Fourier series coefficients from N.

## **6/ key answer :-**

### **1- Pre test :-**

1. a
2. d
3. c

### **2- Post test :-**

1. b
2. a
3. a

## **7/Sources :-**

1. Schaum's Outline of Theory and Problems of Digital Signal processing.
2. Digital signal processing, principles, algorithms, and applications by John G. Proakis and Dimitris G. Manolakis.
3. Signal and systems, Alan Oppenheim.