

HEAT EXCHANGER

PROF. DR. MAJID H. MAJEED

Example 2. Determine a required area for parallel flow heat exchanger for cooling oil from ($60^{\circ}C$) to ($30^{\circ}C$) using water at temperature ($20^{\circ}C$). The water leaves at a temperature ($26^{\circ}C$). The mass flow rate of oil is (10kg/S). The oil has a specific heat of ($2200\text{J/kg}^{\circ}C$). The overall heat transfer coefficient is ($300\text{W}/\text{m}^2^{\circ}C$). compute the area of heat exchanger required and the mass flow rate of cooling water.

Solution: Parallel flow heat exchanger used to cool oil from

$$T_{h1} = 60^{\circ}C \text{ and } T_{h2} = 30^{\circ}C \quad \dot{m}_h = 10\text{kg/sec} \quad C_{p_h} = 2200\text{J/kg}^{\circ}C$$

The cooling fluid is water $T_{c1} = 20^{\circ}C$ and $T_{c2} = 26^{\circ}C$ and the over heat transfer coefficient $U=300\text{W}/\text{m}^2^{\circ}C$.

For water the specific heat is $C_{p_c} = 4200\text{J/kg}^{\circ}C$

Requirement: Area of heat exchanger A , mass flow rate of water m_c .

Analysis: at beginning we will calculate the LMTD for the heat exchanger . The flow is parallel

$$\Delta T_m = \frac{(T_{h1} - T_{c1}) - (T_{h2} - T_{c2})}{\ln\left(\frac{T_{h1} - T_{c1}}{T_{h2} - T_{c2}}\right)} = \frac{(60 - 20) - (30 - 26)}{\ln\left(\frac{60 - 20}{30 - 26}\right)}$$

$$\Delta T_m = 15.635^\circ C$$

▶ To find the area of the heat Exchanger

$$Q = AU\Delta T_m$$

$$Q = \dot{m}_h C p_h (T_{h1} - T_{h2})$$

$$Q = 10 \times 2200(60 - 30) = 660000W$$

$$\text{Then } Q = AU\Delta T_m$$

$$660000 = A \times 300 \times 15.635 \rightarrow A = 140.71m^2$$

Mass flow rate of water

$$Q = \dot{m}_c C p_c (T_{c2} - T_{c1})$$

$$660000 = \dot{m}_c \times 4200(26 - 20) \rightarrow \dot{m}_c = 26.19kg/sec$$

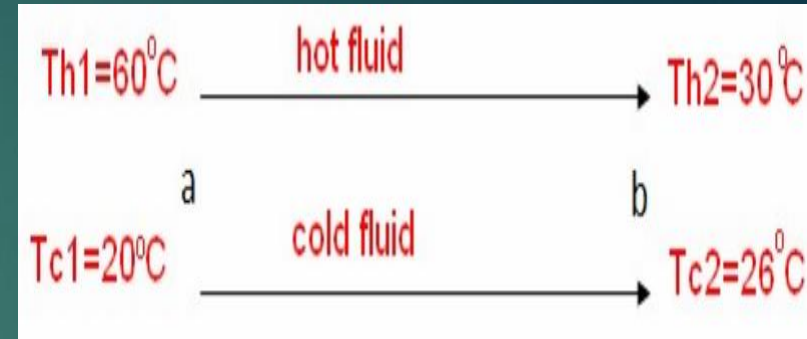

- ▶ **Counter flow heat exchanger:** The log mean temperature difference is calculated for the counter flow as that in the parallel flow heat exchanger but the direction is be oposit as below

$$\Delta T_m = \frac{(\Delta T_a - \Delta T_b)}{\ln\left(\frac{\Delta T_a}{\Delta T_b}\right)} = \frac{(T_{h2} - T_{c1}) - (T_{h1} - T_{c2})}{\ln\left(\frac{T_{h2} - T_{c1}}{T_{h1} - T_{c2}}\right)}$$

- ▶ **Example 3.** Determine a required area for counter flow heat exchanger for cooling oil from (60°C) to (30°C) using water at temperature (20°C). The water leaves at a temperature (25°C). The mass flow rate of oil is ($10\text{kg}/\text{Sec}$). The oil has a specific heat of ($2200\text{J}/\text{kg}\cdot^\circ\text{C}$). The overall heat transfer coefficient is ($300\text{W}/\text{m}^2\cdot^\circ\text{C}$). Compute the area of heat exchanger required and the mass flow rate of the water that used for cooling.

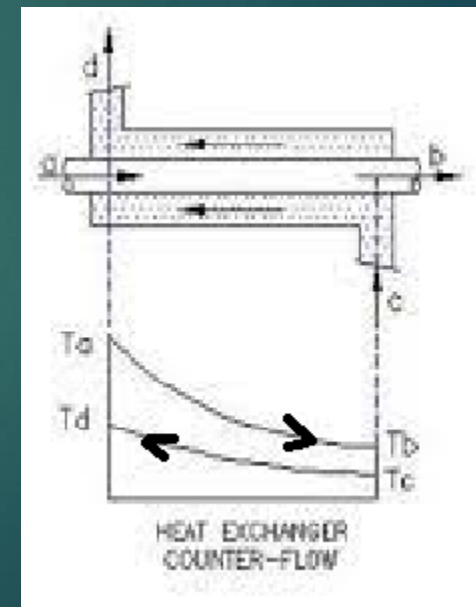
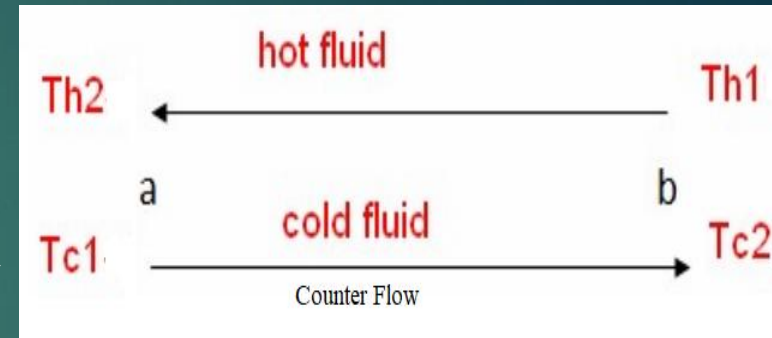

- ▶ Solution: Counter flow heat exchanger is used to cool oil of mass flow rate

$$\dot{m}_h = 10 \text{ kg/sec and } C_{p_h} = 2200 \text{ J/kg} \cdot ^\circ \text{C}$$

$$T_{h1} = 60^\circ \text{C}, \quad T_{h2} = 30^\circ \text{C}$$

- ▶ The water is the cooling fluid of

$$C_{p_c} = 4200 \text{ J/kg} \cdot ^\circ \text{C}, \quad T_{c1} = 20^\circ \text{C} \text{ and}$$

$$T_{c2} = 25^\circ \text{C} \text{ overall coefficient of convection is } U = 300 \text{ W/m}^2 \cdot ^\circ \text{C}.$$

Requirement: The Area of heat exchanger A

And the mass flow rate of water

- ▶ Analysis: The heat transfer is equal to heat losses from oil $Q = \dot{m}_h C_{p_h} (T_{h1} - T_{h2})$

$$Q = 2200 \times 10(60 - 30) = 660000 \text{ W}$$

$$\Delta T_m = \frac{(\Delta T_a - \Delta T_b)}{\ln\left(\frac{\Delta T_a}{\Delta T_b}\right)} = \frac{(T_{h2} - T_{c1}) - (T_{h1} - T_{c2})}{\ln\left(\frac{T_{h2} - T_{c1}}{T_{h1} - T_{c2}}\right)}$$

$$\Delta T_m = \frac{(30 - 20) - (60 - 25)}{\ln\left(\frac{30 - 20}{60 - 25}\right)} = 19.956^\circ \text{C}$$

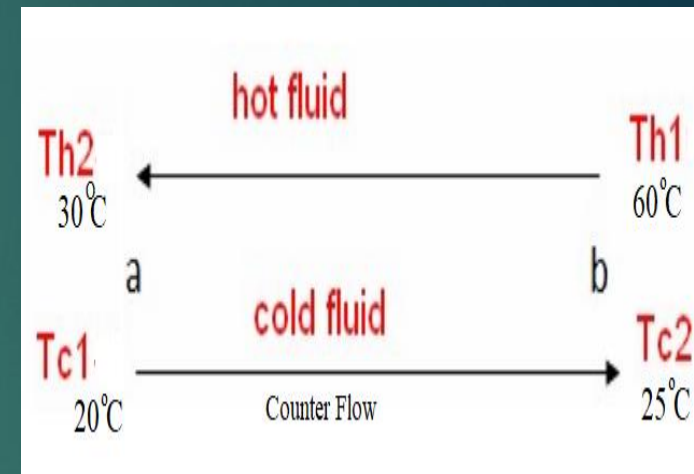

- ▶ The area of heat exchanger
- ▶ $Q = AU\Delta T_m \rightarrow 660000 = A \times 300 \times 19.956 \rightarrow A = 110.24m^2$
- ▶ Mass flow rate of water
- ▶ $Q = \dot{m}_c C p_c (T_{c2} - T_{c1})$
- ▶ $660000 = \dot{m}_c \times 4200(25 - 20) \rightarrow \dot{m}_c = 440kg/sec$
- ▶ Fouling Effect
- ▶ Due to operation some scales be forms on the outer and inner surfaces of tube. This fouling will increase thermal resistance to heat transfer. The fouling resistance for inner and outer surface are denoted as F_i and F_o with units $K.m^2 /W$. The overall heat transfer coefficients can be rewritten as following

Overall heat transfer coefficient based on outer surface

$$\blacktriangleright U_o = \left[\frac{A_o}{A_i h_i} + \frac{A_o F_i}{A_i} + \frac{A_o}{2\pi L k} \ln \frac{r_o}{r_i} + \frac{A_o F_o}{A_o} + \frac{A_o}{A_o h_o} \right]^{-1}$$

$$\blacktriangleright U_o = \left[\frac{r_o}{r_i h_i} + \frac{r_o F_i}{r_i} + \frac{r_o}{k} \ln \frac{r_o}{r_i} + F_o + \frac{1}{h_o} \right]^{-1}$$

Overall heat transfer coefficient based on inner surface

$$U_i = \left[\frac{A_i}{A_i h_i} + \frac{A_i F_i}{A_i} + \frac{A_i}{2\pi L k} \ln \frac{r_o}{r_i} + \frac{A_i F_o}{A_o} + \frac{A_i}{A_o h_o} \right]^{-1}$$

$$U_i = \left[\frac{1}{h_i} + F_i + \frac{r_i}{k} \ln \frac{r_o}{r_i} + \frac{r_i F_o}{r_o} + \frac{r_i}{r_o h_o} \right]^{-1}$$

The fouling can be formed in the following processes

- 1- Fouling of Corrosion,
- 2- Particulate fouling or Sedimentation,
- 3- Biological fouling,
- 4- Fouling of Chemical reaction or polymerization, and
- 5- Precipitation or crystallization fouling

- ▶ The Fouling factor can be tableted in the following table for different cases

FOULING RESISTANCE: F

<i>Type of Fluid</i>	<i>Fouling Resistance F [K.m²/W]</i>
Sea water below 52°C	0.0000877
Sea water above 52°C	0.0001754
Treated feed water of boiler above 52°C	0.0001754
Oil Fuel	0.000877
Oil for quenching	0.0007051
Vapor of alcohol	0.0000877
Steam, non oil bearing	0.0000877
Industrial oil	0.0003525
Refrigerant	0.0001754

- ▶ The parameters affecting fouling are velocity, temperature, fluid chemistry and tubes materials. The methods that keep fouling minimum or prevent it are:
 - 1- heat exchanger design
 - 2-process system treatment and
 - 3- cleaning system use.

▶ **Example 3.** Calculate the overall heat transfer coefficient based on the inside area of a brass tube. The inner and outer diameters of tube are (3.0cm) and (4.0cm) respectively. Thermal conductivity of brass is taken to be ($120\text{W}/\text{m}\cdot^\circ\text{C}$). The heat transfer coefficients on inside and outside surfaces of the tube are ($1600\text{W}/\text{m}^2\cdot^\circ\text{C}$) and ($2800\text{W}/\text{m}^2\cdot^\circ\text{C}$) respectively. The fouling factors for outside and inside surfaces are ($0.00018\text{m}^2\cdot^\circ\text{C}/\text{W}$).

▶ **Solution:** The inner diameter $d_i = 3.0\text{cm}$, $r_i = 0.015\text{m}$

▶ $h_i = 1600\text{W}/\text{m}^2\cdot^\circ\text{C}$, $F_i = 0.00018\text{m}^2\cdot^\circ\text{C}/\text{W}$,

▶ The outer diameter $d_o = 4.0\text{ cm}$, $r_o = 0.02\text{m}$, $h_o = 2800\text{W}/\text{m}^2\cdot^\circ\text{C}$, $F_o = 0.00018\text{m}^2\cdot^\circ\text{C}/\text{W}$. the thermal conductivity of brass which tube material $k=120\text{W}/\text{m}\cdot^\circ\text{C}$

▶ **Requirements:** The overall heat transfer coefficient based on the inside area, U_i .

▶

- ▶ **Analysis:** The overall heat transfer coefficient based on the inner area can be calculated from the following relation.

$$U_i = \left[\frac{1}{h_i} + F_i + \frac{r_i}{k} \ln \frac{r_o}{r_i} + \frac{r_i F_o}{r_o} + \frac{r_i}{r_o h_o} \right]^{-1}$$

$$U_i = \left[\frac{1}{1600} + 0.00018 + \frac{0.015}{120} \ln \frac{2.0}{1.5} + \frac{1.5 \times 0.00018}{2.0} + \frac{1.5}{2.0 \times 2800} \right]^{-1}$$

$$U_i = 804 \text{ W/m}^2 \text{ } ^\circ\text{C}$$

- ▶ By adding extra solution for the U_o where

$$U_o = \left[\frac{r_o}{r_i h_i} + \frac{r_o F_i}{r_i} + \frac{r_o}{k} \ln \frac{r_o}{r_i} + F_o + \frac{1}{h_o} \right]^{-1}$$

$$U_o = \left[\frac{2.0}{1.5 \times 1600} + \frac{2.0 \times 0.00018}{1.5} + \frac{0.02}{120} \ln \frac{2.0}{1.5} + 0.00018 + \frac{1}{2800} \right]^{-1}$$

$$U_o = 603 \text{ W/m}^2 \text{ } ^\circ\text{C}$$

- ▶ Or we calculate A_i and A_o

$$A_i = 2\pi L r_i = \pi L d_i = 3\pi L, \quad A_o = 2\pi L r_o = \pi L d_o = 4\pi L$$

$$U_o = \frac{A_i}{A_o} U_i = \frac{3\pi L}{4\pi L} (804) = 603 \text{ W/m}^2 \text{ } ^\circ\text{C}$$

- ▶ **Example 4:** A thin tube heat exchanger with inside heat coefficient is $(1000\text{W}/\text{m}^2\text{C})$, and outside heat transfer coefficient is $(1800\text{W}/\text{m}^2\text{C})$. Find the overall heat transfer coefficient. The fouling factors are $(0.00021\text{m}^2\text{C}/\text{W})$ and $(0.00022\text{m}^2\text{C}/\text{W})$ for inside and outside surfaces respectively, Find the overall heat transfer coefficient with out fouling effect.

- ▶ **Solution:** Thin tube (for thin thickness tube $d_o \approx d_i$)

- ▶ $h_i = 1000\text{W}/\text{m}^2\text{C}, F_i = 0.00021\text{m}^2\text{C}/\text{W}$

- ▶ $h_o = 1800\text{W}/\text{m}^2\text{C}, F_o = 0.00022\text{m}^2\text{C}/\text{W}$

- ▶ **Requirement:** overall heat transfer coefficient

- ▶ **Analysis:** For tube of thin wall thickness $U = U_i = U_o$

- ▶
$$U = \left[\frac{1}{h_i} + F_i + \frac{r_i}{k} \ln \frac{r}{r} + F_o + \frac{1}{h_o} \right]^{-1}$$

- ▶
$$U = \left[\frac{1}{1000} + 0.00021 + 0 + 0.00022 \right]^{-1}$$

- ▶ For the heat transfer coefficient without fouling effect and the tube is thin

$$\text{▶ } U = \left[\frac{1}{h_i} + \frac{1}{h_o} \right]^{-1} = \left[\frac{1}{1000} + \frac{1}{1800} \right]^{-1} = 642.86 \text{ W/m}^2 \text{ } ^\circ\text{C}$$

- ▶ **Example 5:** The mass flow rates of hot and cold water streams passing through a heat exchanger of parallel flow are (0.25kg/Sec) and (0.5kg/Sec) respectively. The temperature of inlet for the hot and cold streams are (80°C) and (30°C) respectively. The temperature at exit of the hot water is (55°C). If the both sides coefficients heat transfer are ($700\text{W/m}^2\text{ } ^\circ\text{C}$). Calculate the heat exchanger area required.

- ▶ **Solution:** Heat exchanger of parallel flow. The hot side is water $\dot{m}_h = 0.25\text{kg/sec}$, $Cp_h = 4200\text{J/kg.}^\circ\text{C}$, $T_{h1} = 80^\circ\text{C}$, $T_{h2} = 55^\circ\text{C}$. The cold side is water $\dot{m}_c = 0.5\text{kg/sec}$, $Cp_c = 4200\text{J/kg.}^\circ\text{C}$, $T_{c1} = 30^\circ\text{C}$ $h_i = h_o = 700\text{W/m}^2\text{ } ^\circ\text{C}$.

Requirements: The area of heat exchanger

► Analysis: The area of the heat exchanger can be calculated from $Q = AU\Delta T_m$

► Then we first calculate Q, U, and ΔT_m

► $Q = \dot{m}_h C p_h (T_{h1} - T_{h2}) = 0.25 \times 4200(80 - 55) = 26250\text{W}$

► To find $T_{c2} \rightarrow Q = C p_c \dot{m}_c (T_{c2} - T_{c1})$

► $26250 = 4200 \times 0.5(T_{c2} - 30) \rightarrow T_{c2} = 42.5^\circ\text{C}$

►
$$\Delta T_m = \frac{(T_{h1} - T_{c1}) - (T_{h2} - T_{c2})}{\ln\left(\frac{T_{h1} - T_{c1}}{T_{h2} - T_{c2}}\right)} = \frac{(80 - 30) - (55 - 42.5)}{\ln\left(\frac{80 - 30}{55 - 42.5}\right)} = \frac{50 - 12.5}{\ln\frac{50}{12.5}} = 27.0^\circ\text{C}$$

►
$$U = \left[\frac{1}{h_i} + \frac{1}{h_o}\right]^{-1} = \left[\frac{1}{700} + \frac{1}{700}\right]^{-1} = 350\text{W}/\text{m}^2\text{C}$$

► Then $A = \frac{Q}{U \times \Delta T_m} = \frac{26250}{350 \times 27} = 2.778\text{m}^2$

