

Mechanical Testing

Compression Test

Because of the presence of submicroscopic cracks, brittle materials are often weak in tension, as tensile stress tends to propagate those cracks which are oriented perpendicular to the axis of tension. The tensile strengths they exhibit are low and usually vary from sample to sample. These same materials can nevertheless be quite strong in compression. Brittle materials are chiefly used in compression, where their strengths are much higher. A schematic diagram of a typical compression test is shown in figure 2.

Figure 1 shows a comparison of the compressive and tensile strengths of gray cast iron and concrete, both of which are brittle materials.

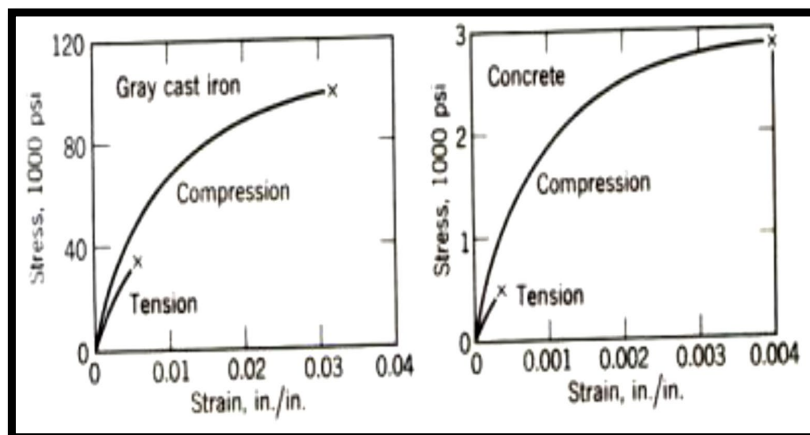

Figure 1. Tensile and compressive engineering stress-strain curves for gray cast iron and concrete.

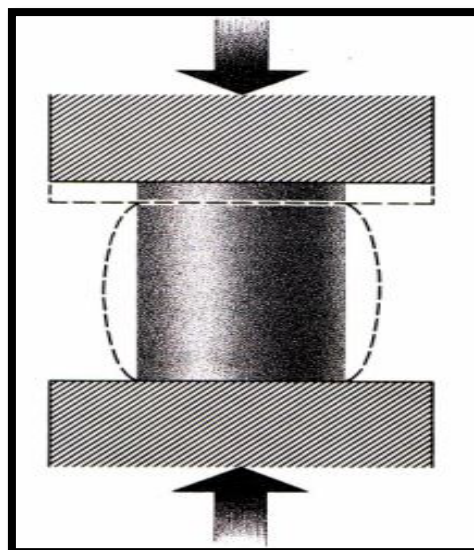

Figure 2. Compression test of ductile material.

Because the compression test increase the cross-sectional area of the sample, necking never occurs. Extremely (majorly), ductile materials are seldom tested in compression because the sample is constrained by friction at the points of contact with the plants of the apparatus. This constraint gives rise to a complicated stress distribution which can only be analyzed in an approximate fashion.