

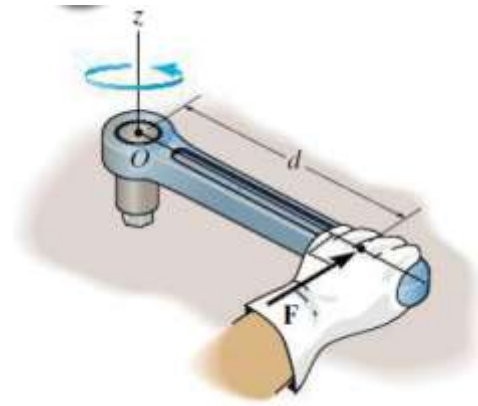

1.3 Moment of a Force

Moment is ability of the force to produce twisting or turning a body about an axis.

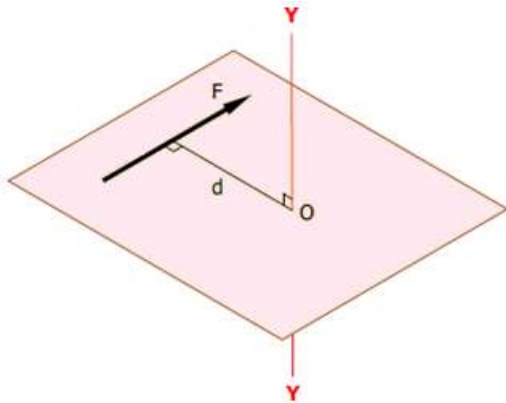

$$M = F \cdot d$$

where:

M: The moment of the force (N.m).

F: Applied force (N).

d: is the perpendicular distance from the axis moment to the line of action of the force.

Units: kN.m, N.m, N.mm (1 kN = 1000 N)

Sign Convention:

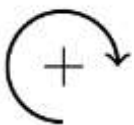

we will be taking clockwise as positive moment

Principle of moments:

The moment of a force with respect to any axis (or point) is equal to the algebraic sum of the moments of its components with respect to the same axis.

$$M = \sum F \cdot d$$

For Example: moment about point O

$$\curvearrowright M_O = \sum F \cdot d$$

$$M_O = F_{1x} \cdot y_1 - F_{1y} \cdot x_1 + F_{2x} \cdot y_2 + F_{3y} \cdot x_3$$

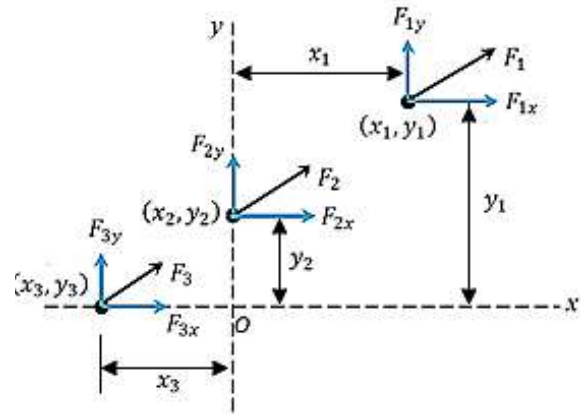

Example No. 1: Calculate the magnitude of the moment about the base point O of the 600-N force.

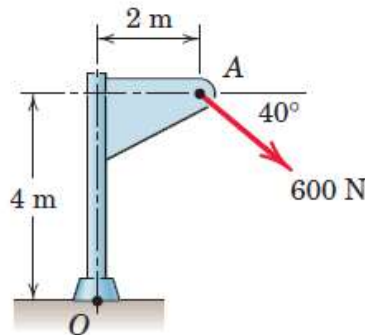

Solution:

$$F_x = 600 \cos 40 = 460 \text{ N} \rightarrow$$

$$F_y = 600 \sin 40 = 386 \text{ N} \downarrow$$

$$\curvearrowright M_O = \sum F \cdot d$$

$$M_O = 460 \times 4 + 386 \times 2 = 2610 \text{ N.m} \curvearrowright$$

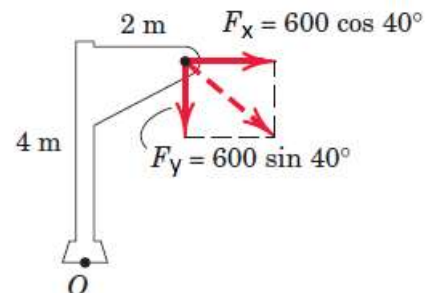

Example No. 2: Compute the moment of a 100 N force applied on a cantilever beam about the fixed end A as shown in Figure.

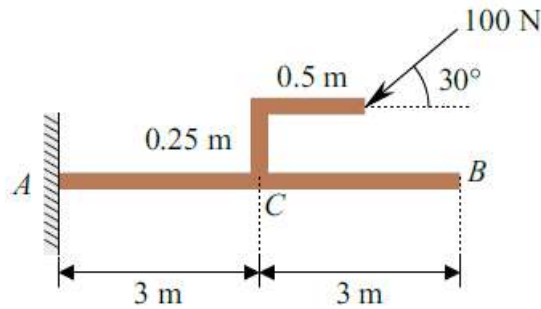

Solution:

Resolving the force along x and y directions.

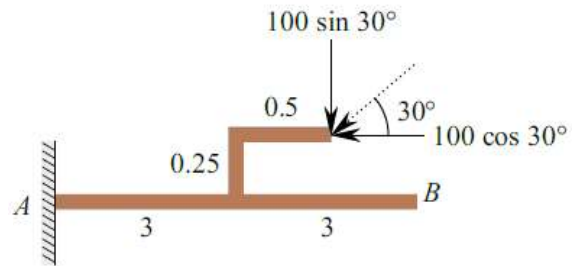

$$\curvearrowright M_A = \sum F \cdot d$$

$$M_A = 100 \sin 30 \times (3 + 0.5) - 100 \cos 30 \times 0.25$$

$$M_A = 153.35 \text{ N.m} \quad \curvearrowright$$

Example No. 3: If the resultant moment about point A is (480 N.m) clockwise. Determine the magnitude of F_3 ?

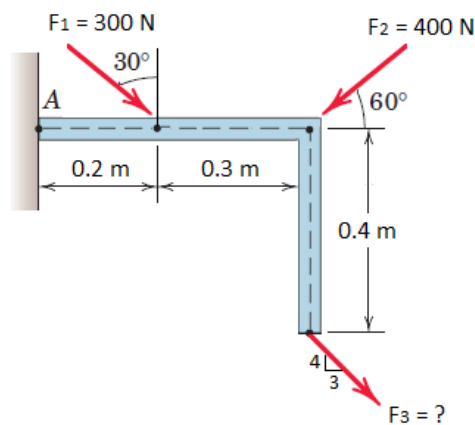

Solution:

$$F_{1x} = 300 \sin 30 = 150 \text{ N} \rightarrow$$

$$F_{1y} = 300 \cos 30 = 259.88 \text{ N} \downarrow$$

$$F_{2x} = 400 \times \cos 60 = 200 \text{ N} \leftarrow$$

$$F_{2y} = 400 \times \sin 60 = 346.41 \text{ N} \downarrow$$

$$c = \sqrt{3^2 + 4^2} = 5$$

$$F_{3x} = F_3 \times \frac{3}{5} = 0.6 F_3 \text{ N} \rightarrow$$

$$F_{3y} = F_3 \times \frac{4}{5} = 0.8 F_3 \text{ N} \downarrow$$

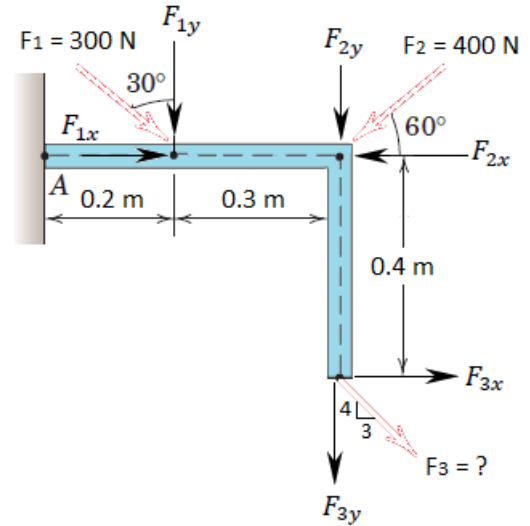

$$\sum M_A = \sum F \cdot d$$

$$480 = F_{1y} \times 0.2 + F_{2y} \times 0.5 - F_{3x} \times 0.4 + F_{3y} \times 0.5$$

$$480 = 259.88 \times 0.2 + 346.41 \times 0.5 - 0.6 F_3 \times 0.4 + 0.8 F_3 \times 0.5$$

$$F_3 = \frac{480 - 225.167}{0.16} = 159.27 \text{ N} \searrow$$

Problems:

1. Determine the moment of the force about O in each case.

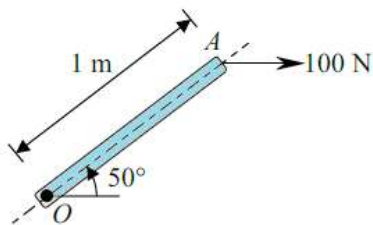

(a)

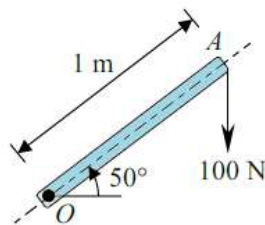

(b)

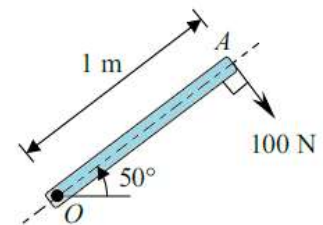

(c)

Answer: (a) $M_O = 76.6 \text{ N.m}$ \curvearrowright , (b) $M_O = 64.3 \text{ N.m}$ \curvearrowright , (c) $M_O = 100 \text{ N.m}$ \curvearrowright

2. Compute the moment of a 200 N force applied as shown in Figure, about points A and B.

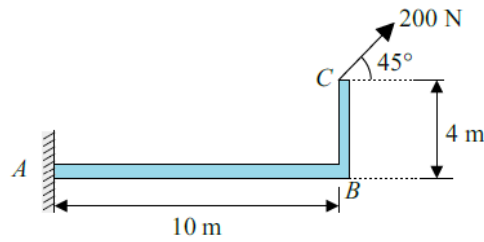

Answer: $M_A = 848.528 \text{ N.m}$ \curvearrowright , $M_B = 565.685 \text{ N.m}$ \curvearrowright

3. Determine the resultant moment produced by the forces about point O.

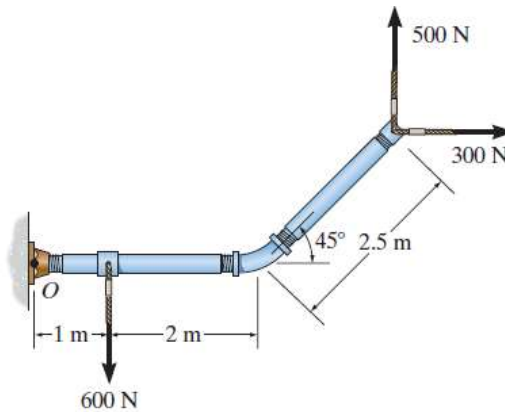

Answer: $M_O = 1253.55 \text{ N.m}$ \curvearrowright

4. Determine the moment of the forces about O.

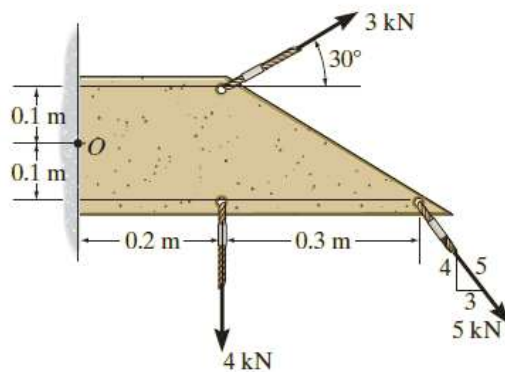

Answer: $M_O = 2.460 \text{ kN.m}$ \curvearrowright