

Republic of Iraq

Ministry of Higher Education & Scientific Research

Al-Mustaqbal University College

Department of Building & Construction Engineering



## “ESTIMATION & SPECIFICATIONS & CONTRACTS” 4<sup>th</sup> Stage

((تدعيم المنشآت الخرسانية))



Prepared by Dr. Abdulhadi Meteab Hasan

## ملحق رقم 1 : تدعيم المنشآت الخرسانية

عام: هذا الملحق خاص بالمهندسين الانشائيين اللذين يعملون في هذا المجال لمدة لا تقل عن خمس سنوات وهو يساعدهم في أعداد التقارير الهندسية باللغة الانكليزية لتحديد المشاكل في المنشآت الخرسانية وكذلك الاشراف على عملية الترميم بشكل جيد ليعطي الديمومة المقبولة للعضو الانشائي المراد ترميمه أو أستبداله ، وتم جمع وتنقيح هذا الملحق من أكثر من مصدر هندسي متخصص في أعمال الترميم ليتلائم مع نوعية الاعمال المدنية في العراق والوطن العربي وحسب المواصفات القياسية الامريكية.

### i. Strengthening of reinforced concrete columns

Strengthening of reinforced concrete columns is needed when:

1. The load carried by the column is increased due to either increasing the number of floors or due to mistakes in the design.
2. The compressive strength of the concrete or the percent and type of reinforcement are not according to the codes' requirements.
3. The inclination of the column is more than the allowable.
4. The settlement in the foundation is more than the allowable.

There are two major techniques for strengthening reinforced concrete columns:

#### 1- Reinforced Concrete Jacket

The size of the jacket and the number and diameter of the steel bars used in the jacketing process depend on the structural analysis that was made to the column. In some cases, before this technique is carried out, we

need to reduce or even eliminate temporarily the loads applied to the column; this is done by the following steps:

Putting mechanical jacks between floors.

Putting additional props between floors.

Moreover, in some cases, where corrosion in the reinforcement steel bars was found, the following steps should be carried out:

Remove the concrete cover.

Clean the steel bars using a wire brush or sand compressor.

Coat the steel bars with an epoxy material that would prevent corrosion.

If there was no need for the previous steps, the jacketing process could start by the following steps:

- Adding steel connectors into the existing column in order to fasten the new stirrups of the jacket in both the vertical and horizontal directions at spaces not more than 50cm. Those connectors are added into the column by making holes 3-4mm larger than the diameter of the used steel connectors and 10-15cm depth.
- Filling the holes with an appropriate epoxy material then inserting the connectors into the holes.
- Adding vertical steel connectors to fasten the vertical steel bars of the jacket following the same procedure in step 1 and 2.
- Installing the new vertical steel bars and stirrups of the jacket according to the designed dimensions and diameters.
- Coating the existing column with an appropriate epoxy material that would guarantee the bond between the old and new concrete.

- Pouring the concrete of the jacket before the epoxy material dries. The concrete used should be of low shrinkage and consists of small aggregates, sand, cement and additional materials to prevent shrinkage.

The previous steps are illustrated in Figure(50)

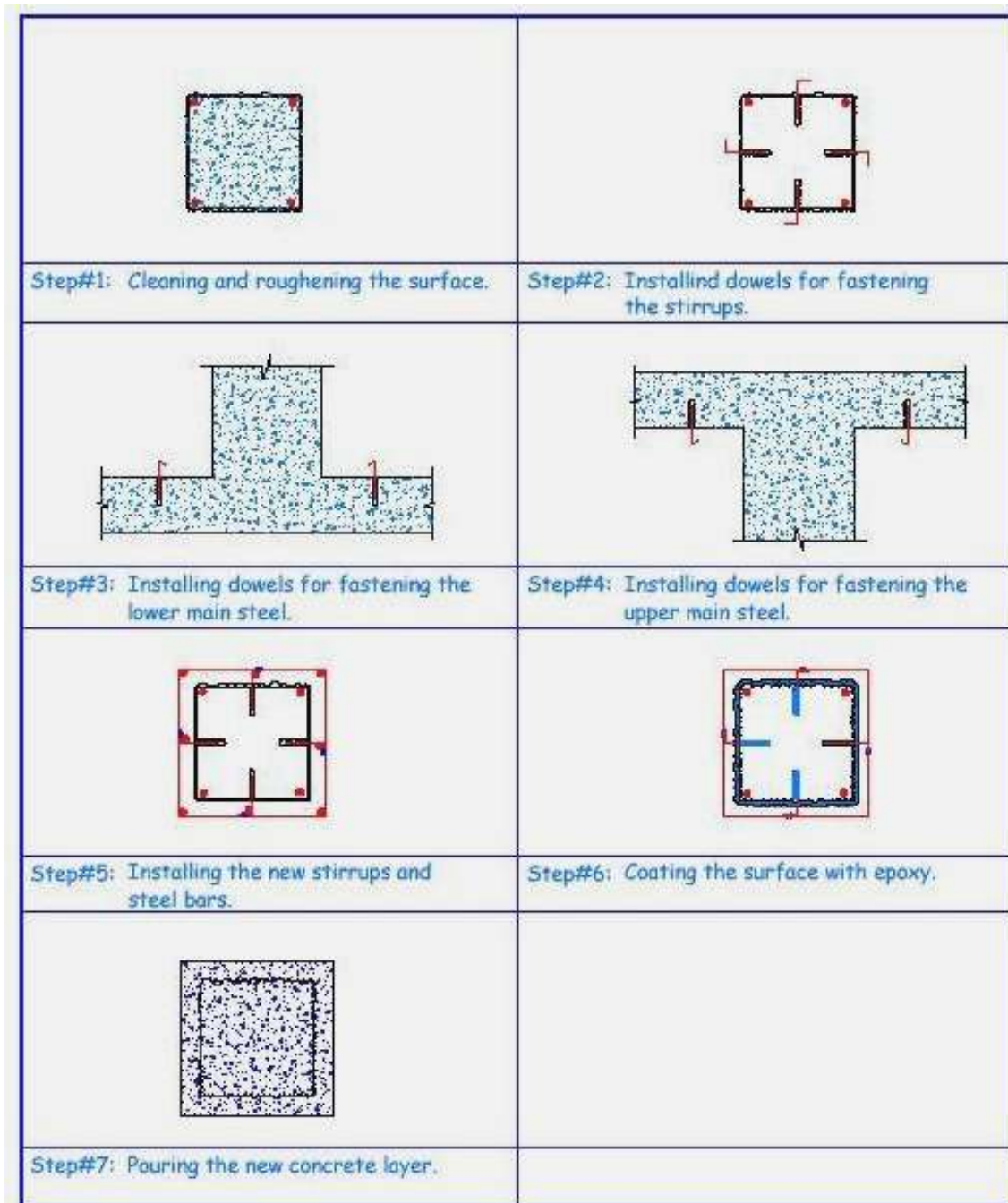

Figure (50): Increasing the cross-sectional area of column by RC jacketing.

## **2- STEEL JACKET**

This technique is chosen when the loads applied to the column will be increased, and at the same time, increasing the cross sectional area of the column is not permitted.

This technique is implemented by the following steps as shown in Fig 2:

1. Removing the concrete cover.
2. Cleaning the reinforcement steel bars using a wire brush or a sand compressor.
3. Coating the steel bars with an epoxy material that would prevent corrosion.
4. Installing the steel jacket with the required size and thickness, according to the design, and making openings to pour through them the epoxy material that would guarantee the needed bond between the concrete column and the steel jacket.
5. Filling the space between the concrete column and the steel jacket with an appropriate epoxy material.



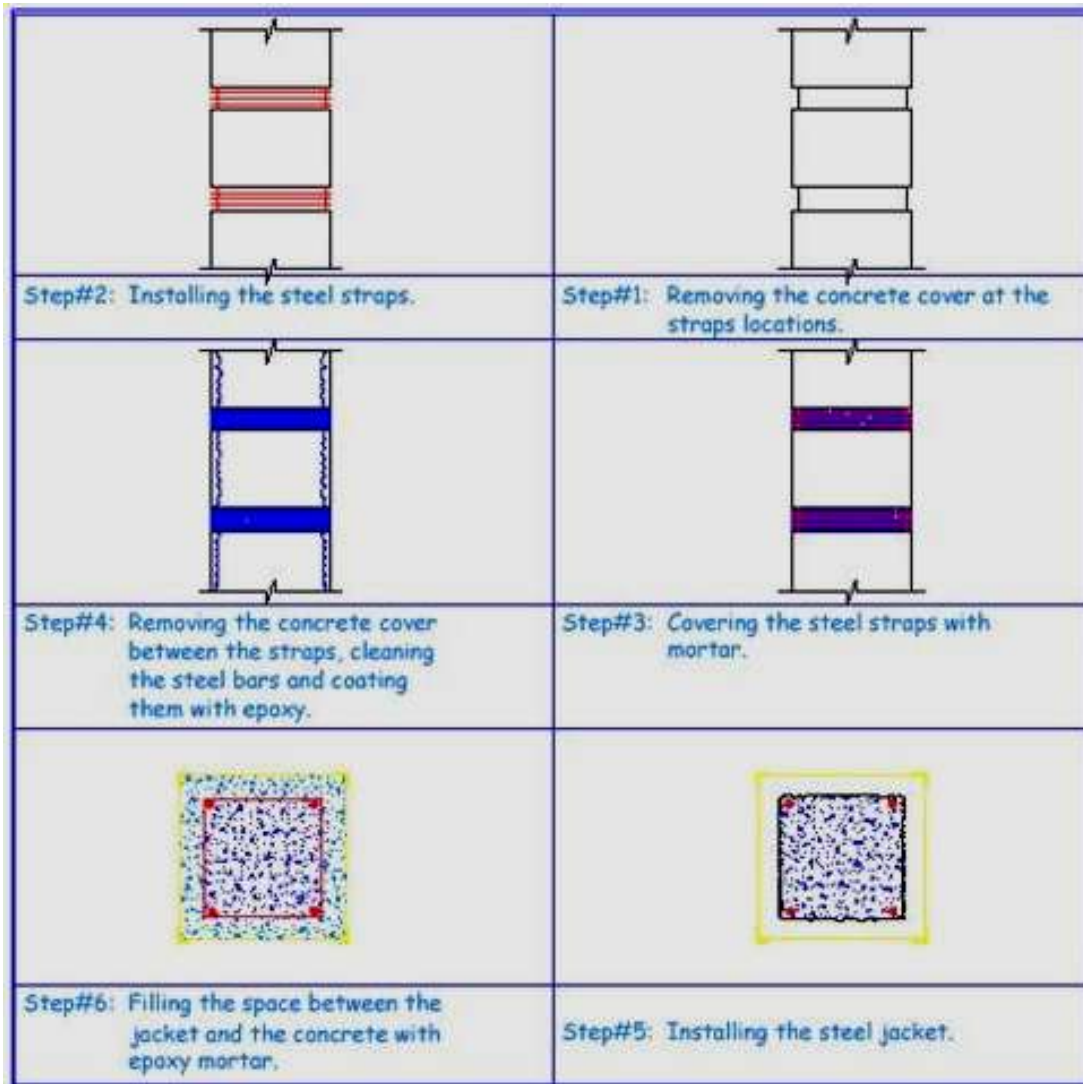

Figure (51): Increasing the cross-sectional area of column by steel jacketing.

In some cases, where the column is needed to carry bending moment and transfer it successfully through the floors, one should install a steel collar at the neck of the column by means of bolts or a suitable bonding material.



Pic. (29): shows a column which was strengthened with steel angles.

## ii. Methods Of Increasing Structural Stiffness

The methods of increasing structural stiffness of tall buildings are by providing central core, shear walls, tubes, braced frame and double tube. These are discussed in detail below.

### 1. Central Core:

By constructing a central core, the stiffness of the building is greatly increased. A central core is used to house stairs and lifts and building services. This method allows the building to keep an open facade. Following figure shows the central core of a building with a 5×5 column.

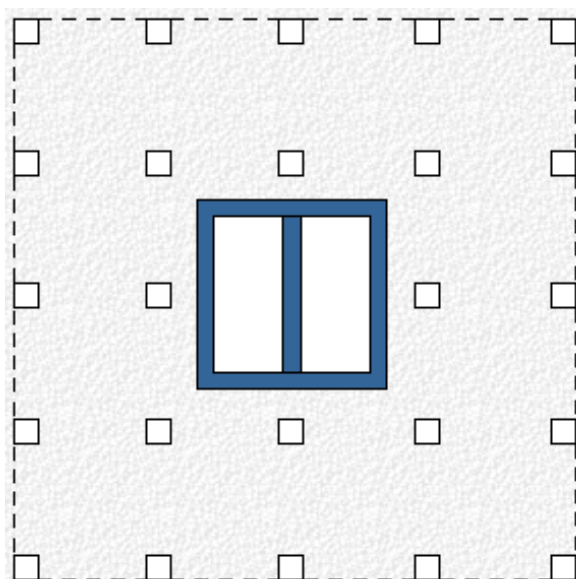

Figure (52):Central core in building

## 2. Shear Walls:

Shear walls are constructed at opposite ends of a building to provide stiffness in a particular direction. Shear walls are particularly useful in non-square buildings, where the wind forces predominantly come from one direction. The interior of the building is kept clear. Shear walls only provide minimal torsional stiffness.

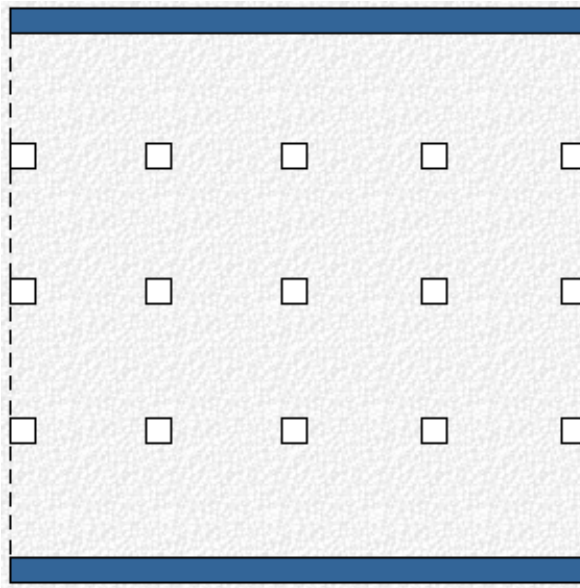

Figure (53): Shear wall

## 3. Tube system:

A tube system is essentially two sets of shear walls. The tube system allows the building to be stiff in all directions of loading. The building will also have a high-torsional resistance. The interior of the building is kept clear.



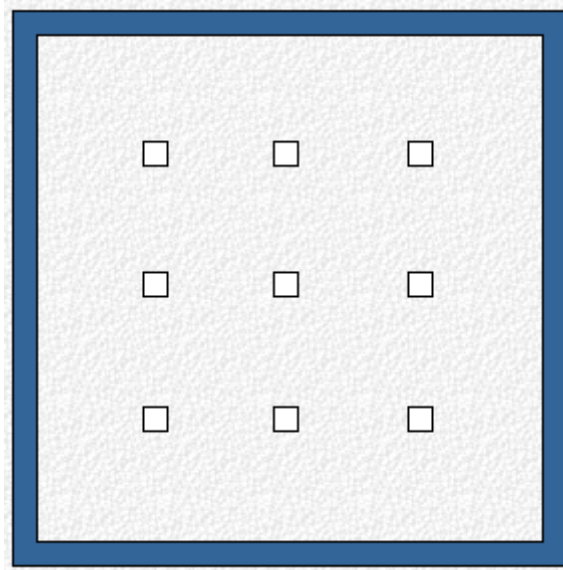

Figure (54): Tube system

The tube system must be pierced for windows. These openings must be kept to minimum.

#### 4. Braced Frame:

Braced frame is the simple structure with bracing that help to increase the structural stiffness. A braced frame is similar to floor bracing, but it does not depend on the stiffness provided by the floor system, rather on the addition of another diagonal cross members.

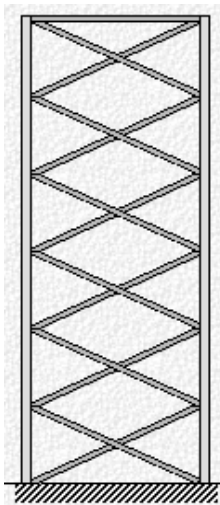

Figure (55): Braced Frame

This type of bracing is lighter than its counterpart with floor bracing. The building has good stiffness.

Compared to the system with floor bracing, this system is less easy to construct. The façade detailing can be interesting but also expensive.

### **5. Double Tube System:**

A double tube system is a combination of the central core and tube system as shown in figure below. This combination of both systems allows the building to be extremely stiff.

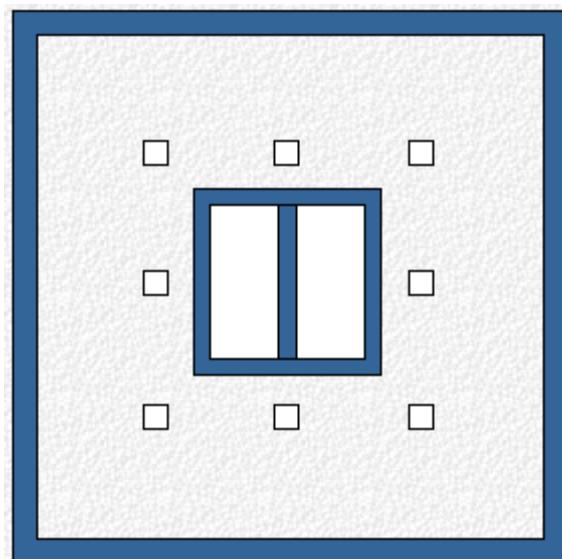

Figure (56): Double Tube System

The building has high torsional resistance. For the tube system, apertures for windows must be kept to minimum. The central core take much valuable space. This type of system is used for very tall building.

### **iii. Methods Of Concrete Column Repair**



Pic. (30): Weak column

Before starting the repair of a column, the axial dead load, axial live load, horizontal load and its associated moments must be known. Repairs to concrete columns can be divided into two categories. Surface or cosmetic repair only covers local deterioration and structural repair restores or strengthens the affected columns. If the deterioration does not significantly reduce the cross section, the conventional concrete repair can successfully be employed.

- Columns may be repaired by using one or more of the following methods:
- Encasement or enlargement of the column cross section (jacketing).
- Cathodic protection to stop reinforcing steel corrosion.
- Realkalization of the reinforcing steel to stop corrosion.
- Chloride extraction to retard the reinforcing steel corrosion.
- Confinement using steel plate, carbon, or glass fiber materials.
- Addition of shear collars to increase the shear capacity of intermediate floors.
- Addition of a steel plate assembly to increase moment capacity.

Supplemental columns.

The application of a protection system to prevent future corrosion.

Following parameters are important for the design and the execution of the column repair:

Unloading columns

In those cases where the column deterioration is significant, unloading the column is usually required so that the entire cross section of the repaired column is capable of carrying the reintroduced design load. Without this unloading, the new repair will hardly carry any load. Drying shrinkage of new material may further reduce this share of load. Unfortunately, it can be difficult and expensive to unload columns, especially in high-rise buildings. If the existing load on a column is not removed before the repair, the jacket will only provide confinement to the existing column. The percentage of direct load taken by jacket will be very small (less than 25 percent of the jacket strength). If it is not possible to remove the load from the column, then a supplemental column system can provide an alternative method of support in combination with the repair of the existing column.

Redistribution of the load

In case of corrosion of reinforcement and significant concrete deterioration, the load is redistributed in the structure before repair to a new pattern which must be considered while designing the repair. Even the adjoining members may have been affected by this redistribution.

Supplemental reinforcing steel

The column ties can not usually be disturbed during the repair as it may cause buckling of the longitudinal bars. Hence, the supplemental vertical bars may be placed outside the original cage with extra ties. When the supplemental bars are placed outside the tie bars, the column dimensions should be increased to provide adequate cover. Hairpin ties, usually of stainless steel, are used to laterally support the supplemental bars.

#### Concrete removal

The removal of concrete within a column cage must only be done if the column is unloaded. Otherwise, the longitudinal bars may buckle and compression failure of column may take place.

#### Corroded reinforcing steel

It is not necessary to remove the corroded reinforcing bar with reduced cross-sectional area if the loss is supplemented with additional reinforcing bars. The lap length of such a splice must be provided corresponding to the area lost by corrosion to either side of the corroded portion of the reinforcing bar that is supplemented. The partially corroded reinforcing bars that are left in place must be thoroughly cleaned by sandblasting to obtain bare metal. The bars with excessive corrosion must be replaced with fresh reinforcement having full laps on both sides.

#### Corroded ties

The corroded ties can be replaced by adding stainless steel hairpin ties that are anchored into the concrete. It is often necessary to deposit extra material around columns to provide adequate cover over the supplemental ties.

#### Low-strength concrete

Where the concrete strength is low, resulting in insufficient load-carrying capacity, several alternatives are available:

- Shore the column and remove and replace the in-place concrete.
- Shore the column and increase the size of the column to reduce the bending stresses, and to increase the confinement on already placed weak concrete.
- Wrap the column with carbon- or glass-reinforced plastic.
- Install a supplemental column.

#### **iv. Repair Of Active Cracks In Concrete**

Methods of Repairing Active Cracks in concrete structures:

##### **1. Drilling and Plugging through Crack:**

One of the approximate methods would be to drill holes normal to cracks, fill them with a suitable epoxy or epoxy-mortar formulation and then place reinforcement bars (of predetermined sizes and lengths) in them to stitch across the cracks. The bars may be placed in the clean holes prior to filling the epoxy (so as to save loss of epoxy) but then great care is needed not to entrap any air.

##### **2. Stitching of Concrete Cracks:**

Stitching involves drilling holes on both sides of the crack and grouting in U-shaped metal units with short legs (staples or stitching dogs) that span the crack as shown in picture (57) below:



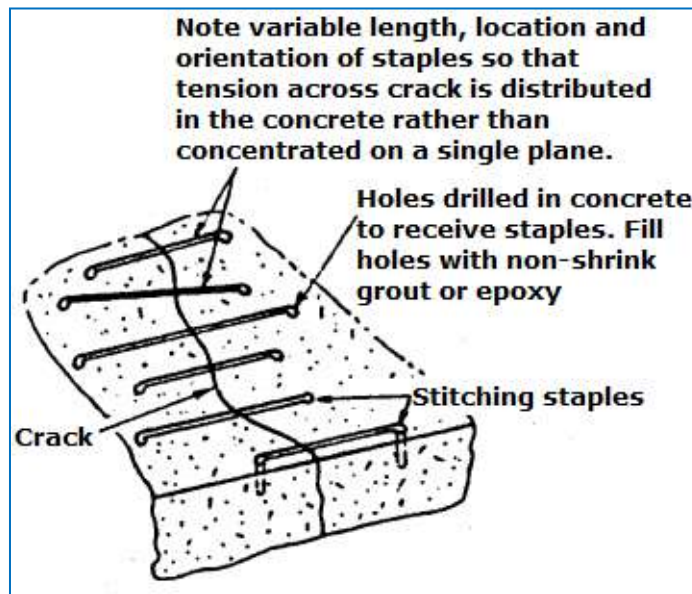

Figure (57): Stitching of concrete cracks

Stitching should be used when tensile strength has to be restored back across major cracks. Stitching a crack tends to stiffen the structure and the stiffening may increase the overall structural restraint, causing the concrete to crack elsewhere. Therefore, it is necessary that proper investigation is done and if required, adjacent section or sections are strengthened using technically designed reinforcing methods. Because stresses are often concentrated, using this method in conjunction with other methods maybe necessary.

The procedure consists of drilling holes on both sides of the crack, cleaning the holes and anchoring the legs of the staples in the holes, with either a non-shrink cement grout or any epoxy resin-based bonding system. The staples should be variable in length, orientation, or both and they should be located so that the tension transmitted across the crack is not applied to a single plane within the section but is spread over an area.

### 3. External Prestressing:

The flexural cracks in reinforced concrete can be arrested and even corrected by the ‘Post –tensioning’ method. It closes the cracks by providing compression force to compensate for tensions and adds a residual compression force. This method requires anchorage of the tie-rods (or wires) to the anchoring device (the guide – bracket-angles) attached to the beam (Fig. 58).

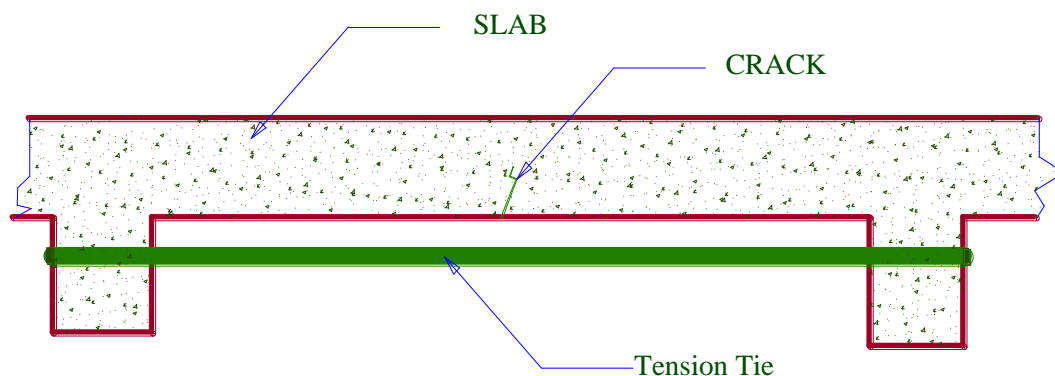

Figure (58): Post Tensioning Cracked Beam

The rods or wires are then tensioned by tightening the end-nuts or by turning of turnbuckles in the rods against the anchoring devices. However, it may become necessary in certain critical case to run at least an approximate stress-check to guard against any possible adverse effects.

#### 4. Drilling and Plugging:

When cracks run in reasonable straight lines and are accessible at one end, drilling down the length of the crack and grouting it to form a key as shown in Figure (59) could repair them.

Form key with precast concrete or mortar plugs set in bitumen. The bitumen is to break the bond between plugs and hole so that plugs will not be cracked by subsequent movement of the opening. If a

particularly good seal is required, drill a second hole and plug with bitumen alone, using the first hole as a key and the second as a seal.

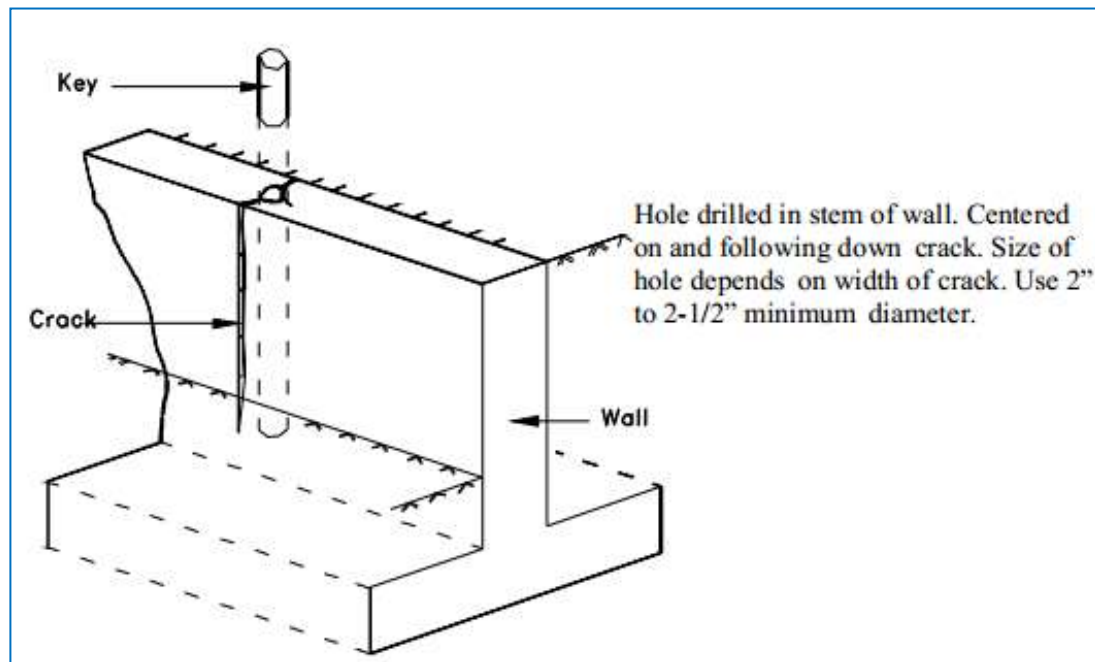

Figure (59): Drilling and Plugging

A hole of 50 to 75mm dia depending on width of crack should be drilled, centered on and following the crack. The hole must be large enough to intersect the crack along its full length and provide enough repair material to structurally take the loads exerted on the key. The drilled hole should then be cleaned, made tight and filled with grout. The grout key prevents transverse movements of the sections of concrete adjacent to the crack.

The key will also reduce heavy leakage through the crack and loss of soil from behind a leaking wall. If water tightness is essential and structural load transfer is not, the drilled hole should be filled with a resilient material of low modulus in lieu of grout. If the key effect is essential, the resilient material can be placed in a second hole, the first being grouted.