

Al-Mustaqbal University College Biomedical Engineering Department



Subject: Biomedical Instrumentation Design.

Class (code): 4th (BME416)

Lecture: 2

BME416

Biomedical Instrumentation Design

- > **Direct and indirect Modes.**
- > Frequently, the measurand can be interfaced directly to a sensor because the measurand is readily available or because suitable invasive techniques are presented.
- > When the desired measurand is unavailable, we can use either an alternative measurand that tolerates a known relation to the desired one or some form of energy or material that interrelates with the desired measurand to create a measurand that is accessible.
- > Examples: cardiac output (volume of blood pump per minute from the heart);
- > morphology of internal organs, determined from x-ray shadows

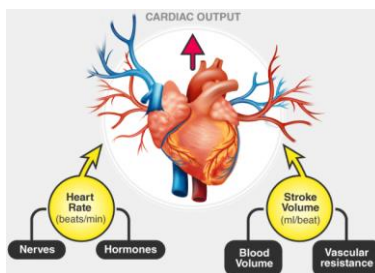

CARDIAC OUTPUT The amount of blood pumped by each ventricle in 1 minute	=	HEART RATE The number of contractions of the ventricles each minute	X	STROKE VOLUME The amount of blood ejected from each ventricle with each contraction
-----------------------------------------------------------------------------------	---	-------------------------------------------------------------------------------	---	-----------------------------------------------------------------------------------------------

AVERAGE 4000 – 5000 ml	=	70	X	70 ml
----------------------------------	---	----	---	-------

Factors affecting Cardiac Output	=	Sympathetic nervous system Epinephrine	X	Venous return (preload) Blood Volume Sympathetic nervous system (contractility) Peripheral resistance (afterload)
-----------------------------------------	---	-------------------------------------------	---	----------------------------------------------------------------------------------------------------------------------------

2

Biomedical Instrumentation Design

> **Sampling and continuous modes**

- > The frequency content of the measurand, the objective of the measurements, the patient's state, and the physician's potential responsibility all guide how often medical data are requisite..
- > Some measurand, like body temperature variate so slowly that may be sampled rarely.
- > Other measures, like ECG, may need continuous observation.

3

Biomedical Instrumentation Design

> **Generating and modulating sensors:**

- > Generating sensors produce their signal output from the energy taken straightly from the measurand itself, like piezoelectric sensors.
- > Modulating sensors, the measurand modulates the flow of energy from an external source in a means that affects the output of the sensor, like the IR sensor.
- > The photovoltaic cell is a generating sensor because it delivers an output voltage correlated to its irradiation, without any other external energy source.
- > The photoconductive cell is a modulating sensor to measure its change in resistance with irradiation, we must apply external energy to the sensor.

> **Presentation!!!**

4

Biomedical Instrumentation Design

> Real and Delayed Timed Modes:

- > Sensors must obtain signals in real-time as the signals really occur.
- > The output of the measurement system may not display the result immediately, though, because some types of signal processing, such as averaging and transformations, need significant input before any results can be produced.
- > Often, such short delays are suitable unless urgent feedback and control tasks depend on the output.
- > In the case of some measurements, such as cell cultures, several days may be required before an output is obtained.

5

Biomedical Instrumentation Design

> Medical Instrumentation Constraints.

- > Nearly all biomedical measurements depend either on some form of energy being applied to the living tissue or on some energy being applied as an incidental consequence of sensor operation.
- > X-ray and ultrasonic imaging techniques and electromagnetic or Doppler ultrasonic blood flowmeters depend on externally applied energy interacting with living tissue.
- > Safe levels of these various types of energy are difficult to establish because many mechanisms of tissue damage are not well understood.

6

Biomedical Instrumentation Design

> Medical Instrumentation Constraints.

- > A fetus is particularly vulnerable during the early stages of development. The heating of tissue is one effect that must be limited because even reversible physiological changes can affect measurements. Damage to tissue at the molecular level has been demonstrated in some instances at surprisingly low energy levels.
- > The operation of instruments in the medical environment imposes important additional constraints. Equipment must be reliable, easy to operate, and capable of withstanding physical abuse and exposure to corrosive chemicals.
- > Electronic equipment must be designed to minimize electric-shock hazards.
- > The safety of patients and medical personnel must be considered in all phases of the design and testing of instruments.

7

Biomedical Instrumentation Design

> Classification of Biomedical Instruments:

- > The quantity that is sensed, such as pressure, flow, or temperature. One advantage of this classification is that it makes different methods for measuring any quantity easy to compare.
- > The principle of transduction, such as resistive, inductive, capacitive, ultrasonic, or electrochemical. Different applications of each principle can be used to strengthen understanding of each concept; also, new applications may be readily apparent.
- > Measurement techniques can be studied separately for each organ system, such as the cardiovascular, pulmonary, nervous, and endocrine systems. This approach isolates all important measurements for specialists who need to know only about a specific area, but it results in a considerable overlap of quantities sensed and principles of transduction.
- > The clinical medicine specialties, such as pediatrics, obstetrics, cardiology, or radiology. This approach is valuable for medical personnel who are interested in specialized instruments.

8

Biomedical Instrumentation Design

Risk Classification of Medical Devices in New Zealand

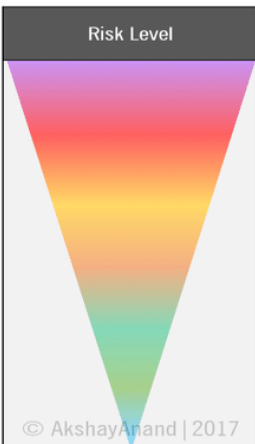
Class	Risk	Example	Risk Level
Class AIMD	High	Implantable Pacemaker	
Class III	High	Drug Eluting Cardiac Stents	
Class IIb	Medium-High	Ventilators, Orthopaedic Implants	
Class IIa	Medium-Low	Hypodermic Needles	
Class I sterile	Low	Non-Medicated Sterile Dressings	
Class I measuring	Low	Volumetric Urine Bag	
Class I basic	Low	Reusable Surgical Instruments	

© AkshayAnand | 2017

9

Biomedical Instrumentation Design

> Homework:

- > Q1: Describe the quasi-digital sensors.
- > Q2: List four medical and physiological parameters, and mention their definition, measuring range, frequency range, and standard sensor or method.
- > Q3: Describe using the following Instrumentation amplifier in ECG circuit AD620A. Note: follow the information in the datasheet

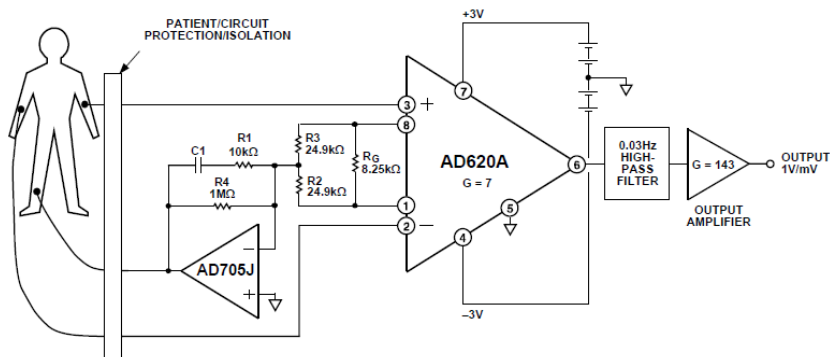

10

Biomedical Instrumentation Design

- › What is the difference between photovoltaic and photoelectric cells?
- › Recommended source!
- › [Understanding photovoltaic and photoconductive modes of photodiode operation.](#)