

Lecture -1-

Zoning the air (منطقة الهواء)

Zoning is a practice of dividing a building into smaller areas (zones), thereby providing the opportunity to control comfort levels in each zone. Zoning influence the way ducting is routed and often require multiple ducts, each feeding a respective zone.

For example, in one- story residential building, it is normal for the system to be a single zone. In some instances, two-story residences have single HVAC zones but it is difficult to maintain optimum comfort from the first floor to the second floor for obvious reasons. Because warm air rises the upstairs of the dwelling will always be warm and the downstairs will always be cooler. A two-story residences will keep each floor comfortable by HVAC zoning the systems or by having two separate systems, one for upstairs and one for downstairs.

In large commercial HVAC systems, VAV (Variable Air Volume) systems are a more complicated form of zoning. After determining the zones for the building, a preliminary layout of the ductwork is drawn. Preliminary duct layout can be drawn either in single-line (non- detailed) or double line technique.

Proper zoning provides greater comfort, reduces energy use due to over-conditioning, and reduces equipment wear. In some cases, separating central and special use zones can eliminate the need for heating equipment in these areas.

التقسيم المناطق هو عمليا تقسيم المبنى إلى مساحات أصغر (مناطق) ، وبالتالي توفير الفرصة للتحكم في مستويات الراحة في كل منطقة . يؤثر تقسيم المناطق على طريقة توجيه مجاري الهواء وغالبًا ما تتطلب قنوات متعددة ، كل منها يغذي منطقة معينة.

على سبيل المثال ، في الوحدات السكنية المكونة من طابق واحد ، من الطبيعي أن يكون النظام منطقة واحدة . اما في الوحدة السكنية المكونة من طابقين فلا يفضل استخدام نظام HVAC لمنطقة فردية لصعوبة الحفاظ على ظروف الراحة المثلى لشاغلي الحيز . نظرًا لارتفاع الهواء الدافئ، س يظل الطابق العلوي للبنية دافئًا وسيكون الطابق السفلي أكثر برودة. لكن من الممكن الحفاظ على النهاية (المكون من طابقين) على راحة كل طابق من خلال تقسيم المناطق (HVAC) أو من خلال وجود نظامين منفصلين ، أحدهما للطابق العلوي والآخر للطابق السفلي.

في أنظمة HVAC التجارية الكبيرة، تعد أنظمة حجم الهواء المتغير (VAV) شكلاً أكثر تعقيداً لتقسيم المناطق . بعد تحديد مناطق المبنى ، يتم رسم تخطيط أولي لمجاري الهواء . يمكن رسم مخطط مجرى الهواء الأولي إما في أسلوب أحادي الخط (غير مفصل) أو خط مزدوج.

يوفر تقسيم المناطق المناسب قدرًا أكبر من الراحة ، ويقلل من استخدام الطاقة بسبب الإفراط في التكييف ، ويقلل من تآكل المعدات. في بعض الحالات ، يمكن للفصل بين مناطق الاستخدام المركزي والخاصة أن يلغي الحاجة إلى معدات التدفئة في هذه المناطق.

Classification of Ducts

The ducts may be classified depending on total pressure and velocity as follows :

1. **Low pressure duct.** When the static pressure in the duct is **less than 50 mm of water gauge.**
2. **Medium pressure duct.** When the static pressure in the duct is **up to 150 mm of water gauge.**
3. **High pressure duct.** When the static pressure in the duct is **from 150 to 250 mm of water gauge.**
4. **Low velocity duct.** When the velocity of air in the duct is **up to 600 m/ min.**
5. **High velocity duct.** When the velocity of air in the duct is **more than 600 m/min.**

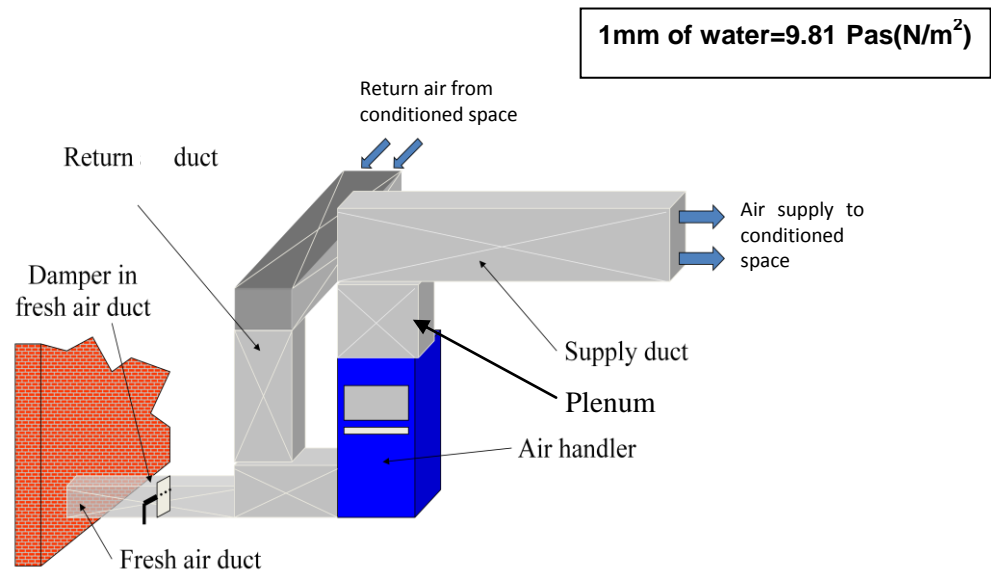

Parts of the duct system:

The duct which supplies the conditioned air from the air conditioning equipment to the space to be conditioned is called **supply air duct**. The duct which carries the recirculating air from the conditioned space back to the air conditioning equipment is called **return air duct**. The duct which carries the outside air is called **fresh air duct**. The duct which discharges air to the outdoors is called **exhaust air duct**. The **plenum** is the main part of the supply and return duct system that goes directly from the air handler

High velocities in the ducts result in:

1. Smaller size (diameter) ducts and hence, less initial cost and less space requirement
2. Higher pressure drop and hence larger fan power consumption
3. Increased noise and hence need for noise attenuation.

Recommended air velocities depend mainly on **the application and the noise criteria.**

Typical recommended velocities are:

Residences : 3 m/s to 5 m/s

بيوت او فنادق سكنية

Theatres : 4 to 6.5 m/s

مسارح

Restaurants : 7.5 m/s to 10 m/s

مطاعم

- If nothing is specified, then a velocity of 5 to 8 m/s is used for main ducts and a velocity of 4 to 6 m/s is used for the branches.
- Typically 400 cfm (11.7 m³/min) of air must be moved per minute per ton of air conditioning

Duct Shape

The ducts may be made in **circular, rectangular, oval or square** in cross section. Circular (round) ducts are preferable for high velocity system and rectangular ducts are very popular for low velocity system.

Notes:

- The size of ducts (i.e. diameter) can be decreased by increasing the air velocity. Hence it is more common to use large ducts and the resultant low velocity air flow because high velocity air flow requires more fan power to generate and is much noisier.
- 6-inch round duct delivers 100 cfm to the space.
- An 8-inch round duct delivers 200 cfm to the space.
- $\text{cfm (ft}^3/\text{min)} = \text{velocity} \times \text{cross sectional area (Q=V.A)}$

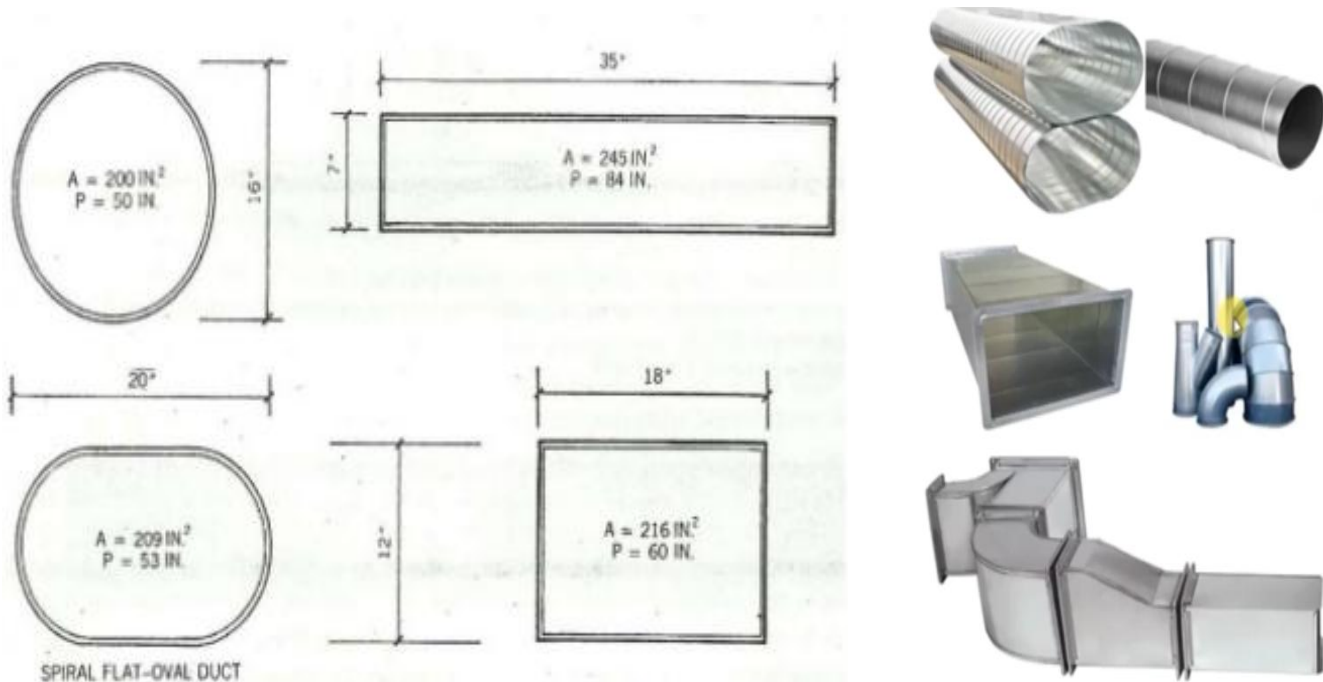

Duct material

Ducting may be classified according to the materials of construction and are **either metallic or non-metallic**. The most commonly used duct material in (HVAC) systems is **galvanized steel sheet metal** because the zinc coating of this metal prevents rusting and avoids the cost of painting. The sheet thickness of galvanized steel varies from 26 gauge (0.55 mm) to 16 gauge (1.6 mm). Next in popularity in metal ducts is **aluminum**. The aluminum is used for ductwork because of its lighter weight and resistance to moisture.

Metallic duct

1. Galvanized Steel
2. Carbon Steel (Black Iron)
3. Aluminium
4. Stainless Steel
5. Copper

Non-metallic duct

1. Fibreglass Reinforced Plastic (FRP)
2. Polyvinyl Chloride (PVC)
3. Polyvinyl Steel (PVS)
4. Flexible Nonmetallic Duct
5. Concrete
6. Rigid Fibrous Glass

Duct Construction

The sheet metal ducts **expand and contract as they heat and cool**. The fabric joints are often used to absorb this movement. In order to prevent most of the fan and furnace noise from travelling along the duct metal, the fabric joints should also be used where ducts fasten to a furnace or an air conditioner. But, in fact, most duct joints are made of sheet metal. The various types of sheet metal joints used in the construction of ducts are shown in Fig. 2.

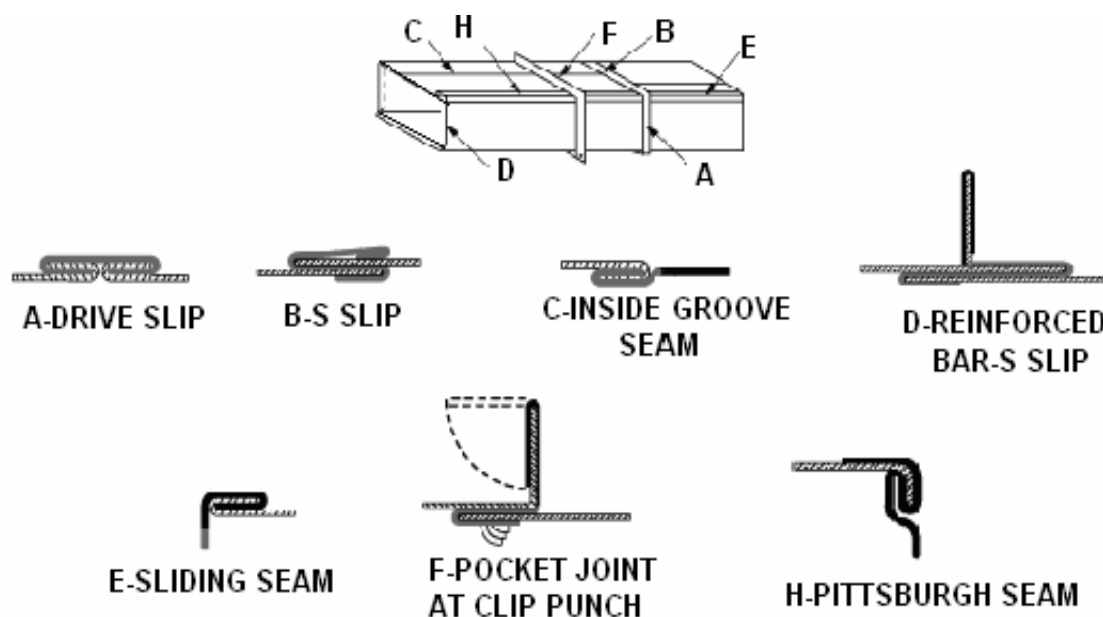

Duct Sheet Metal Thickness

The greater of the duct's dimension is the one that is used to determine the gage of the sheet metal for all sides.

أبعاد اكبر مجرى الهواء هي التي تحدد سمك الصفائح المعدنية لجميع الجوانب.

Rectangular Duct			Round Duct		
Greater Dimension	Galvanized Steel (gauge)	Aluminum (gauge)	Diameter	Galvanized Steel (gauge)	Aluminum (gauge)
Up to 30 inch	24	22	Up to 8 inch	24	22
31 – 60 inches	22	20	9 – 24 inches	22	20
61 – 90 inches	20	18	25 – 48	20	18

Ductwork fittings (انحناءات مجاري الهواء)

Figure serves to illustrate the basic forms that bends can take. **Radius bends** (see Fig. (a)) are to be preferred, and where practical a centreline radius not less than 1.5 times the diameter or duct width should be provided. **Splitters** (see Fig. (b)) should be fitted where it is important to maintain the upstream air velocity profile around the bend, e.g. at approach to equipment or measuring points. **Mitre bends** (see Fig. (c) and (d)) should not be used since pressure drop and noise generation are high.

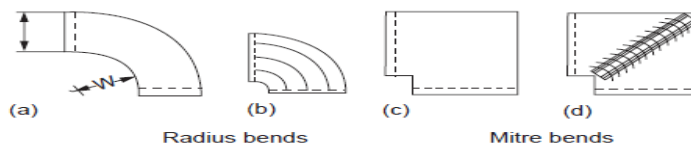

Figure 21.6 Typical ductwork bends

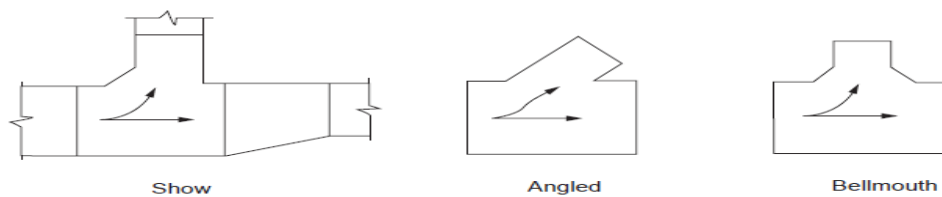

Figure 21.7 Typical ductwork branch connections

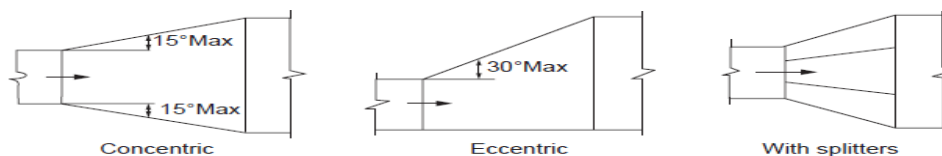
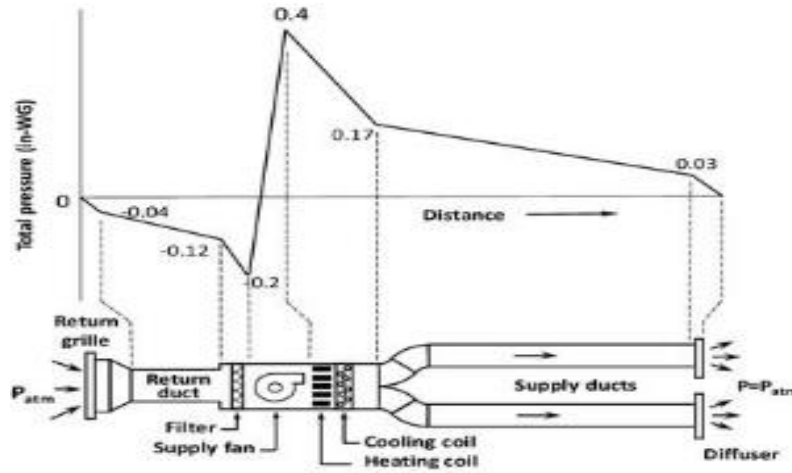

Figure 21.8 Typical ductwork expansion and contraction sections

Pressure in ducts

The schematic diagram of an air conditioning system is shown in the figure. The flow of air within the duct system is produced due to the pressure differences in different locations. The greater the pressure difference, the faster will be the air flow. The following are the three kinds of pressure evolved in a duct system.



يظهر الرسم التخطيطي لنظام تكييف الهواء في الشكل. يتم إنتاج تدفق الهواء داخل نظام مجرى الهواء بسبب اختلافات الضغط في المواقع المختلفة. كلما زاد فرق الضغط، كلما كان تدفق الهواء أسرع. فيما يلي الأنواع الثلاثة للضغط المتولدة في نظام مجرى الهواء.

1. Static pressure (Ps) - The static pressure always exist in a duct system. Since it is **not dependent** upon the air movement, it is called static (or stationary) pressure. This type of pressure pushes against the walls of the duct. It tends to burst a duct when it is greater than the atmospheric pressure and tends to collapse the confining envelope when its force is less than that of the atmosphere. The static pressure overcomes the friction and shock losses, when the air flows from the delivery of the fan to the outlet of the duct.
2. Dynamic or Velocity Pressure (Pv) - This pressure is equal to the drop in the static pressure needed to produce a given velocity of flow. Conversely, it is equal to the possible increase in static pressure, when the velocity is reduced to zero.
3. Total Pressure (PT) - The total pressure is the algebraic sum of the static pressure and dynamic or velocity pressure. Mathematically total pressure of air is

$$P_T = P_s + P_v$$

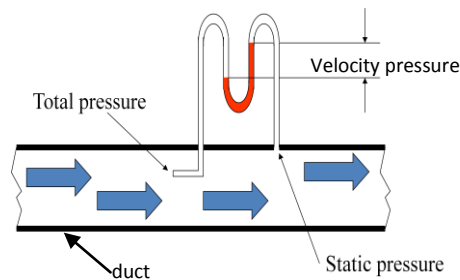

Duct Design Methods

The main goal of designing HVAC duct system is to size the duct so as to minimize the pressure drop through the duct, while keeping the size (and cost) of the ductwork to a minimum. First hand operating cost considerations dictate that duct systems should be designed to operate at the lowest possible static pressure. The most widely used method to size duct is equal friction loss method. The other methods are velocity reduction method and static regain method.

الهدف من تصميم مجرى الهواء هو تحديد حجم مجرى الهواء لتقليل انخفاض الضغط عبر المجرى وبالتالي تقليل كلفة مجاري الهواء إلى الحد الأدنى.