

Ministry of Higher Education and Scientific Research
Al-Mustaqbal University
College of Engineering & Technology
Medical Instrumentation Techniques Engineering Department
Electrical Technology
Third Class

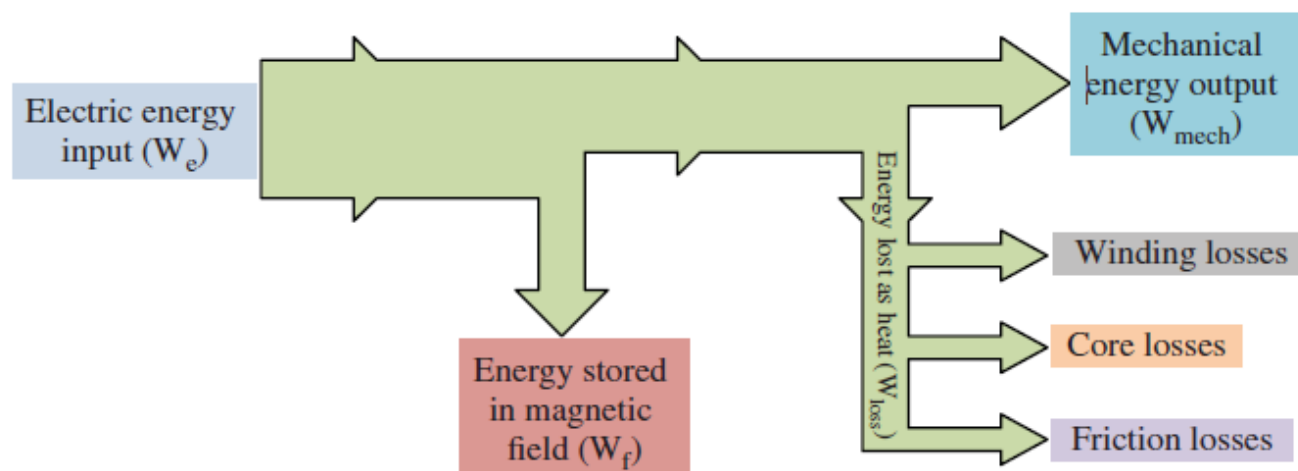

Weeks 9,10 &11

Electromechanical energy conversion



By Osamah Jaber Ghayyib

1. INTRODUCTION

We daily use many devices that convert one form of energy into another form. For example, a heater converts electrical energy into heat energy while an electric bulb converts electrical energy into light energy. However, electromechanical conversion devices (i.e., devices that convert electrical energy into mechanical energy or vice — versa) find wide practical applications. For example, an electric motor converts electrical energy into mechanical energy. On the other hand, an electric generator converts mechanical energy into electrical energy. A major reason for the widespread use of electro-mechanical energy conversion devices is that they are relatively efficient and permit an easy control.

2. ELECTROMECHANICAL ENERGY CONVERSION

The conversion of electrical energy into mechanical energy or vice versa is known as electromechanical energy conversion. Electromechanical energy conversion involves the interchange of energy between an electrical system and a mechanical system through the medium of a coupling electric field or magnetic field. Therefore, an electromechanical conversion system has three essential parts , an electrical system, a mechanical system and a coupling field (electric or magnetic). Fig. 1 shows the block diagram of an electromechanical energy conversion system. Note that from left to right, the system represents con-version from electrical to mechanical . However, from right to left, it will represent conversion from mechanical to electrical.

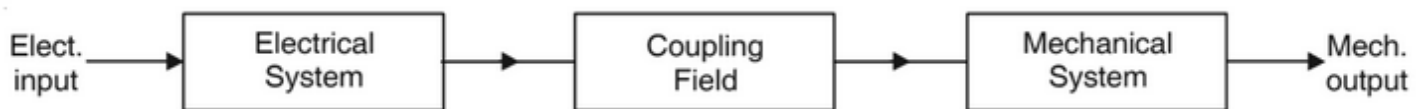

Fig.1 Electromechanical Energy Conversion System.

(i) **Electric field as coupling medium.** Electromechanical energy conversion can take place when electric field is used as the medium. Consider two oppositely charged plates of a capacitor which are separated by a dielectric medium. A force of attraction exists between the two plates that tends to move them together. If we allow one plate to move in the direction of the force, we are converting electrical energy into mechanical energy. On the other hand, if we apply an external force on one plate and try to increase the separation between them, we are then converting mechanical energy into electrical energy. Electrostatic microphones and electrostatic voltmeters use electrostatic fields for energy conversion.

(ii) **Magnetic field as coupling medium.** Electromechanical energy conversion can also take place more effectively when magnetic field is used as the medium. Consider the case of a current-carrying conductor placed in a magnetic field. The conductor experiences a force that tends to move it. If the conductor is free to move in the direction of the magnetic force, the magnetic field helps the conversion of electrical energy into mechanical energy. This is essentially the principle of operation of all electric motors. On the other hand, if an externally applied force moves the conductor in a direction opposite to the magnetic force, mechanical energy is converted into electrical energy. The generator action is based on this principle. Note that in both cases, the magnetic field acts as a medium for energy conversion.

It is important to note that the quantity of energy that can be converted by a device using electric field as a medium is relatively small. It is because the amount of force developed by an electric system is usually very small even when the applied voltage is high and the physical dimensions of the system are quite large. However, when magnetic field is used as a medium, a system with the same physical dimensions develops a much larger force than a system using an electric field as a medium. For this reason, the use of electric field as a medium for energy conversion has limited applications.

3. ELECTROMECHANICAL ENERGY CONVERSION DEVICES

Electromechanical energy conversion takes place through electric field or magnetic field as the medium. Although the various conversion devices operate on common set of physical principles, the structures of the devices depend on their function. Electromechanical energy conversion devices can be divided into the following three categories :

(i) Transducers. These conversion devices are used for measurement and control. They generally operate under linear input-output conditions and with relatively small signals. Examples include microphones, pickups and loudspeakers.

(ii) Force-producing devices. These conversion devices are meant for producing force or torque with limited mechanical motion. Examples include relays, solenoid actuators and electromagnets.

(iii) Continuous energy conversion devices. These devices continuously convert electrical energy into mechanical energy or vice versa. They are used for bulk energy conversion and utilization. Motors and generators are the examples of such conversion devices.

It may be noted that magnetic field is most suited as a medium for electromechanical energy conversion. Therefore, in this lecture, we shall deal with magnetic field as the medium of energy conversion.

4. FEATURES OF ELECTROMECHANICAL ENERGY CONVERSION

Electromechanical energy conversion takes place through the medium of magnetic field. The following features are worth noting in this energy conversion :

- (i) As with any energy conversion system, the principle of conservation of energy holds good in case of electromechanical energy conversion. That is energy can neither be created nor destroyed; it can only be changed from one form to another.

- (ii) During electromechanical energy conversion, various losses occur in the system. This is illustrated in Fig. 2 which shows the conversion of electrical energy into mechanical energy.

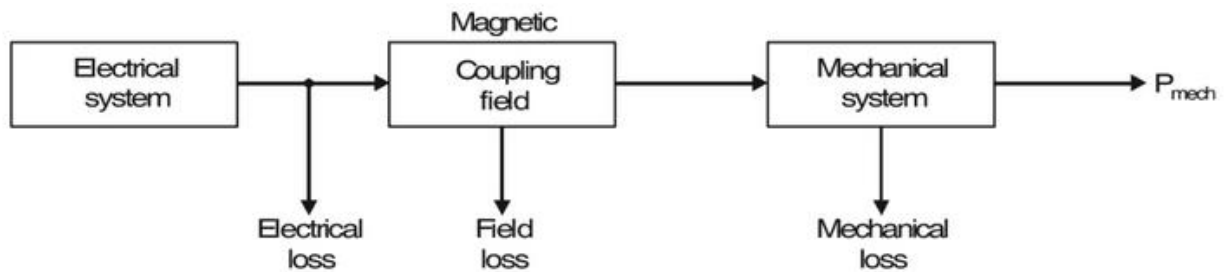

Fig.2 Electromechanical Energy Conversion System.

The electrical energy loss ($i^2 R$) is due to current (i) flowing in the winding (having resistance R) of the energy converter. The field loss is the core loss due to changing magnetic field in the magnetic core. The mechanical loss is the friction and windage loss due to the motion of the moving components. All these losses are converted into heat and raise the temperature of the energy conversion system.

- (iii) Electromechanical energy conversion is a reversible process except for the losses in the system. The term reversible means that the energy can be transferred back and forth between the electrical and the mechanical systems. However, each time we go through an energy conversion process, some of the energy is used up to meet the losses in the conversion process. These losses are converted into heat and are lost from the system forever.
- (iv) Electromechanical conversion devices are built with air gaps in the magnetic circuit to separate the fixed and moving parts. Most of the m.m.f. of the windings is required to overcome the air-gap reluctance so that most of the energy is stored in the air gap and is returned to the electric source when the field is reduced.

- (v) The electromechanical energy conversion system can be analyzed by using principle of conservation of energy, laws of electric and magnetic field, electric circuits and Newtonian mechanics.
- (vi) The rotating electrical machines (motors and generators) continuously convert electrical energy into mechanical energy or vice versa. Fig. 3 shows the block diagram of electromechanical energy conversion in an electrical machine. The primary quantities involved in the mechanical system are torque (T) and speed (ω_m) while the analogous quantities in the electrical system are voltage (e) and current (i) respectively.

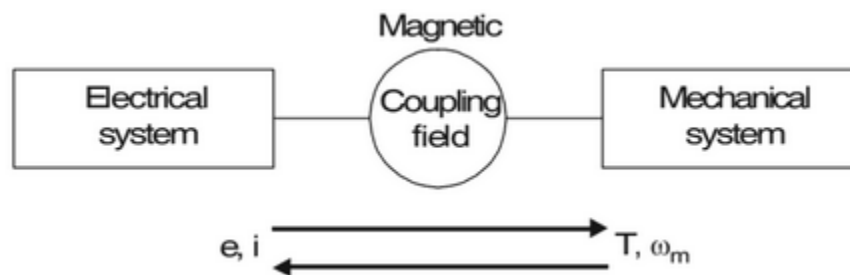

Fig.3 Electromechanical Energy Conversion System.

5. ENERGY BALANCE EQUATION

An electromechanical energy conversion system has three essential parts, an electrical system, a mechanical system and a coupling magnetic field as shown in Fig. 2. Since conversion of energy from one form into another form satisfies the principle of conservation of energy, the energy transfer equation is as under:

$$\left(\begin{array}{c} \text{Electrical energy} \\ \text{input from source} \end{array} \right) = \left(\begin{array}{c} \text{Mechanical energy} \\ \text{out} \end{array} \right) + \left(\begin{array}{c} \text{Increase in energy} \\ \text{Stored in coupling field} \end{array} \right) + \left(\begin{array}{c} \text{Energy} \\ \text{Loss} \end{array} \right) \quad (1)$$

Eq (1) is applicable to all conversion devices. For motor action, the electrical and mechanical energy terms have positive values. For generator action, the electrical and mechanical energy terms have negative values.

During this energy conversion, energy loss occurs due to three causes ,

- (i) i^2R loss in the winding of the energy converter.
 - (ii) core or field loss due to changing magnetic field.
 - (iii) mechanical loss is the friction and windage loss due to the motion of moving parts.
- All these losses are converted to heat. If the energy losses in the electrical system, the coupling magnetic field and the mechanical system are grouped with the corresponding terms in eq. (1), the energy balance equation can be written as under:

$$\left(\begin{array}{c} \text{Electrical energy} \\ \text{input from source} \end{array} \right) = \left(\begin{array}{c} \text{Mechanical energy} \\ \text{out} \end{array} \right) + \left(\begin{array}{c} \text{Increase in energy} \\ \text{Stored in coupling field} \end{array} \right) \quad (2)$$

Now consider a differential time dt during which an increment of electrical energy dW_e flows to the system. During this time dt , let dW_f , be the energy supplied to the field and dW_m the energy converted to mechanical form. In differential form, eq. (2) can be expressed as

$$dW_e = dW_f + dW_m \quad (3)$$

6. ENERGY IN MAGNETIC SYSTEM

6.1 Singly excited electromechanical system (stationary)

Consider singly—excited magnetic system shown in Fig. 4. It is the magnetic system of an attracted armature relay. Here a coil of N turns wound on the magnetic core is connected to an electric source.

Let us assume that the armature is held stationary at some air gap and the current is increased from zero to some value i . As a result, flux Φ will be established in the magnetic system.

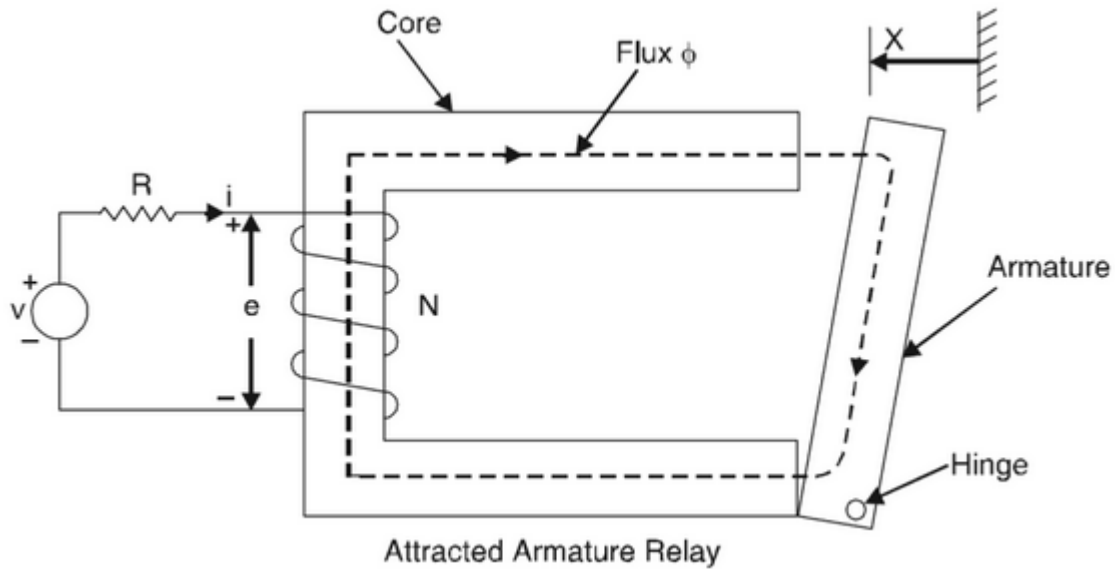

Fig.4 Example of singly excited system.

$$\text{Total flux linkages, } \lambda = N\Phi$$

$$e = N \frac{d\Phi}{dt} = \frac{d}{dt} N\Phi = \frac{d\lambda}{dt}$$

For the coupling device to absorb energy from the electric circuit, the coupling field must produce a reaction in the circuit. This reaction is the e.m.f. e produced by the magnetic field.

The incremental electrical energy due to the flow of current in time dt is

$$dW_e = ei dt$$

The energy balance equation in differential form is

$$dW_e = dW_f + dW_m$$

We assume there the armature is held stationary then.

$$dW_e = dW_f$$

$$ei dt = dW_f$$

$$\frac{d\lambda}{dt} idt = dW_e = dW_f$$

$$dW_f = d\lambda i = Ni d\Phi \quad (4)$$

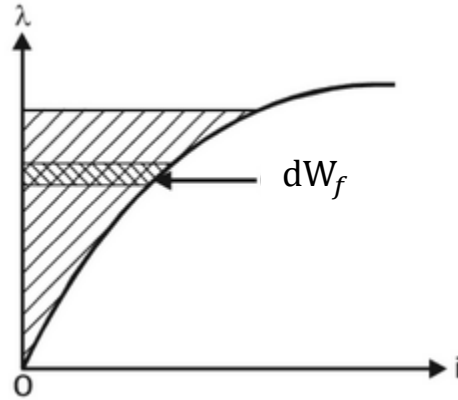

Fig.5 Example of singly excited system.

The relationship between coil flux linkages λ and current i for a particular air-gap length is shown in Fig. 5 The incremental field energy dW_f , is shown as crosshatched area in this figure. When the flux linkage is increased from zero to λ (or flux from zero to Φ),the energy stored in the field is:

$$W_f = \int_0^{\lambda} i d\lambda = N \int_0^{\Phi} i d\Phi \quad (5)$$

Since

$$Ni = H_g l_g + H_c l_c, \quad B = \frac{\Phi}{A}, \quad B = \mu H$$

Then

$$W_f = N \int_0^{\Phi} i d\Phi = \int_0^B H_g l_g A_g dB + \int_0^B H_c l_c A_c dB \quad (6)$$

$$W_f = V_g \int_0^B H_g dB + V_c \int_0^B H_c dB \quad (7)$$

The energy stored in core equals:

$$W_{fc} = V_c \int_0^B H_c dB$$

And for air gap :

$$W_{fg} = V_g \int_0^B H_g dB = V_g \int_0^B \frac{B}{\mu_0} dB = V_g \frac{B^2}{2\mu_0}$$

Example 1. The magnetic core of system below is made of cast steel whose B-H characteristic is shown below. The coil has 250 turns and the coil resistance is 5Ω . For a fixed air gap length $g = 5$ mm, a D.C. source is connected to the coil to produce a flux density of $B=1$ tesla in the air gap.

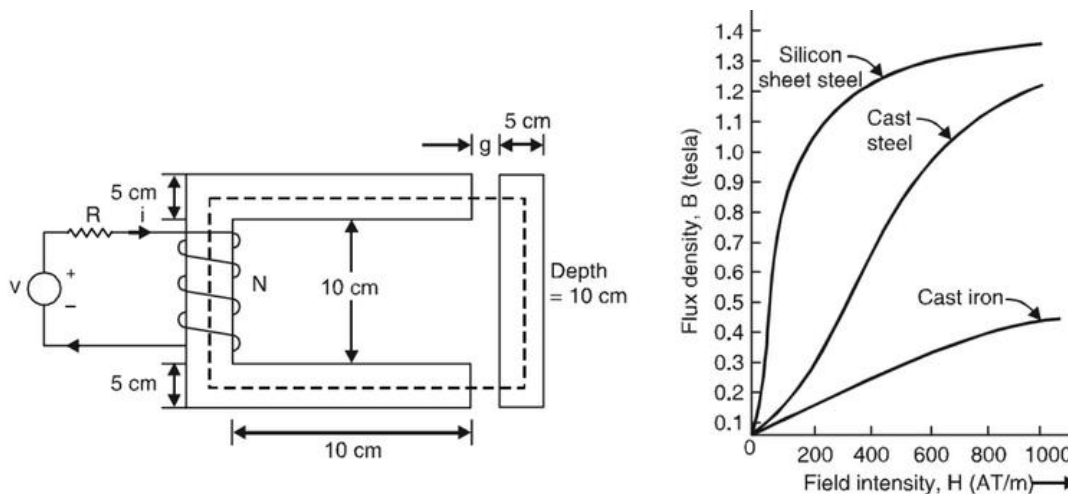

(i) Find the voltage of D.C. source. (ii) Find the stored field energy.

Solution

$$B = 1 \text{ T}, N = 250, R = 5\Omega, l_g = 5 \text{ mm}$$

(i) From B-H figure we find $H = 670 \text{ AT/m}$

Length of $l_c = 2(10 + 5) + 2(10 + 5) = 60 \text{ cm} = 0.6 \text{ m}$

Magnetic intensity of air gap H_g can be found as

$$H_g = \frac{B_g}{\mu_0} = \frac{1}{4\pi \times 10^{-7}} = 795.8 \times 10^3 \text{ AT/m}$$

$$mmf = Ni = 2H_g l_g + H_c l_c$$

$$Ni = (670 \times 0.6) + (795.8 \times 10^3 \times 2 \times 5 \times 10^{-3}) = 8360 \text{ AT}$$

$$i = \frac{8360}{250} = 33.4 \text{ A}$$

Then the voltage of dc source is $V = iR = 33.4 \times 5 = \mathbf{167.2 \text{ V}}$

(ii) Field energy stored in core :

$$W_{fc} = V_c \int_0^1 H_c dB$$

Since $A=0.1 \times 0.05 = 0.005 \text{ m}^2$ then

$$V_c = 0.005 \times [(2 \times 0.2) + (2 \times 0.1)] = 0.003 \text{ m}^3$$

$$W_{fc} = 0.003 \int_0^1 H_c dB \cong 0.003 \times \frac{1}{2} \times 1 \times 670 = \mathbf{1 \text{ J}}$$

Field energy stored in air gaps is given by :

$$W_{fg} = V_g \frac{B^2}{2\mu_0} = 0.05 \times 10^{-3} \times \frac{1^2}{2 \times 4\pi \times 10^{-7}} = \mathbf{19.9 \text{ J}}$$

Then the total stored field energy is :

$$W_f = W_{fc} + W_{fg} = 20.9 \text{ J}$$

6.2 Singly excited electromechanical system (non-stationary)

The $\lambda - i$ characteristic of an electromagnetic system depends on the air gap length and B-H characteristic of the magnetic material. These $\lambda - i$ characteristics are shown in Fig. 6 for three values of airgap length. If the air gap length is large, the characteristic is essentially linear. The characteristic becomes nonlinear as the air gap length decreases.

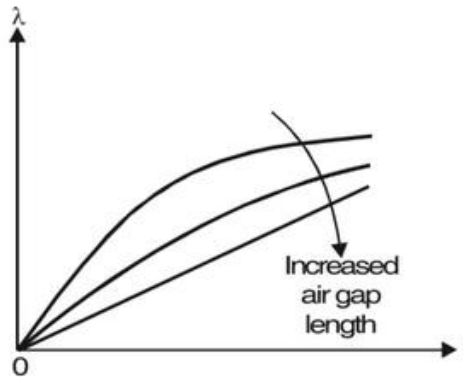

Fig.6 Effect of change in air gap over $\lambda - i$ characteristics.

Another quantity can be defined from the $\lambda - i$ characteristics is called (in Fig 7) the **Co-energy** and defined as :

$$W_f' = \int_0^i \lambda di$$

This quantity has no physical significance. From $\lambda - i$ characteristics ,the sum of both W_f and W_f' as follows:

$$W_f + W_f' = \lambda i$$

If the relation $\lambda - i$ is linear, then $W_f = W_f'$.

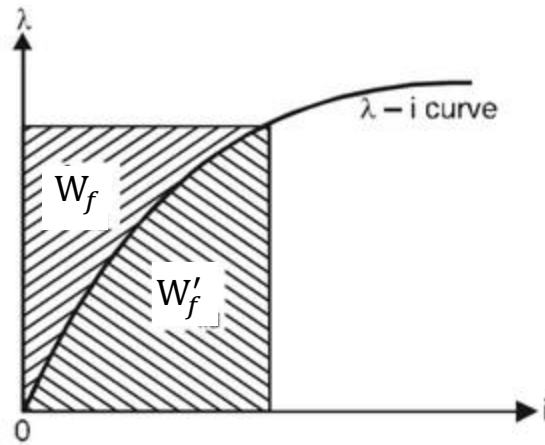

Fig. 7 energy and Co-energy field.

Now let's consider the electromagnetic system shown in Fig. 7. Let the current through the coil be when a voltage source v is applied across its terminals. The current i sets up magnetic flux ϕ in the magnetic circuit. The flux linkages induce an e.m.f. e in the coil.

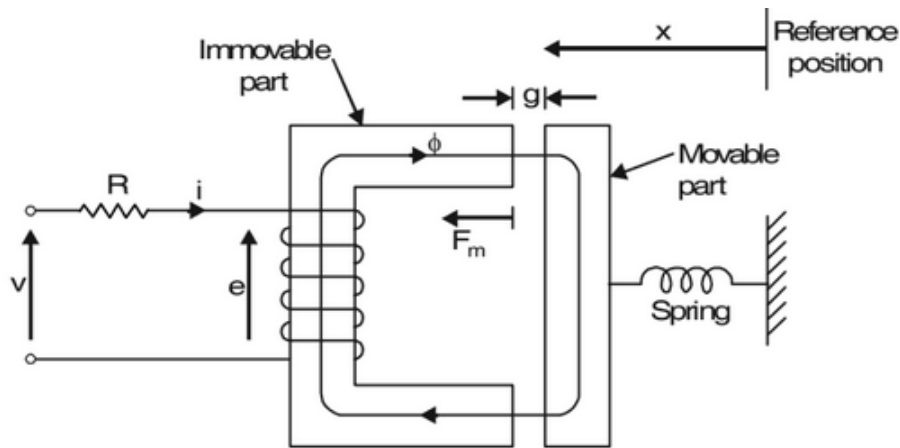

Fig. 8 energy and Co-energy field.

Suppose the movable part moves from one position (say $x = x_1$) to another position ($x = x_2$) so that at the end of the movement, the air gap decreases. The $\lambda - i$ characteristics of the system for these two positions are shown in Fig. 9(i). Note that operating points of the system are **a** when $x = x_1$, and **b** when $x = x_2$. The current $i (= v/R)$ will remain the same at both the positions in the steady state.

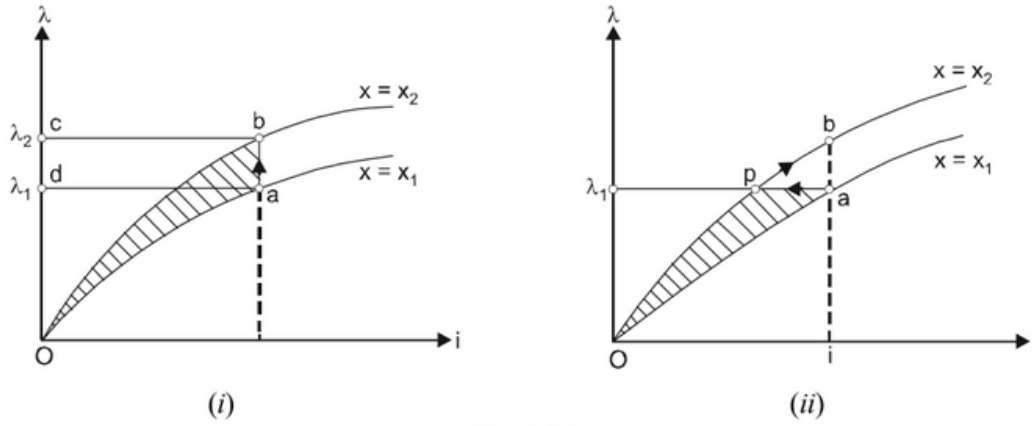

Fig. 9 energy and Co-energy field.

If we assume the system have a linear $\lambda - i$ relation then :

$$\lambda = L(x) i \quad (8)$$

Where $L(x)$ is the inductance of the coil which depends on length of the air gap x . The energy field is given by:

$$W_f = \int_0^\lambda i d\lambda = \int_0^\lambda \frac{\lambda}{L(x)} d\lambda = \frac{\lambda^2}{2 L(x)} = \frac{1}{2} L(x) i \quad (9)$$

From Eq 3 we know that :

$$dW_f = dW_e - dW_m = i d\lambda - F dx$$

Since W_f is a function of both λ and x then

$$dW_f(\lambda, x) = \frac{\partial W_f(\lambda, x)}{\partial \lambda} d\lambda + \frac{\partial W_f(\lambda, x)}{\partial x} dx$$

By comparing the above two equations we conclude:

$$i = \frac{\partial W_f(\lambda, x)}{\partial \lambda} \text{ and } F = -\frac{\partial W_f(\lambda, x)}{\partial x}$$

From Eq 9 we can find F :

$$F = -\frac{\partial W_f(\lambda, x)}{\partial x} = -\frac{\partial}{\partial x} \left(\frac{\lambda^2}{2 L(x)} \right) \Big|_{\lambda = \text{constant}} = \frac{i^2}{2 (L(x))^2} \frac{dL(x)}{dx}$$