

Ministry of Higher Education and Scientific Research

Al-Mustaqbal University

College of Engineering & Technology

Medical Instrumentation Techniques Engineering Department

Electrical Technology

Third Class



Weeks 7 & 8

Three Phase Transformers



By **Osamah Jaber Ghayyib**

1. What is a three phase transformers

Three-phase transformers are passive machines that pass electrical energy between circuits. In the secondary circuit, a magnetic flux induces an electromotive force (emf), thus stepping up (increase) or stepping down (decrease) voltages without altering the frequency. There are different kinds of electrical systems, and therefore transformers have to operate alongside compatible systems. A three-phase transformer works with a three-phase AC (alternating current) electrical system to provide consumers with stable and device-safe electricity. Depending on the industry or application, the size, design, volt-ampere rating, and load-bearing capabilities of the three-phase transformer will differ.

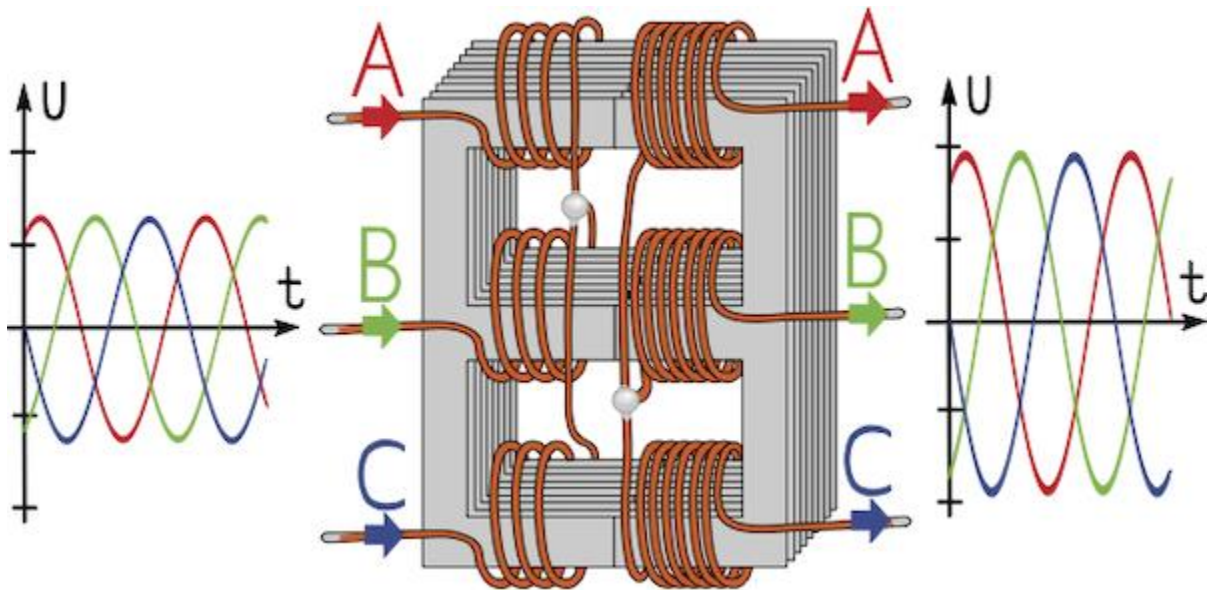
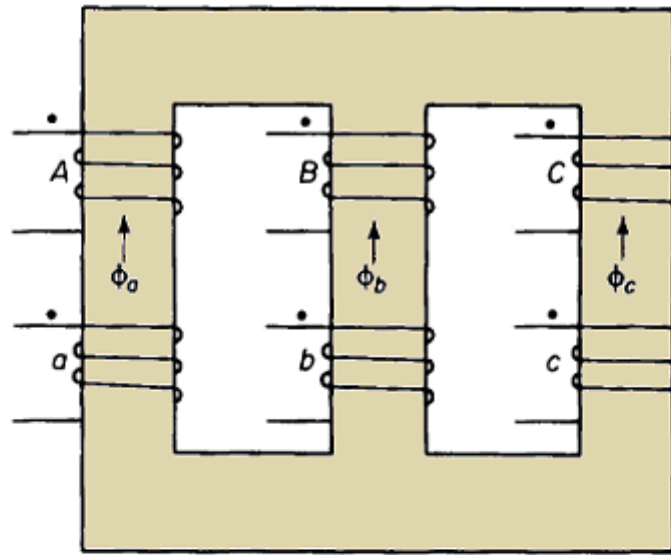

Fig.1 A three-phase transformer having three sets of windings on both primary and secondary sides

2. Construction of a Three Phase Transformer

Three-phase transformers can be categorized depending on their construction. There are two types of 3-phase transformers: the core-type with primary and secondary windings wound on one core and the shell-type transformer that combines three 1-phase transformers.



(a)

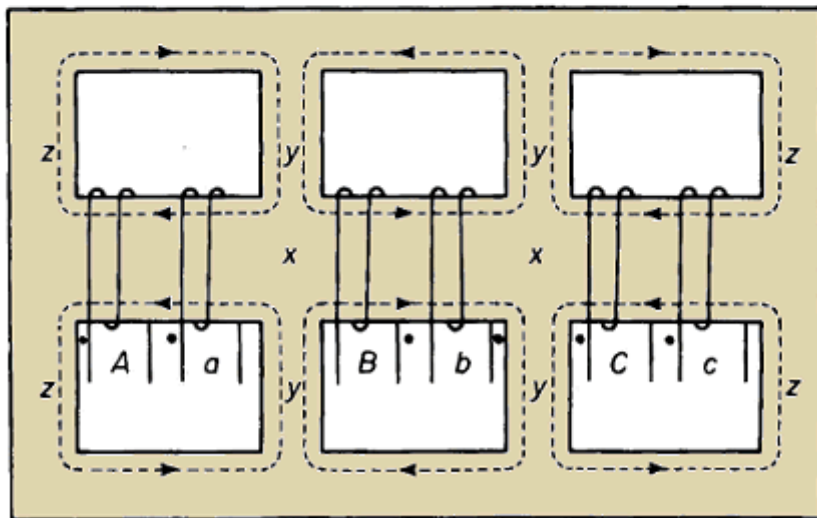

(b)

Fig.2 Types of three phase transformer (a) Core type (b) Shell type.

2.1 Core-type

In core-type three-phase transformers, [the core](#) has three limbs within the same plane. Each limb contains primary and secondary windings, and these windings are evenly split among the three limbs. It's not uncommon to hear of high voltage (HV) and low voltage (LV) windings.

As a low voltage winding is easier to insulate, these windings are closer to the core than the higher voltage coils. The latter windings wrap around the former, with insulative material between them. This construction has the windings magnetically linked with one another, with one winding using the other pair of limbs as return paths for its magnetic flux (see Figure 2(a)).

2.2 Shell-type

The shell-type 3-phase transformer is three separate 1-phase transformers. The three phases of this transformer have their magnetic fields virtually independent, and this transformer's core has five limbs as seen in Figure 2 (b).

The HV and LV windings exist around the three main limbs. Like the core-type 3-phase device, the low voltage coil is nearest the core. The two outermost limbs serve as the flux's return paths.

Magnetic flux divides in two as the field approaches the yoke. It's common for the outer limbs and the yoke to be half the size of the main limbs. You can decrease the transformer's height by reducing the yoke's size.

3. Three Phase Transformer Connections

A *three phase transformer* or 3ϕ transformer can be constructed either by connecting together three single-phase transformers, thereby forming a so-called three phase transformer bank, or by using one pre-assembled and balanced three phase transformer which consists of three pairs of single phase windings mounted onto one single laminated core.













Primary Configuration		Secondary Configuration	
Delta (Mesh)		Delta (Mesh)	
Delta (Mesh)		Star (Wye)	
Star (Wye)		Delta (Mesh)	
Star (Wye)		Star (Wye)	
Interconnected Star		Delta (Mesh)	
Interconnected Star		Star (Wye)	

Fig.3 Symbols of winding connections.

The advantages of building a single three phase transformer is that for the same kVA rating it will be smaller, cheaper and lighter than three individual single phase transformers connected together because the copper and iron core are used more effectively. The methods of connecting the primary and secondary windings are the same, whether using just one **Three Phase Transformer** or three separate *Single Phase Transformers*.

The possible connections that will be reviewed in this section are:

- Input star (Y), output delta (Δ)
- Input delta (Δ), output star (Y)
- Input delta (Δ), output delta (Δ)
- Input star (Y), output star (Y).

3.1 Input (Y), Output (Δ)

The connection diagram with primary as star and secondary as delta is shown in Figure 4. This type of connection is mostly used in step-down applications. The high-voltage side (star connected) can be grounded, which is desirable. Given the primary line voltage, V and line current

I and turn ratio $k = N_2/N_1$. The phase voltage of the primary side is given as $V/\sqrt{3}$ and the phase current is same as the line current.

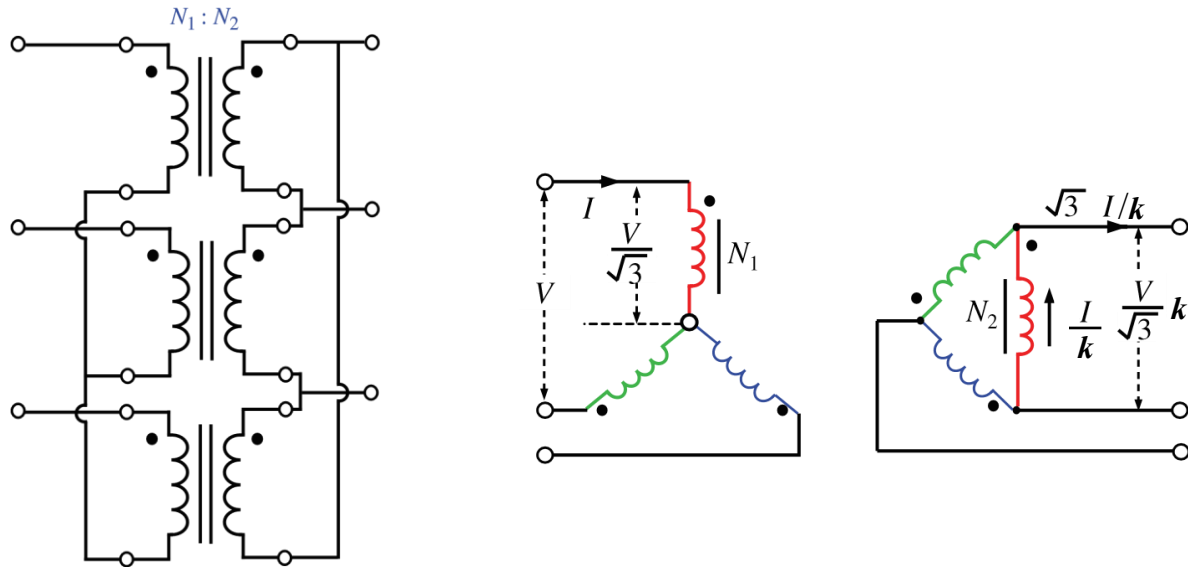

Fig.4 Star-delta three-phase transformer connection.

The phase voltage is transformed to the secondary phase voltage as:-

$$\frac{V_{P2}}{V_{P1}} = k \Rightarrow \frac{V_{P2}}{V/\sqrt{3}} = k \Rightarrow V_{P2} = k \frac{V}{\sqrt{3}}$$

The primary side phase current is transformed to the secondary side phase current as:

$$\frac{I_{P1}}{I_{P2}} = k \Rightarrow \frac{I}{I_{P2}} = k \Rightarrow I_{P2} = \frac{I}{k}$$

The secondary phase quantities are now transformed to the line quantities as:

Line Voltage = Phase Voltage (because of delta connection)

$$V_{L2} = V_{P2} = k \frac{V}{\sqrt{3}} \quad , \quad I_{L2} = \sqrt{3} I_{P2} = \sqrt{3} \frac{I}{k}$$

3.2 Input Delta (Δ), Output Star (Y)

The connection diagram with input delta and output star is shown in Figure 5. This type of transformer connection is used for step-down applications. Given the primary line voltage, V and line current I and turn ratio $k = N_2/N_1$. The phase voltage of the primary side is the same as line voltage (delta connection) and the phase current is $I/\sqrt{3}$. The phase voltage is transformed to the secondary phase voltage as:-

$$\frac{V_{P2}}{V_{P1}} = k \Rightarrow \frac{V_{P2}}{V} = k \Rightarrow V_{P2} = kV$$

The primary side phase current is transformed to the secondary side phase current as

$$\frac{I_{P1}}{I_{P2}} = k \Rightarrow \frac{I/\sqrt{3}}{I_{P2}} = k \Rightarrow I_{P2} = \frac{I}{k\sqrt{3}}$$

The secondary phase quantities are now transformed to the line quantities as

Line Current = Phase Current (because of delta connection)

$$V_{L2} = \sqrt{3}V_{P2} = \sqrt{3} kV \quad , \quad I_{L2} = I_{P2} = \frac{I}{k\sqrt{3}}$$

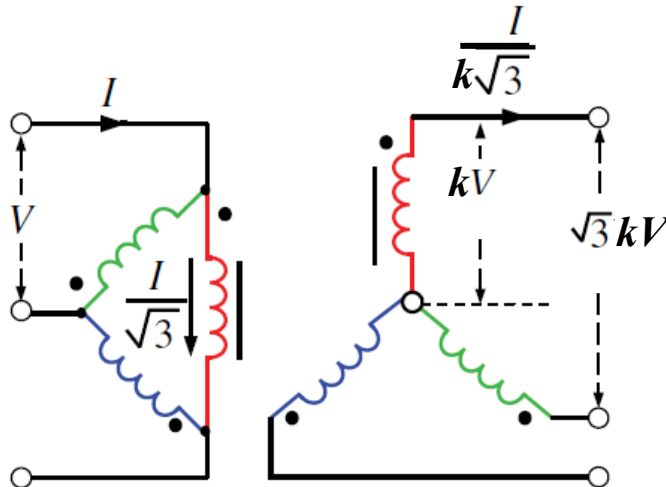

Fig.5 Delta-star connection of three-phase transformer

3.3 Input Delta (Δ), Output Delta (Δ)

The connection diagram with input delta and output delta is shown in Figure 6. This type of transformer connection is used for a reliable power supply system. If one of the transformers is faulty, it can be removed and the whole system run in open-delta mode or V connection. The output power can still be supplied in this mode. The 58% of the rated can be supplied in open-delta mode. The voltage current relationship can be obtained in the same way.

Given the primary line voltage, V and line current I and turn ratio $k = N_2/N_1$. The phase voltage of the primary side is the same as line voltage (delta connection) and the phase current is $I/\sqrt{3}$.

The phase voltage is transformed to the secondary phase voltage as

$$\frac{V_{P2}}{V_{P1}} = k \Rightarrow \frac{V_{P2}}{V} = k \Rightarrow V_{P2} = kV$$

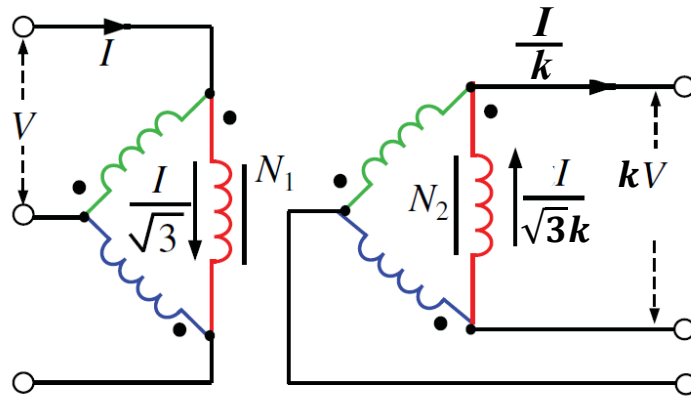

Fig.6 Delta-delta connection of three-phase transformer.

The primary side phase current is transformed to the secondary side phase current as

$$\frac{I_{P1}}{I_{P2}} = k \Rightarrow \frac{I/\sqrt{3}}{I_{P2}} = k \Rightarrow I_{P2} = \frac{I}{k\sqrt{3}}$$

The secondary phase quantities are now transformed to the line quantities as

Line Voltage = Phase Voltage (because of delta connection)

$$V_{L2} = V_{P2} = kV \quad , \quad I_{L2} = \sqrt{3}I_{P2} = \frac{\sqrt{3}I}{\sqrt{3}k} = \frac{I}{k}$$

3.4 Input Star (Y), Output Star (Y)

The connection diagram of star primary and star secondary is shown in Figure 7. This type of connection is not very commonly in use because of the problem with the exciting current (distorted current with harmonic content). Given the primary line voltage, V and line current I and turn ratio $k = N_2/N_1$. The phase voltage of the primary side is given as $V/\sqrt{3}$ and the phase current is same as the line current.

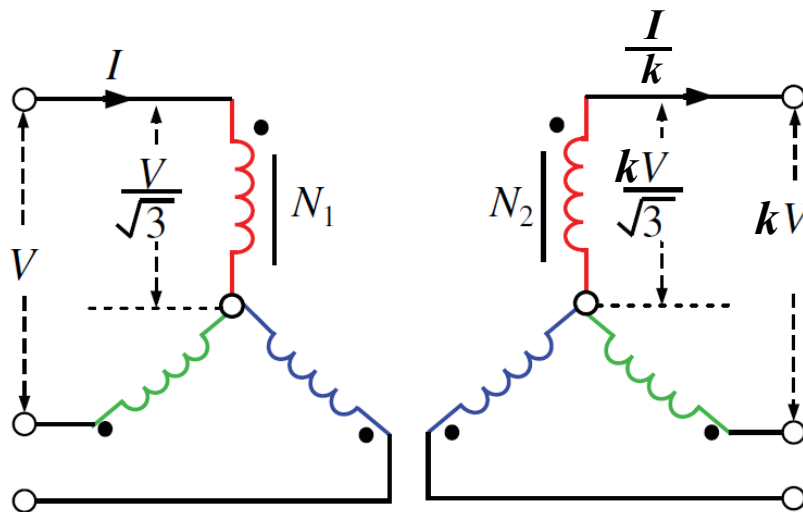

Fig.7 Star-star connection of three-phase transformer.

The phase voltage is transformed to the secondary phase voltage as

$$\frac{V_{P2}}{V_{P1}} = k \quad \Rightarrow \quad \frac{V_{P2}}{V/\sqrt{3}} = k \quad \Rightarrow \quad V_{P2} = k \frac{V}{\sqrt{3}}$$

The primary side phase current is transformed to the secondary side phase current as

$$\frac{I_{P1}}{I_{P2}} = k \Rightarrow \frac{I}{I_{P2}} = k \Rightarrow I_{P2} = \frac{I}{k}$$

The secondary phase quantities are now transformed to the line quantities as;

$$V_{L2} = \sqrt{3} V_{P2} = kV \quad , \quad I_{L2} = I_{P2} = \frac{I}{k}$$

Example 1: A three phase transformer has delta connected primary and a star connected secondary working on 50 Hz three phase supply. The line voltages of primary and secondary are 3300 V and 400 V respectively. The line current on the primary side is 12 A and secondary has a balanced load at 0.8 lagging p.f. Determine the secondary phase voltage line current and the output.

Solution

$$V_{L1} = 3300 \text{ V} , \quad I_{L1} = 12 \text{ A} , \quad \text{Secondary power factor} = 0.8$$

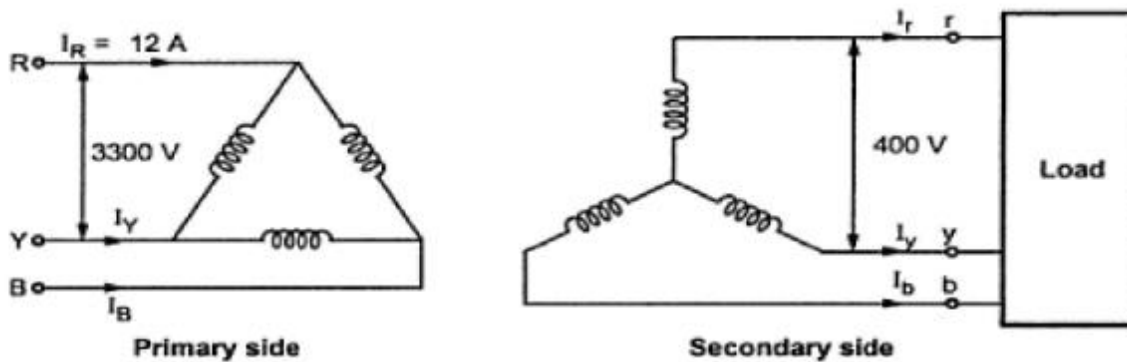

Primary side : $V_{P1} = V_{L1} = 3300 \text{ V}$

Secondary side : $V_{P2} = \frac{V_{L2}}{\sqrt{3}} = \frac{400}{\sqrt{3}} = 230.94 \text{ V}$

$$k = \frac{V_{P2}}{V_{P1}} = \frac{230.94}{3300} = 0.0699$$

Primary side : $I_{P1} = \frac{I_{L1}}{\sqrt{3}} = \frac{12}{\sqrt{3}} = 6.928 \text{ A}$

Secondary side :

$$k = \frac{I_{P1}}{I_{P2}} \Rightarrow I_{P2} = \frac{I_{P1}}{k} = \frac{6.928}{0.0699} = 99.11 \text{ A}$$

Since secondary is connected in star

$$I_{P2} = I_{L2} = 99.11 \text{ A}$$

$$\text{Power output} = \sqrt{3} V_{L2} I_{L2} \cos \phi_L = \sqrt{3} \times 400 \times 99.11 \times 0.8 = 54.94 \text{ kW}$$

Example 2: A 3-phase, 50-Hz transformer has a delta-connected primary and star-connected secondary, the line voltages being 22,000 V and 400 V respectively. The secondary has a star connected balanced load at 0.8 power factor lagging. The line current on the primary side is 5 A. Determine the current in each coil of the primary and in each secondary line. What is the output of the transformer in kW?

Solution

It should be noted that in three-phase transformers, the *phase* transformation ratio is equal to the turn ratio but the terminal or line voltages depend upon the method of connection employed.

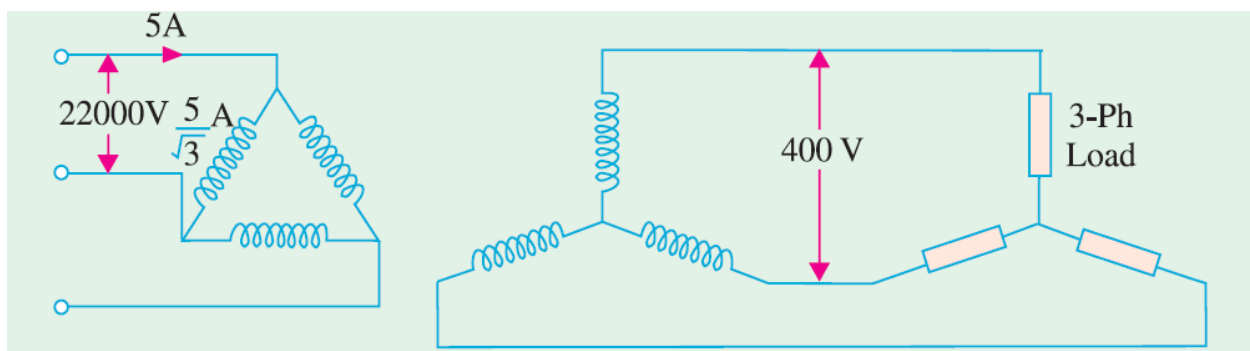

$$V_{P1} = 22,000 \text{ V} , V_{P2} = 400 / \sqrt{3} \text{ V}$$

$$k = V_{P2} / V_{P1} = 400 / (22000 \times \sqrt{3}) = 1 / 55\sqrt{3}$$

$$I_{P1} = 5/\sqrt{3} \text{ A} , \quad k = I_{P1}/I_{P2} \Rightarrow I_{P2} = I_{P1}/k = \frac{5/\sqrt{3}}{\frac{1}{55\sqrt{3}}} = 275 \text{ A}$$

$$P_{\text{out}} = \sqrt{3} V_{L2} I_{L2} \cos \phi_L = \sqrt{3} \times 400 \times 275 \times 0.8 = 15.24 \text{ kW}$$

3.5 Single phase transformer vs three phase transformer

Following are the main differences between a 1-phase and a 3-phase transformer.

No	Single Phase Transformer	Three Phase Transformer
1	Single-phase transformer has only one primary winding and one secondary winding.	Three-phase transformer has three-primary windings and three secondary windings.
2	Single-phase transformer has two input terminals and two output terminals	In case of three-phase transformer, there are three input terminals for line wires and one terminal is for neutral (depending upon the type of primary winding connection), and similarly, at the output, three line terminals and one neutral terminal be provided, again the presence of neutral terminal depends upon the type of secondary winding connection.
3	The size of a single-phase transformer is small.	A three-phase transformer is relatively larger in size.
4	A single-phase transformer cannot be used for supplying a three-phase load.	A three-phase transformer can be used to supply both 1-phase and 3-phase loads.
5	No specific winding configuration exists in case of a single-phase transformer.	The primary and secondary windings may be configured as follows. Delta – Delta (Δ - Δ) Delta – Star (Δ -Y) Star – Star (Y-Y) Star Delta (Y- Δ)
6	It costs less.	Cost is little bit higher

7 Single-phase transformers are used for small loads such as to supply single-domestic loads like pumps and lightings, etc., used in various electronic devices like in TVs, mobile chargers, etc. for voltage regulation, in home inverters for stepping up voltage, etc.

Three-phase transformers are used for supplying high power single-phase as well as three-phase loads as induction motors, etc. Also used in power systems for power transmission and distribution