

## Flat Belt Drives

1. Introduction.
2. Selection of a Belt Drive.
3. Types of Belt Drives.
4. Types of Belts.
5. Material used for Belts.
6. Working Stresses in Belts.
7. Density of Belt Materials.
8. Belt Speed.
9. Coefficient of Friction Between Belt and Pulley
10. Standard Belt Thicknesses and Widths.
11. Belt Joints.
12. Types of Flat Belt Drives.
13. Velocity Ratio of a Belt Drive.
14. Slip of the Belt.
15. Creep of Belt.
16. Length of an Open Belt Drive.
17. Length of a Cross Belt Drive.
18. Power transmitted by a Belt.
19. Ratio of Driving Tensions for Flat Belt Drive.
20. Centrifugal Tension.
21. Maximum Tension in the Belt.
22. Condition for Transmission of Maximum Power.
23. Initial Tension in the Belt.



### 18.1 Introduction

The belts or \*ropes are used to transmit power from one shaft to another by means of pulleys which rotate at the same speed or at different speeds. The amount of power transmitted depends upon the following factors :

1. The velocity of the belt.
2. The tension under which the belt is placed on the pulleys.
3. The arc of contact between the belt and the smaller pulley.
4. The conditions under which the belt is used.

It may be noted that

- (a) The shafts should be properly in line to insure uniform tension across the belt section.
- (b) The pulleys should not be too close together, in order that the arc of contact on the smaller pulley may be as large as possible.

\* Rope drives are discussed in Chapter 20.

- (c) The pulleys should not be so far apart as to cause the belt to weigh heavily on the shafts, thus increasing the friction load on the bearings.
- (d) A long belt tends to swing from side to side, causing the belt to run out of the pulleys, which in turn develops crooked spots in the belt.
- (e) The tight side of the belt should be at the bottom, so that whatever sag is present on the loose side will increase the arc of contact at the pulleys.
- (f) In order to obtain good results with flat belts, the maximum distance between the shafts should not exceed 10 metres and the minimum should not be less than 3.5 times the diameter of the larger pulley.

### 18.2 Selection of a Belt Drive

Following are the various important factors upon which the selection of a belt drive depends:

1. Speed of the driving and driven shafts,
2. Speed reduction ratio,
3. Power to be transmitted,
4. Centre distance between the shafts,
5. Positive drive requirements,
6. Shafts layout,
7. Space available, and
8. Service conditions.

### 18.3 Types of Belt Drives

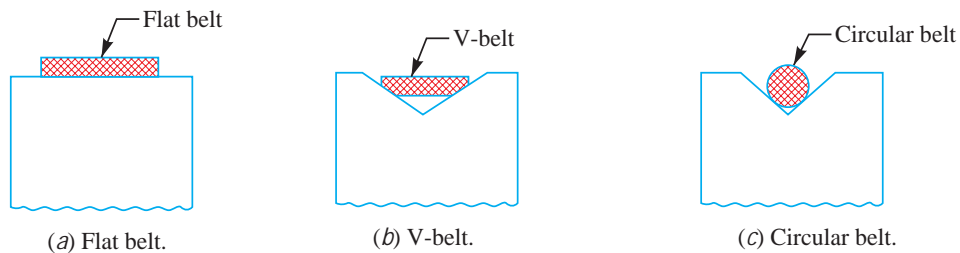
The belt drives are usually classified into the following three groups:

1. **Light drives.** These are used to transmit small powers at belt speeds upto about 10 m/s as in agricultural machines and small machine tools.
2. **Medium drives.** These are used to transmit medium powers at belt speeds over 10 m/s but up to 22 m/s, as in machine tools.
3. **Heavy drives.** These are used to transmit large powers at belt speeds above 22 m/s as in compressors and generators.

### 18.4 Types of Belts

Though there are many types of belts used these days, yet the following are important from the subject point of view:

1. **Flat belt.** The flat belt as shown in Fig. 18.1 (a), is mostly used in the factories and workshops, where a moderate amount of power is to be transmitted, from one pulley to another when the two pulleys are not more than 8 metres apart.



**Fig. 18.1.** Types of belts

2. **V-belt.** The V-belt as shown in Fig. 18.1 (b), is mostly used in the factories and workshops, where a great amount of power is to be transmitted, from one pulley to another, when the two pulleys are very near to each other.

3. **Circular belt or rope.** The circular belt or rope as shown in Fig. 18.1 (c) is mostly used in the factories and workshops, where a great amount of power is to be transmitted, from one pulley to another, when the two pulleys are more than 8 metres apart.

If a huge amount of power is to be transmitted, then a single belt may not be sufficient. In such a case, wide pulleys (for V-belts or circular belts) with a number of grooves are used. Then a belt in each groove is provided to transmit the required amount of power from one pulley to another.

**Note :** The V-belt and rope drives are discussed in Chapter 20.

### 18.5 Material used for Belts

The material used for belts and ropes must be strong, flexible, and durable. It must have a high coefficient of friction. The belts, according to the material used, are classified as follows:

**1. Leather belts.** The most important material for flat belt is leather. The best leather belts are made from 1.2 metres to 1.5 metres long strips cut from either side of the back bone of the top grade steer hides. The hair side of the leather is smoother and harder than the flesh side, but the flesh side is stronger. The fibres on the hair side are perpendicular to the surface, while those on the flesh side are interwoven and parallel to the surface. Therefore for these reasons the hair side of a belt should be in contact with the pulley surface as shown in Fig. 18.2. This gives a more intimate contact between belt and pulley and places the greatest tensile strength of the belt section on the outside, where the tension is maximum as the belt passes over the pulley.

The leather may be either oak-tanned or mineral salt-tanned *e.g.* chrome-tanned. In order to increase the thickness of belt, the strips are cemented together. The belts are specified according to the number of layers *e.g.* single, double or triple ply and according to the thickness of hides used *e.g.* light, medium or heavy.



**Fig. 18.2.** Leather belts.

The leather belts must be periodically cleaned and dressed or treated with a compound or dressing containing neats foot or other suitable oils so that the belt will remain soft and flexible.

**2. Cotton or fabric belts.** Most of the fabric belts are made by folding convass or cotton duck to three or more layers (depending upon the thickness desired) and stitching together. These belts are woven also into a strip of the desired width and thickness. They are impregnated with some filler like linseed oil in order to make the belt water-proof and to prevent injury to the fibres. The cotton belts are cheaper and suitable in warm climates, in damp atmospheres and in exposed positions. Since the cotton belts require little attention, therefore these belts are mostly used in farm machinery, belt conveyor etc.

**3. Rubber belt.** The rubber belts are made of layers of fabric impregnated with rubber composition and have a thin layer of rubber on the faces. These belts are very flexible but are quickly destroyed if allowed to come into contact with heat, oil or grease. One of the principle advantage of these belts is that they may be easily made endless. These belts are found suitable for saw mills, paper mills where they are exposed to moisture.

**4. Balata belts.** These belts are similar to rubber belts except that balata gum is used in place of rubber. These belts are acid proof and water proof and it is not effected by animal oils or alkalies. The balata belts should not be at temperatures above 40°C because at this temperature the balata begins to soften and becomes sticky. The strength of balata belts is 25 per cent higher than rubber belts.

### 18.6 Working Stresses in Belts

The ultimate strength of leather belt varies from 21 to 35 MPa and a factor of safety may be taken as 8 to 10. However, the wear life of a belt is more important than actual strength. It has been shown by experience that under average conditions an allowable stress of 2.8 MPa or less will give a reasonable belt life. An allowable stress of 1.75 MPa may be expected to give a belt life of about 15 years.

### 18.7 Density of Belt Materials

The density of various belt materials are given in the following table.

**Table 18.1. Density of belt materials.**

Material of belt	Mass density in kg / m <sup>3</sup>
Leather	1000
Convass	1220
Rubber	1140
Balata	1110
Single woven belt	1170
Double woven belt	1250

### 18.8 Belt Speed

A little consideration will show that when the speed of belt increases, the centrifugal force also increases which tries to pull the belt away from the pulley. This will result in the decrease of power transmitted by the belt. It has been found that for the efficient transmission of power, the belt speed 20 m/s to 22.5 m/s may be used.

### 18.9 Coefficient of Friction Between Belt and Pulley

The coefficient of friction between the belt and the pulley depends upon the following factors:

1. The material of belt;
2. The material of pulley;
3. The slip of belt; and
4. The speed of belt.

According to C.G. Barth, the coefficient of friction ( $\mu$ ) for oak tanned leather belts on cast iron pulley, at the point of slipping, is given by the following relation, *i.e.*

$$\mu = 0.54 - \frac{42.6}{152.6 + v}$$

where  $v$  = Speed of the belt in metres per minute.

The following table shows the values of coefficient of friction for various materials of belt and pulley.



*Belts used to drive wheels*

Table 18.2. Coefficient of friction between belt and pulley.

Belt material	Pulley material						
	Cast iron, steel			Wood	Compressed paper	Leather face	Rubber face
	Dry	Wet	Greasy				
1. Leather oak tanned	0.25	0.2	0.15	0.3	0.33	0.38	0.40
2. Leather chrome tanned	0.35	0.32	0.22	0.4	0.45	0.48	0.50
3. Convass-stitched	0.20	0.15	0.12	0.23	0.25	0.27	0.30
4. Cotton woven	0.22	0.15	0.12	0.25	0.28	0.27	0.30
5. Rubber	0.30	0.18	—	0.32	0.35	0.40	0.42
6. Balata	0.32	0.20	—	0.35	0.38	0.40	0.42

### 18.10 Standard Belt Thicknesses and Widths

The standard flat belt thicknesses are 5, 6.5, 8, 10 and 12 mm. The preferred values of thicknesses are as follows:

- (a) 5 mm for nominal belt widths of 35 to 63 mm,
- (b) 6.5 mm for nominal belt widths of 50 to 140 mm,
- (c) 8 mm for nominal belt widths of 90 to 224 mm,
- (d) 10 mm for nominal belt widths of 125 to 400 mm, and
- (e) 12 mm for nominal belt widths of 250 to 600 mm.

The standard values of nominal belt widths are in R10 series, starting from 25 mm upto 63 mm and in R 20 series starting from 71 mm up to 600 mm. Thus, the standard widths will be 25, 32, 40, 50, 63, 71, 80, 90, 100, 112, 125, 140, 160, 180, 200, 224, 250, 280, 315, 355, 400, 450, 500, 560 and 600 mm.

### 18.11 Belt Joints

When the endless belts are not available, then the belts are cut from big rolls and the ends are joined together by fasteners. The various types of joints are

1. Cemented joint,
2. Laced joint, and
3. Hinged joint.

The **cemented joint**, as shown in Fig. 18.3 (a), made by the manufacturer to form an endless belt, is preferred than other joints. The **laced joint** is formed by punching holes in line across the belt, leaving a margin between the edge and the holes. A raw hide strip is used for lacing the two ends together to form a joint. This type of joint is known as *straight-stitch raw hide laced joint*, as shown in Fig. 18.3 (b).

Metal laced joint as shown in Fig. 18.3 (c), is made like a staple connection. The points are driven through the flesh side of the belt and clinched on the inside.

Sometimes, **metal hinges** may be fastened to the belt ends and connected by a steel or fibre pin as shown in Fig. 18.3 (d).

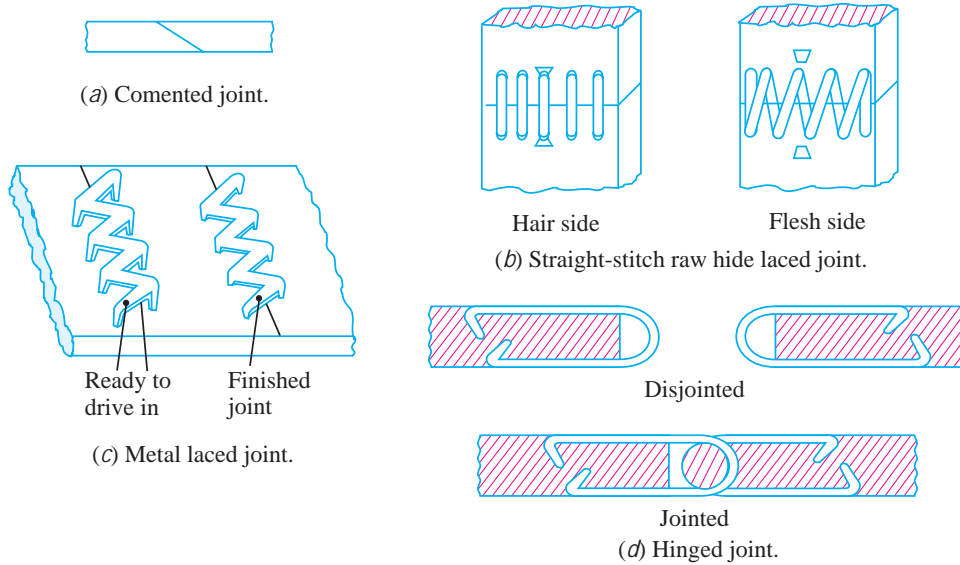


Fig. 18.3. Belt joints.

The following table shows the efficiencies of these joints.

Table 18.3. Efficiencies of belt joints.

Type of joint	Efficiency (%)	Type of joint	Efficiency (%)
1. Cemented, endless, cemented at factory	90 to 100	4. Wire laced by hand	70 to 80
2. Cemented in shop	80 to 90	5. Raw-hide laced	60 to 70
3. Wire laced by machine	75 to 85	6. Metal belt hooks	35 to 40

### 18.12 Types of Flat Belt Drives

The power from one pulley to another may be transmitted by any of the following types of belt drives.



Cross or twist belt drive

**1. Open belt drive.** The open belt drive, as shown in Fig. 18.4, is used with shafts arranged parallel and rotating in the same direction. In this case, the driver  $A$  pulls the belt from one side (*i.e.* lower side  $RQ$ ) and delivers it to the other side (*i.e.* upper side  $LM$ ). Thus the tension in the lower side belt (because of more tension) is known as **tight side** whereas the upper side belt (because of less tension) is known as **slack side**, as shown in Fig. 18.4.

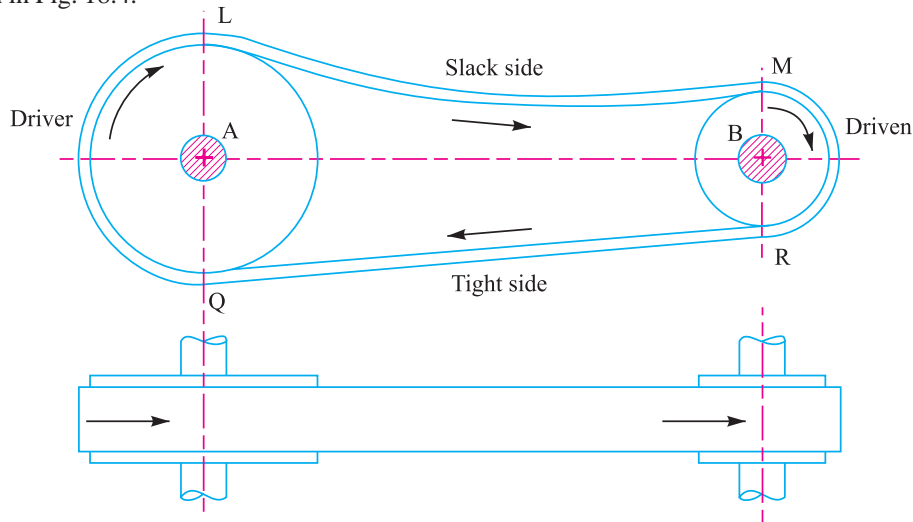


Fig. 18.4. Open belt drive.

**2. Crossed or twist belt drive.** The crossed or twist belt drive, as shown in Fig. 18.5, is used with shafts arranged parallel and rotating in the opposite directions. In this case, the driver pulls the belt from one side (*i.e.*  $RQ$ ) and delivers it to the other side (*i.e.*  $LM$ ). Thus, the tension in the belt  $RQ$  will be more than that in the belt  $LM$ . The belt  $RQ$  (because of more tension) is known as **tight side**, whereas the belt  $LM$  (because of less tension) is known as **slack side**, as shown in Fig. 18.5.

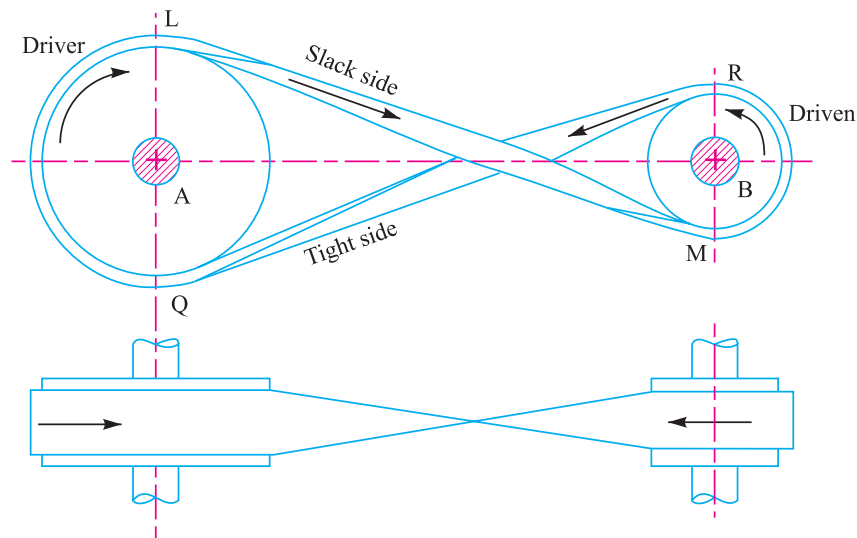


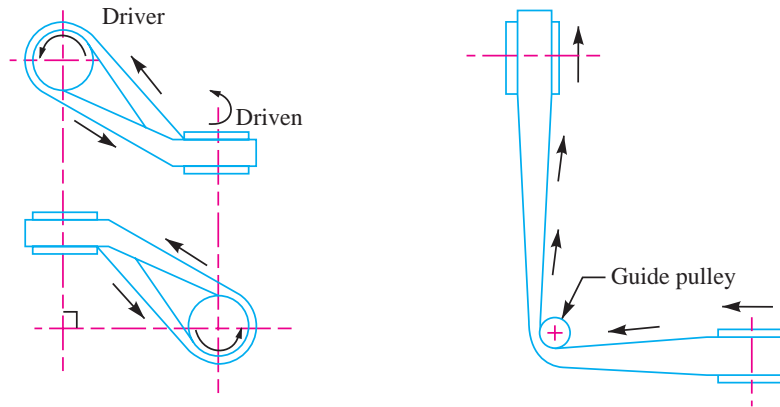
Fig. 18.5. Crossed or twist belt drive.

A little consideration will show that at a point where the belt crosses, it rubs against each other and there will be excessive wear and tear. In order to avoid this, the shafts should be placed at a

maximum distance of  $20b$ , where  $b$  is the width of belt and the speed of the belt should be less than 15 m/s.

**3. Quarter turn belt drive.** The quarter turn belt drive (also known as *right angle belt drive*) as shown in Fig. 18.6 (a), is used with shafts arranged at right angles and rotating in one definite direction. In order to prevent the belt from leaving the pulley, the width of the face of the pulley should be greater or equal to  $1.4b$ , where  $b$  is width of belt.

In case the pulleys cannot be arranged as shown in Fig. 18.6 (a) or when the reversible motion is desired, then a *quarter turn belt drive with a guide pulley*, as shown in Fig. 18.6 (b), may be used.



(a) Quarter turn belt drive.

(b) Quarter turn belt drive with guide pulley.

Fig. 18.6

**4. Belt drive with idler pulleys.** A belt drive with an idler pulley (also known as *jockey pulley drive*) as shown in Fig. 18.7, is used with shafts arranged parallel and when an open belt drive cannot be used due to small angle of contact on the smaller pulley. This type of drive is provided to obtain high velocity ratio and when the required belt tension cannot be obtained by other means.

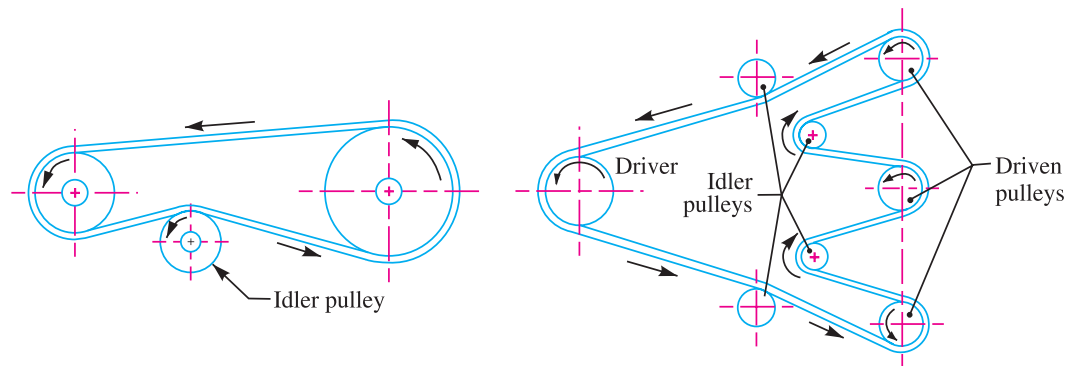


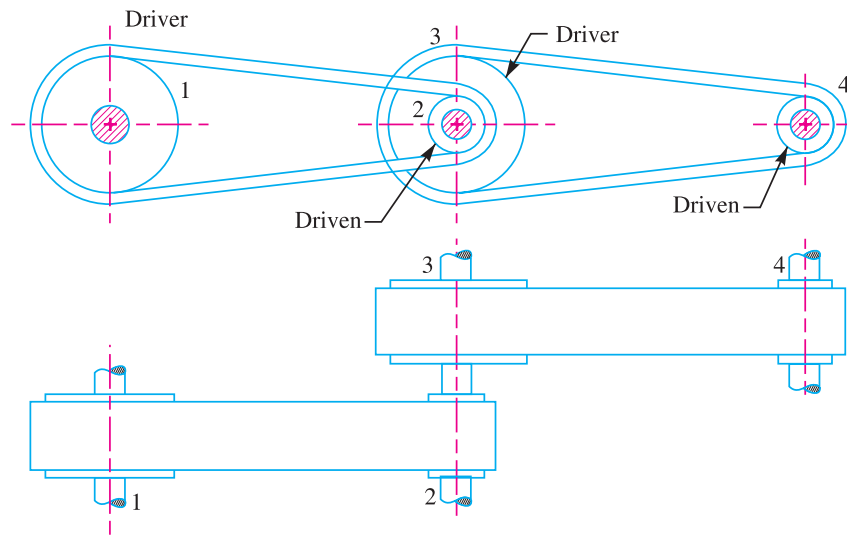
Fig. 18.7. Belt drive with single idler pulley.

Fig. 18.8. Belt drive with many idler pulleys.

When it is desired to transmit motion from one shaft to several shafts, all arranged in parallel, a belt drive with many idler pulleys, as shown in Fig. 18.8, may be employed.

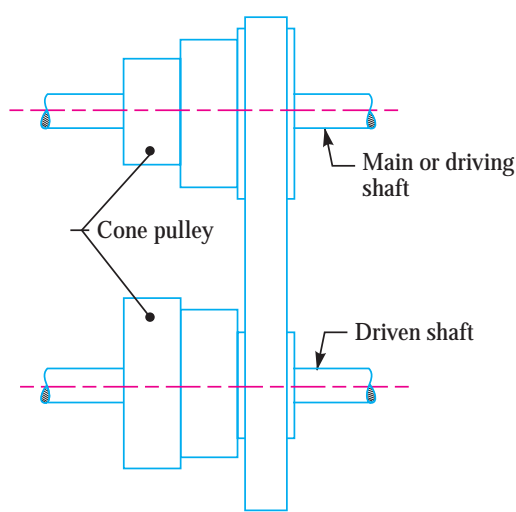
**5. Compound belt drive.** A compound belt drive as shown in Fig. 18.9, is used when power is transmitted from one shaft to another through a number of pulleys.



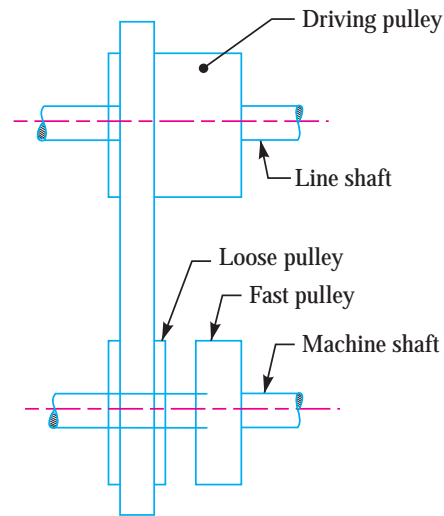


**Fig. 18.9.** Compound belt drive.

**6. Stepped or cone pulley drive.** A stepped or cone pulley drive, as shown in Fig. 18.10, is used for changing the speed of the driven shaft while the main or driving shaft runs at constant speed. This is accomplished by shifting the belt from one part of the steps to the other.



**Fig. 18.10.** Stepped or cone pulley drive.



**Fig. 18.11.** Fast and loose pulley drive.

**7. Fast and loose pulley drive.** A fast and loose pulley drive, as shown in Fig. 18.11, is used when the driven or machine shaft is to be started or stopped whenever desired without interfering with the driving shaft. A pulley which is keyed to the machine shaft is called fast pulley and runs at the same speed as that of machine shaft. A loose pulley runs freely over the machine shaft and is incapable of transmitting any power. When the driven shaft is required to be stopped, the belt is pushed on to the loose pulley by means of sliding bar having belt forks.

### 18.13 Velocity Ratio of a Belt Drive

It is the ratio between the velocities of the driver and the follower or driven. It may be expressed, mathematically, as discussed below:

Let  $d_1$  = Diameter of the driver,  
 $d_2$  = Diameter of the follower,  
 $N_1$  = Speed of the driver in r.p.m.,  
 $N_2$  = Speed of the follower in r.p.m.,

∴ Length of the belt that passes over the driver, in one minute  
 $= \pi d_1 N_1$

Similarly, length of the belt that passes over the follower, in one minute  
 $= \pi d_2 N_2$

Since the length of belt that passes over the driver in one minute is equal to the length of belt that passes over the follower in one minute, therefore

$$\therefore \pi d_1 N_1 = \pi d_2 N_2$$

and velocity ratio,  $\frac{N_2}{N_1} = \frac{d_1}{d_2}$

When thickness of the belt ( $t$ ) is considered, then velocity ratio,

$$\frac{N_2}{N_1} = \frac{d_1 + t}{d_2 + t}$$

**Notes : 1.** The velocity ratio of a belt drive may also be obtained as discussed below:

We know that the peripheral velocity of the belt on the driving pulley,

$$v_1 = \frac{\pi d_1 N_1}{60} \text{ m/s}$$

and peripheral velocity of the belt on the driven pulley,

$$v_2 = \frac{\pi d_2 N_2}{60} \text{ m/s}$$

When there is no slip, then  $v_1 = v_2$ .

$$\therefore \frac{\pi d_1 N_1}{60} = \frac{\pi d_2 N_2}{60} \text{ or } \frac{N_2}{N_1} = \frac{d_1}{d_2}$$

**2.** In case of a compound belt drive as shown in Fig. 18.7, the velocity ratio is given by

$$\frac{N_4}{N_1} = \frac{d_1 \times d_3}{d_2 \times d_4} \text{ or } \frac{\text{Speed of last driven}}{\text{Speed of first driver}} = \frac{\text{Product of diameters of drivers}}{\text{Product of diameters of drivens}}$$

### 18.14 Slip of the Belt

In the previous articles we have discussed the motion of belts and pulleys assuming a firm frictional grip between the belts and the pulleys. But sometimes, the frictional grip becomes insufficient. This may cause some forward motion of the driver without carrying the belt with it. This is called *slip of the belt* and is generally expressed as a percentage.

The result of the belt slipping is to reduce the velocity ratio of the system. As the slipping of the belt is a common phenomenon, thus the belt should never be used where a definite velocity ratio is of importance (as in the case of hour, minute and second arms in a watch).

Let  $s_1$  % = Slip between the driver and the belt, and  
 $s_2$  % = Slip between the belt and follower,

∴ Velocity of the belt passing over the driver per second,

$$v = \frac{\pi d_1 N_1}{60} - \frac{\pi d_1 N_1}{60} \times \frac{s_1}{100}$$

$$= \frac{\pi d_1 N_1}{60} \left(1 - \frac{s_1}{100}\right) \quad \dots(i)$$

and velocity of the belt passing over the follower per second

$$\frac{\pi d_2 N_2}{60} = v - v \left(\frac{s_2}{100}\right) = v \left(1 - \frac{s_2}{100}\right)$$

Substituting the value of v from equation (i), we have

$$\frac{\pi d_2 N_2}{60} = \frac{\pi d_1 N_1}{60} \left(1 - \frac{s_1}{100}\right) \left(1 - \frac{s_2}{100}\right)$$

$$\therefore \frac{N_2}{N_1} = \frac{d_1}{d_2} \left(1 - \frac{s_1}{100} - \frac{s_2}{100}\right) \quad \dots \left(\text{Neglecting } \frac{s_1 \times s_2}{100 \times 100}\right)$$

$$= \frac{d_1}{d_2} \left[1 - \left(\frac{s_1 + s_2}{100}\right)\right] = \frac{d_1}{d_2} \left(1 - \frac{s}{100}\right)$$

...(where  $s = s_1 + s_2$  i.e. total percentage of slip)

If thickness of the belt ( $t$ ) is considered, then

$$\frac{N_2}{N_1} = \frac{d_1 + t}{d_2 + t} \left(1 - \frac{s}{100}\right)$$

### 18.15 Creep of Belt

When the belt passes from the slack side to the tight side, a certain portion of the belt extends and it contracts again when the belt passes from the tight side to the slack side. Due to these changes of length, there is a relative motion between the belt and the pulley surfaces. This relative motion is termed as **creep**. The total effect of creep is to reduce slightly the speed of the driven pulley or follower. Considering creep, the velocity ratio is given by

$$\frac{N_2}{N_1} = \frac{d_1}{d_2} \times \frac{E + \sqrt{\sigma_2}}{E + \sqrt{\sigma_1}}$$

where  $\sigma_1$  and  $\sigma_2$  = Stress in the belt on the tight and slack side respectively, and  $E$  = Young's modulus for the material of the belt.

**Note:** Since the effect of creep is very small, therefore it is generally neglected.

**Example 18.1.** An engine running at 150 r.p.m. drives a line shaft by means of a belt. The engine pulley is 750 mm diameter and the pulley on the line shaft is 450 mm. A 900 mm diameter pulley on the line shaft drives a 150 mm diameter pulley keyed to a dynamo shaft. Find the speed of dynamo shaft, when 1. there is no slip, and 2. there is a slip of 2% at each drive.

**Solution.** Given :  $N_1 = 150$  r.p.m. ;  $d_1 = 750$  mm ;  $d_2 = 450$  mm ;  $d_3 = 900$  mm ;  $d_4 = 150$  mm ;  $s_1 = s_2 = 2\%$

The arrangement of belt drive is shown in Fig. 18.12.



Belt slip indicator is used to indicate that the belt is slipping.

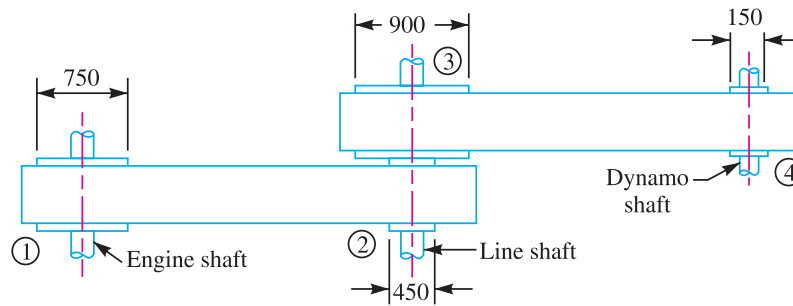
Let  $N_4$  = Speed of the dynamo shaft.

**1. When there is no slip**

We know that

$$\frac{N_4}{N_1} = \frac{d_1 \times d_3}{d_2 \times d_4} \text{ or } \frac{N_4}{150} = \frac{750 \times 900}{450 \times 150} = 10$$

$\therefore N_4 = 150 \times 10 = 1500 \text{ r.p.m. Ans.}$



All dimensions in mm.

Fig. 18.12

**2. When there is a slip of 2% at each drive**

We know that

$$\frac{N_4}{N_1} = \frac{d_1 \times d_3}{d_2 \times d_4} \left(1 - \frac{s_1}{100}\right) \left(1 - \frac{s_2}{100}\right)$$

or  $\frac{N_4}{150} = \frac{750 \times 900}{450 \times 150} \left(1 - \frac{2}{100}\right) \left(1 - \frac{2}{100}\right) = 9.6$

$\therefore N_4 = 150 \times 9.6 = 1440 \text{ r.p.m. Ans.}$

**18.16 Length of an Open Belt Drive**

We have discussed in Art. 18.12, that in an open belt drive, both the pulleys rotate in the same direction as shown in Fig. 18.13.

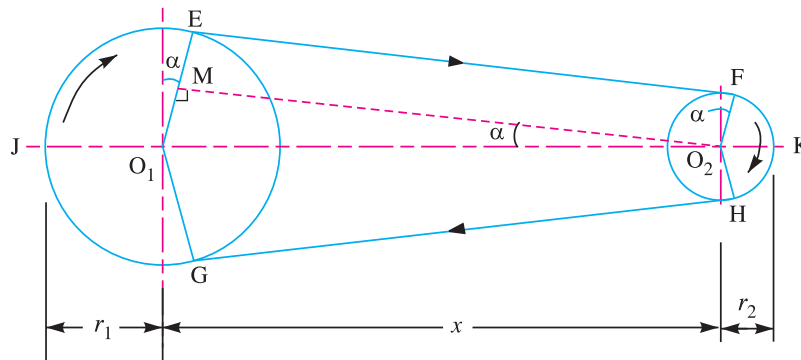


Fig. 18.13. Open belt drive.

Let  $r_1$  and  $r_2$  = Radii of the larger and smaller pulleys,  
 $x$  = Distance between the centres of two pulleys (i.e.  $O_1O_2$ ), and  
 $L$  = Total length of the belt.

Let the belt leaves the larger pulley at  $E$  and  $G$  and the smaller pulley at  $F$  and  $H$  as shown in Fig. 18.13. Through  $O_2$  draw  $O_2M$  parallel to  $FE$ .

From the geometry of the figure, we find that  $O_2M$  will be perpendicular to  $O_1E$ .

Let the angle  $MO_2O_1 = \alpha$  radians.

We know that the length of the belt,

$$\begin{aligned} L &= \text{Arc } GJE + EF + \text{Arc } FKH + HG \\ &= 2 (\text{Arc } JE + EF + \text{Arc } FK) \end{aligned} \quad \dots(i)$$

From the geometry of the figure, we also find that

$$\sin \alpha = \frac{O_1M}{O_1O_2} = \frac{O_1E - EM}{O_1O_2} = \frac{r_1 - r_2}{x}$$

Since the angle  $\alpha$  is very small, therefore putting

$$\sin \alpha = \alpha \text{ (in radians)} = \frac{r_1 - r_2}{x} \quad \dots(ii)$$

$$\therefore \text{Arc } JE = r_1 \left( \frac{\pi}{2} + \alpha \right) \quad \dots(iii)$$

$$\text{Similarly, arc } FK = r_2 \left( \frac{\pi}{2} - \alpha \right) \quad \dots(iv)$$

and

$$\begin{aligned} EF &= MO_2 = \sqrt{(O_1O_2)^2 - (O_1M)^2} = \sqrt{x^2 - (r_1 - r_2)^2} \\ &= x \sqrt{1 - \left( \frac{r_1 - r_2}{x} \right)^2} \end{aligned}$$

Expanding this equation by binomial theorem, we have

$$EF = x \left[ 1 - \frac{1}{2} \left( \frac{r_1 - r_2}{x} \right)^2 + \dots \right] = x - \frac{(r_1 - r_2)^2}{2x} \quad \dots(v)$$

Substituting the values of arc  $JE$  from equation (iii), arc  $FK$  from equation (iv) and  $EF$  from equation (v) in equation (i), we get

$$\begin{aligned} L &= 2 \left[ r_1 \left( \frac{\pi}{2} + \alpha \right) + x - \frac{(r_1 - r_2)^2}{2x} + r_2 \left( \frac{\pi}{2} - \alpha \right) \right] \\ &= 2 \left[ r_1 \times \frac{\pi}{2} + r_1 \alpha + x - \frac{(r_1 - r_2)^2}{2x} + r_2 \times \frac{\pi}{2} - r_2 \alpha \right] \\ &= 2 \left[ \frac{\pi}{2} (r_1 + r_2) + \alpha (r_1 - r_2) + x - \frac{(r_1 - r_2)^2}{2x} \right] \\ &= \pi (r_1 + r_2) + 2\alpha (r_1 - r_2) + 2x - \frac{(r_1 - r_2)^2}{x} \end{aligned}$$

Substituting the value of  $\alpha = \frac{(r_1 - r_2)}{x}$  from equation (ii), we get

$$\begin{aligned} L &= \pi (r_1 + r_2) + 2 \times \frac{(r_1 - r_2)}{x} (r_1 - r_2) + 2x - \frac{(r_1 - r_2)^2}{x} \\ &= \pi (r_1 + r_2) + \frac{2(r_1 - r_2)^2}{x} + 2x - \frac{(r_1 - r_2)^2}{x} \end{aligned}$$

$$= \pi (r_1 + r_2) + 2x + \frac{(r_1 - r_2)^2}{x} \quad \dots \text{ (in terms of pulley radii)}$$

$$= \frac{\pi}{2} (d_1 + d_2) + 2x + \frac{(d_1 - d_2)^2}{4x} \quad \dots \text{ (in terms of pulley diameters)}$$

### 18.17 Length of a Cross Belt Drive

We have discussed in Art. 18.12 that in a cross belt drive, both the pulleys rotate in the opposite directions as shown in Fig. 18.14.

Let  $r_1$  and  $r_2$  = Radii of the larger and smaller pulleys,  
 $x$  = Distance between the centres of two pulleys (*i.e.*  $O_1O_2$ ), and  
 $L$  = Total length of the belt.

Let the belt leaves the larger pulley at  $E$  and  $G$  and the smaller pulley at  $F$  and  $H$  as shown in Fig. 18.14.

Through  $O_2$  draw  $O_2M$  parallel to  $FE$ .

From the geometry of the figure, we find that  $O_2M$  will be perpendicular to  $O_1E$ .

Let the angle  $MO_2O_1 = \alpha$  radians.

We know that the length of the belt,

$$L = \text{Arc } GJE + EF + \text{Arc } FKH + HG$$

$$= 2 (\text{Arc } JE + FE + \text{Arc } FK) \quad \dots(i)$$

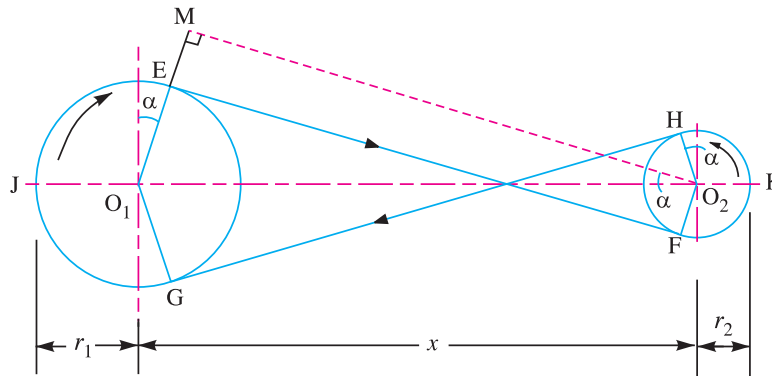


Fig. 18.14. Crossed belt drive.

From the geometry of the figure, we find that

$$\sin \alpha = \frac{O_1M}{O_1O_2} = \frac{O_1E + EM}{O_1O_2} = \frac{r_1 + r_2}{x}$$

Since the angle  $\alpha$  is very small, therefore putting

$$\sin \alpha = \alpha \text{ (in radians)} = \frac{r_1 + r_2}{x} \quad \dots(ii)$$

$$\therefore \text{Arc } JE = r_1 \left( \frac{\pi}{2} + \alpha \right) \quad \dots(iii)$$

$$\text{Similarly, arc } FK = r_2 \left( \frac{\pi}{2} + \alpha \right) \quad \dots(iv)$$

and

$$EF = MO_2 = \sqrt{(O_1O_2)^2 - (O_1M)^2} = \sqrt{x^2 - (r_1 + r_2)^2}$$

$$= x \sqrt{1 - \left(\frac{r_1 + r_2}{x}\right)^2}$$

Expanding this equation by binomial theorem, we have

$$EF = x \left[ 1 - \frac{1}{2} \left(\frac{r_1 + r_2}{x}\right)^2 + \dots \right] = x - \frac{(r_1 + r_2)^2}{2x} \quad \dots(v)$$



In the above conveyor belt is used to transport material as well as to drive the rollers

Substituting the values of arc  $JE$  from equation (iii), arc  $FK$  from equation (iv) and  $EF$  from equation (v) in equation (i), we get,

$$L = 2 \left[ r_1 \left( \frac{\pi}{2} + \alpha \right) + x - \frac{(r_1 + r_2)^2}{2x} + r_2 \left( \frac{\pi}{2} + \alpha \right) \right]$$

$$= 2 \left[ r_1 \times \frac{\pi}{2} + r_1 \alpha + x - \frac{(r_1 + r_2)^2}{2x} + r_2 \times \frac{\pi}{2} + r_2 \alpha \right]$$

$$= 2 \left[ \frac{\pi}{2} (r_1 + r_2) + \alpha (r_1 + r_2) + x - \frac{(r_1 + r_2)^2}{2x} \right]$$

$$= \pi (r_1 + r_2) + 2\alpha (r_1 + r_2) + 2x - \frac{(r_1 + r_2)^2}{x}$$

Substituting the value of  $\alpha = \frac{(r_1 + r_2)}{x}$  from equation (ii), we get

$$L = \pi (r_1 + r_2) + 2 \times \frac{(r_1 + r_2)}{x} (r_1 + r_2) + 2x - \frac{(r_1 + r_2)^2}{x}$$

$$= \pi (r_1 + r_2) + \frac{2 (r_1 + r_2)^2}{x} + 2x - \frac{(r_1 + r_2)^2}{x}$$

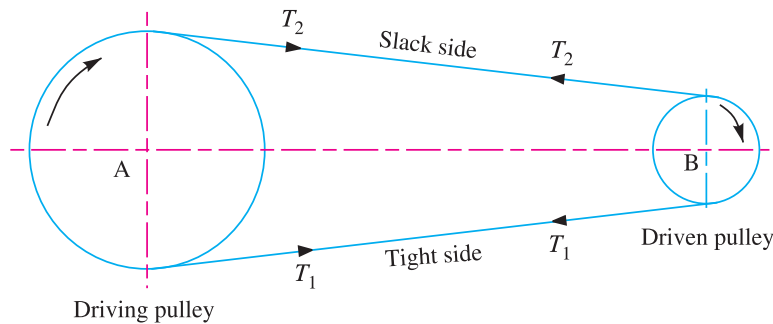
$$= \pi (r_1 + r_2) + 2x + \frac{(r_1 + r_2)^2}{x} \quad \dots \text{ (in terms of pulley radii)}$$

$$= \frac{\pi}{2} (d_1 + d_2) + 2x + \frac{(d_1 + d_2)^2}{4x} \quad \dots \text{ (in terms of pulley diameters)}$$

It may be noted that the above expression is a function of  $(r_1 + r_2)$ . It is thus obvious, that if sum of the radii of the two pulleys be constant, length of the belt required will also remain constant, provided the distance between centres of the pulleys remain unchanged.

### 18.18 Power Transmitted by a Belt

Fig. 18.15 shows the driving pulley (or driver) A and the driven pulley (or follower) B. As already discussed, the driving pulley pulls the belt from one side and delivers it to the other side. It is thus obvious that the tension on the former side (*i.e.* tight side) will be greater than the latter side (*i.e.* slack side) as shown in Fig. 18.15.



**Fig. 18.15.** Power transmitted by a belt.

Let  $T_1$  and  $T_2$  = Tensions in the tight side and slack side of the belt respectively in newtons,  
 $r_1$  and  $r_2$  = Radii of the driving and driven pulleys respectively in metres,  
 and  $v$  = Velocity of the belt in m/s.

The effective turning (driving) force at the circumference of the driven pulley or follower is the difference between the two tensions (*i.e.*  $T_1 - T_2$ ).



*This massive shaft-like pulley drives the conveyor belt.*



∴ Work done per second =  $(T_1 - T_2) v$  N-m/s  
 and power transmitted =  $(T_1 - T_2) v W$  ... ( $\because 1 \text{ N-m/s} = 1 W$ )

A little consideration will show that torque exerted on the driving pulley is  $(T_1 - T_2) r_1$ .  
 Similarly, the torque exerted on the driven pulley is  $(T_1 - T_2) r_2$ .

### 18.19 Ratio of Driving Tensions for Flat Belt Drive

Consider a driven pulley rotating in the clockwise direction as shown in Fig. 18.16.

- Let
- $T_1$  = Tension in the belt on the tight side,
  - $T_2$  = Tension in the belt on the slack side, and
  - $\theta$  = Angle of contact in radians (*i.e.* angle subtended by the arc AB, along which the belt touches the pulley, at the centre).

Now consider a small portion of the belt PQ, subtending an angle  $\delta\theta$  at the centre of the pulley as shown in Fig. 18.16. The belt PQ is in equilibrium under the following forces:

1. Tension  $T$  in the belt at P,
  2. Tension  $(T + \delta T)$  in the belt at Q,
  3. Normal reaction  $R_N$ , and
  4. Frictional force  $F = \mu \times R_N$ ,
- where  $\mu$  is the coefficient of friction between the belt and pulley.

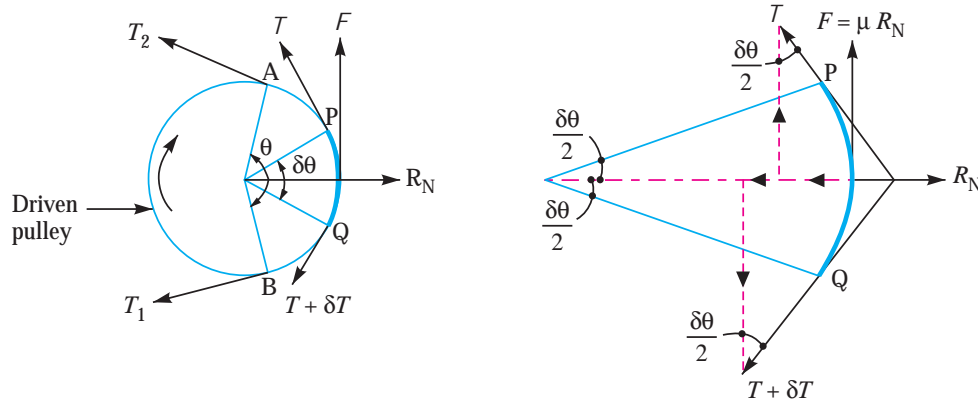


Fig. 18.16. Ratio of driving tensions for flat belt.

Resolving all the forces horizontally, we have

$$R_N = (T + \delta T) \sin \frac{\delta\theta}{2} + T \sin \frac{\delta\theta}{2} \quad \dots(i)$$

Since the angle  $\delta\theta$  is very small, therefore putting  $\sin \delta\theta/2 = \delta\theta/2$  in equation (i), we have

$$\begin{aligned} R_N &= (T + \delta T) \frac{\delta\theta}{2} + T \frac{\delta\theta}{2} = \frac{T \cdot \delta\theta}{2} + \frac{\delta T \cdot \delta\theta}{2} + \frac{T \cdot \delta\theta}{2} \\ &= T \cdot \delta\theta \quad \dots \left( \text{Neglecting } \frac{\delta T \cdot \delta\theta}{2} \right) \quad \dots(ii) \end{aligned}$$

Now resolving the forces vertically, we have

$$\mu \times R_N = (T + \delta T) \cos \frac{\delta\theta}{2} - T \cos \frac{\delta\theta}{2} \quad \dots(iii)$$

Since the angle  $\delta\theta$  is very small, therefore putting  $\cos \delta\theta/2 = 1$  in equation (iii), we have

$$\mu \times R_N = T + \delta T - T = \delta T \quad \text{or} \quad R_N = \frac{\delta T}{\mu} \quad \dots(iv)$$

**694 ■ A Textbook of Machine Design**

Equating the values of  $R_N$  from equations (ii) and (iv), we get

$$T \cdot \delta\theta = \frac{\delta T}{\mu} \quad \text{or} \quad \frac{\delta T}{T} = \mu \cdot \delta\theta$$

Integrating the above equation between the limits  $T_2$  and  $T_1$  and from 0 to  $\theta$ , we have

$$\int_{T_2}^{T_1} \frac{\delta T}{T} = \mu \int_0^\theta \delta\theta$$

$$\therefore \log_e \left( \frac{T_1}{T_2} \right) = \mu \cdot \theta \quad \text{or} \quad \frac{T_1}{T_2} = e^{\mu \cdot \theta} \quad \dots (v)$$

The equation (v) can be expressed in terms of corresponding logarithm to the base 10, i.e.

$$2.3 \log \left( \frac{T_1}{T_2} \right) = \mu \cdot \theta$$

The above expression gives the relation between the tight side and slack side tensions, in terms of coefficient of friction and the angle of contact.

**Notes : 1.** While determining the angle of contact, it must be remembered that it is the angle of contact at the smaller pulley, if both the pulleys are of the same material. We know that

$$\sin \alpha = \frac{r_1 - r_2}{x} \quad \dots \text{(for open belt drive)}$$

$$= \frac{r_1 + r_2}{x} \quad \dots \text{(for cross-belt drive)}$$

$\therefore$  Angle of contact or lap,

$$\theta = (180^\circ - 2\alpha) \frac{\pi}{180} \text{ rad} \quad \dots \text{(for open belt drive)}$$

$$= (180^\circ + 2\alpha) \frac{\pi}{180} \text{ rad} \quad \dots \text{(for cross-belt drive)}$$

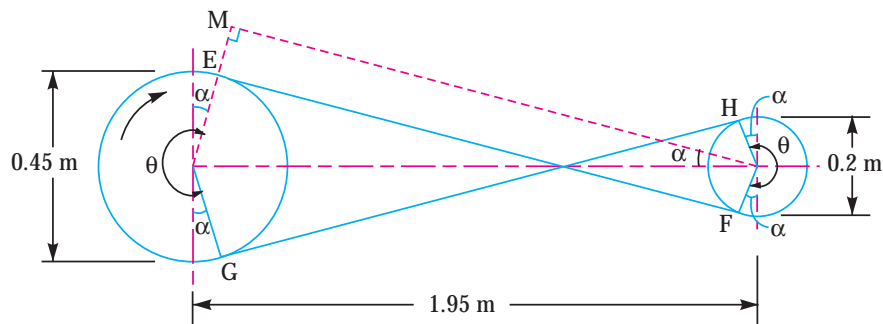
**2.** When the pulleys are made of different material (i.e. when the coefficient of friction of the pulleys or the angle of contact are different), then the design will refer to the pulley for which  $\mu \cdot \theta$  is small.

**Example 18.2.** Two pulleys, one 450 mm diameter and the other 200 mm diameter, on parallel shafts 1.95 m apart are connected by a crossed belt. Find the length of the belt required and the angle of contact between the belt and each pulley.

What power can be transmitted by the belt when the larger pulley rotates at 200 rev/min, if the maximum permissible tension in the belt is 1 kN, and the coefficient of friction between the belt and pulley is 0.25?

**Solution.** Given :  $d_1 = 450 \text{ mm} = 0.45 \text{ m}$  or  $r_1 = 0.225 \text{ m}$  ;  $d_2 = 200 \text{ mm} = 0.2 \text{ m}$  or  $r_2 = 0.1 \text{ m}$  ;  $x = 1.95 \text{ m}$  ;  $N_1 = 200 \text{ r.p.m.}$  ;  $T_1 = 1 \text{ kN} = 1000 \text{ N}$  ;  $\mu = 0.25$

The arrangement of crossed belt drive is shown in Fig. 18.17.



**Fig. 18.17**

**Length of the belt**

We know that length of the belt,

$$L = \pi (r_1 + r_2) + 2x + \frac{(r_1 + r_2)^2}{x}$$

$$= \pi (0.225 + 0.1) + 2 \times 1.95 + \frac{(0.225 + 0.1)^2}{1.95}$$

$$= 1.02 + 3.9 + 0.054 = 4.974 \text{ m Ans.}$$

**Angle of contact between the belt and each pulley**

Let  $\theta$  = Angle of contact between the belt and each pulley.

We know that for a crossed belt drive,

$$\sin \alpha = \frac{r_1 + r_2}{x} = \frac{0.225 + 0.1}{1.95} = 0.1667$$

$\therefore \alpha = 9.6^\circ$

and  $\theta = 180^\circ + 2\alpha = 180 + 2 \times 9.6 = 199.2^\circ$

$$= 199.2 \times \frac{\pi}{180} = 3.477 \text{ rad Ans.}$$

**Power transmitted**

Let  $T_1$  = Tension in the tight side of the belt, and  
 $T_2$  = Tension in the slack side of the belt.

We know that

$$2.3 \log \left( \frac{T_1}{T_2} \right) = \mu \cdot \theta = 0.25 \times 3.477 = 0.8693$$

$$\log \left( \frac{T_1}{T_2} \right) = \frac{0.8693}{2.3} = 0.378 \text{ or } \frac{T_1}{T_2} = 2.387 \quad \dots \text{ (Taking antilog of 0.378)}$$

$\therefore T_2 = \frac{T_1}{2.387} = \frac{1000}{2.387} = 419 \text{ N}$

We know that the velocity of belt,

$$v = \frac{\pi d_1 N_1}{60} = \frac{\pi \times 0.45 \times 200}{60} = 4.713 \text{ m/s}$$

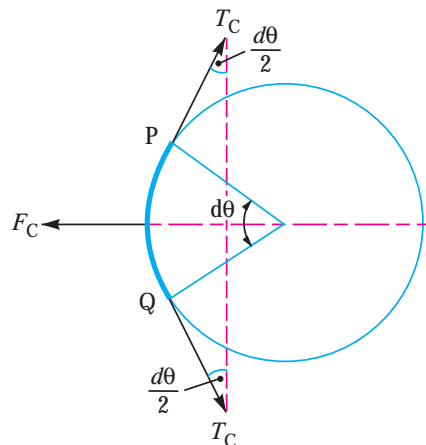
$\therefore$  Power transmitted,

$$P = (T_1 - T_2) v = (1000 - 419) 4.713 = 2738 \text{ W} = 2.738 \text{ kW Ans.}$$

**18.20 Centrifugal Tension**

Since the belt continuously runs over the pulleys, therefore, some centrifugal force is caused, whose effect is to increase the tension on both the tight as well as the slack sides. The tension caused by centrifugal force is called **centrifugal tension**. At lower belt speeds (less than 10 m/s), the centrifugal tension is very small, but at higher belt speeds (more than 10 m/s), its effect is considerable and thus should be taken into account.

Consider a small portion  $PQ$  of the belt subtending an angle  $d\theta$  at the centre of the pulley, as shown in Fig. 18.18.



**Fig. 18.18.** Centrifugal tension.

## 696 ■ A Textbook of Machine Design

Let  $m$  = Mass of belt per unit length in kg,  
 $v$  = Linear velocity of belt in m/s,  
 $r$  = Radius of pulley over which the belt runs in metres, and  
 $T_C$  = Centrifugal tension acting tangentially at  $P$  and  $Q$  in newtons.

We know that length of the belt  $PQ$

$$= r.d\theta$$

and mass of the belt  $PQ$  =  $m.r.d\theta$

∴ Centrifugal force acting on the belt  $PQ$ ,

$$F_C = m.r.d\theta \times \frac{v^2}{r} = m.d\theta.v^2$$



*Belt drive on a lathe*

The centrifugal tension  $T_C$  acting tangentially at  $P$  and  $Q$  keeps the belt in equilibrium. Now resolving the forces (*i.e.* centrifugal force and centrifugal tension) horizontally, we have

$$T_C \sin\left(\frac{d\theta}{2}\right) + T_C \sin\left(\frac{d\theta}{2}\right) = F_C = m.d\theta.v^2 \quad \dots(i)$$

Since the angle  $d\theta$  is very small, therefore putting  $\sin\left(\frac{d\theta}{2}\right) = \frac{d\theta}{2}$  in equation (i), we have

$$2T_C\left(\frac{d\theta}{2}\right) = m.d\theta.v^2$$

$$\therefore T_C = m.v^2$$

**Notes : 1.** When centrifugal tension is taken into account, then total tension in the tight side,

$$T_{t1} = T_1 + T_C$$

and total tension in the slack side,

$$T_{t2} = T_2 + T_C$$

2. Power transmitted,

$$P = (T_{t1} - T_{t2}) v \quad \dots(\text{in watts})$$

$$= [(T_1 + T_C) - (T_2 + T_C)]v = (T_1 - T_2) v \quad \dots (\text{same as before})$$

Thus we see that the centrifugal tension has no effect on the power transmitted.

3. The ratio of driving tensions may also be written as

$$2.3 \log \left( \frac{T_{t1} - T_C}{T_{t2} - T_C} \right) = \mu \cdot \theta$$

where  $T_{t1}$  = Maximum or total tension in the belt.

### 18.21 Maximum Tension in the Belt

A little consideration will show that the maximum tension in the belt ( $T$ ) is equal to the total tension in the tight side of the belt ( $T_{t1}$ ).

Let  $\sigma$  = Maximum safe stress,  
 $b$  = Width of the belt, and  
 $t$  = Thickness of the belt.

We know that the maximum tension in the belt,

$$T = \text{Maximum stress} \times \text{Cross-sectional area of belt} = \sigma \cdot b \cdot t$$

When centrifugal tension is neglected, then

$$T \text{ (or } T_{t1}) = T_1, \text{ i.e. Tension in the tight side of the belt.}$$

When centrifugal tension is considered, then

$$T \text{ (or } T_{t1}) = T_1 + T_C$$

### 18.22 Condition for the Transmission of Maximum Power

We know that the power transmitted by a belt,

$$P = (T_1 - T_2) v \quad \dots(i)$$

where  $T_1$  = Tension in the tight side in newtons,  
 $T_2$  = Tension in the slack side in newtons, and  
 $v$  = Velocity of the belt in m/s.

From Art. 18.19, ratio of driving tensions is

$$\frac{T_1}{T_2} = e^{\mu\theta} \text{ or } T_2 = \frac{T_1}{e^{\mu\theta}} \quad \dots(ii)$$

Substituting the value of  $T_2$  in equation (i), we have

$$P = \left( T_1 - \frac{T_1}{e^{\mu\theta}} \right) v = T_1 \left( 1 - \frac{1}{e^{\mu\theta}} \right) v = T_1 \cdot v \cdot C \quad \dots(iii)$$

where  $C = \left( 1 - \frac{1}{e^{\mu\theta}} \right)$

We know that

$$T_1 = T - T_C$$

where  $T$  = Maximum tension to which the belt can be subjected in newtons,  
 and

$$T_C = \text{Centrifugal tension in newtons.}$$

Substituting the value of  $T_1$  in equation (iii), we have

$$P = (T - T_C) v \times C$$

$$= (T - mv^2) v \times C = (T \cdot v - m \cdot v^3) C \quad \dots (\text{Substituting } T_C = m \cdot v^2)$$

## 698 ■ A Textbook of Machine Design

For maximum power, differentiate the above expression with respect to  $v$  and equate to zero, *i.e.*

$$\frac{dP}{dv} = 0 \quad \text{or} \quad \frac{d}{dv} (T.v - m.v^3) C = 0$$

or  $T - 3m.v^2 = 0$  ... (iv)

$\therefore T - 3T_C = 0$  or  $T = 3T_C$  ... ( $\because m.v^2 = T_C$ )

It shows that when the power transmitted is maximum, 1/3rd of the maximum tension is absorbed as centrifugal tension.

**Notes : 1.** We know that  $T_1 = T - T_C$  and for maximum power,  $T_C = \frac{T}{3}$ .

$$\therefore T_1 = T - \frac{T}{3} = \frac{2T}{3}$$

**2.** From equation (iv), we find that the velocity of the belt for maximum power,

$$v = \sqrt{\frac{T}{3m}}$$

**Example 18.3.** A leather belt  $9 \text{ mm} \times 250 \text{ mm}$  is used to drive a cast iron pulley  $900 \text{ mm}$  in diameter at  $336 \text{ r.p.m.}$  If the active arc on the smaller pulley is  $120^\circ$  and the stress in tight side is  $2 \text{ MPa}$ , find the power capacity of the belt. The density of leather may be taken as  $980 \text{ kg/m}^3$ , and the coefficient of friction of leather on cast iron is  $0.35$ .

**Solution.** Given:  $t = 9 \text{ mm} = 0.009 \text{ m}$ ;  $b = 250 \text{ mm} = 0.25 \text{ m}$ ;  $d = 900 \text{ mm} = 0.9 \text{ m}$ ;  
 $N = 336 \text{ r.p.m.}$ ;  $\theta = 120^\circ = 120 \times \frac{\pi}{180} = 2.1 \text{ rad}$ ;  $\sigma = 2 \text{ MPa} = 2 \text{ N/mm}^2$ ;  $\rho = 980 \text{ kg/m}^3$ ;  $\mu = 0.35$

We know that the velocity of the belt,

$$v = \frac{\pi d.N}{60} = \frac{\pi \times 0.9 \times 336}{60} = 15.8 \text{ m/s}$$

and cross-sectional area of the belt,

$$a = b.t = 9 \times 250 = 2250 \text{ mm}^2$$

$\therefore$  Maximum or total tension in the tight side of the belt,

$$T = T_{t1} = \sigma.a = 2 \times 2250 = 4500 \text{ N}$$

We know that mass of the belt per metre length,

$$m = \text{Area} \times \text{length} \times \text{density} = b.t.l.\rho = 0.25 \times 0.009 \times 1 \times 980 \text{ kg/m} \\ = 2.2 \text{ kg/m}$$

$\therefore$  Centrifugal tension,

$$*T_C = m.v^2 = 2.2 (15.8)^2 = 550 \text{ N}$$

and tension in the tight side of the belt,

$$T_1 = T - T_C = 4500 - 550 = 3950 \text{ N}$$

Let

$$T_2 = \text{Tension in the slack side of the belt.}$$

We know that

$$2.3 \log \left( \frac{T_1}{T_2} \right) = \mu.\theta = 0.35 \times 2.1 = 0.735$$

$$\log \left( \frac{T_1}{T_2} \right) = \frac{0.735}{2.3} = 0.3196 \quad \text{or} \quad \frac{T_1}{T_2} = 2.085 \quad \dots \text{ (Taking antilog of 0.3196)}$$

\*  $T_C = m.v^2 = \frac{\text{kg}}{\text{m}} \times \frac{\text{m}^2}{\text{s}^2} = \text{kg-m/s}^2$  or N ... ( $\because 1 \text{ N} = 1 \text{ kg-m/s}^2$ )

and 
$$T_2 = \frac{T_1}{2.085} = \frac{3950}{2.085} = 1895 \text{ N}$$

We know that the power capacity of the belt,

$$P = (T_1 - T_2) v = (3950 - 1895) 15.8 = 32\,470 \text{ W} = 32.47 \text{ kW Ans.}$$

**Notes :** The power capacity of the belt, when centrifugal tension is taken into account, may also be obtained as discussed below :

1. We know that the maximum tension in the tight side of the belt,

$$T_{t1} = T = 4500 \text{ N}$$

Centrifugal tension,  $T_C = 550 \text{ N}$

and tension in the slack side of the belt,

$$T_2 = 1895 \text{ N}$$

∴ Total tension in the slack side of the belt,

$$T_{t2} = T_2 + T_C = 1895 + 550 = 2445 \text{ N}$$

We know that the power capacity of the belt,

$$P = (T_{t1} - T_{t2}) v = (4500 - 2445) 15.8 = 32\,470 \text{ W} = 32.47 \text{ kW Ans.}$$

2. The value of total tension in the slack side of the belt ( $T_{t2}$ ) may also be obtained by using the relation as discussed in Art. 18.20, i.e.

$$2.3 \log \left( \frac{T_{t1} - T_C}{T_{t2} - T_C} \right) = \mu \cdot \theta$$

**Example 18.4.** A flat belt is required to transmit 30 kW from a pulley of 1.5 m effective diameter running at 300 r.p.m. The angle of contact is spread over  $\frac{11}{24}$  of the circumference. The coefficient of friction between the belt and pulley surface is 0.3. Determine, taking centrifugal tension into account, width of the belt required. It is given that the belt thickness is 9.5 mm, density of its material is 1100 kg/m<sup>3</sup> and the related permissible working stress is 2.5 MPa.

**Solution.** Given :  $P = 30 \text{ kW} = 30 \times 10^3 \text{ W}$  ;  $d = 1.5 \text{ m}$  ;  $N = 300 \text{ r.p.m.}$  ;  $\theta = \frac{11}{24} \times 360 = 165^\circ$   
 $= 165 \times \pi / 180 = 2.88 \text{ rad}$  ;  $\mu = 0.3$  ;  $t = 9.5 \text{ mm} = 0.0095 \text{ m}$  ;  $\rho = 1100 \text{ kg/m}^3$  ;  $\sigma = 2.5 \text{ MPa}$   
 $= 2.5 \times 10^6 \text{ N/m}^2$

Let  $T_1 =$  Tension in the tight side of the belt in newtons, and  
 $T_2 =$  Tension in the slack side of the belt in newtons.

We know that the velocity of the belt,

$$v = \frac{\pi d N}{60} = \frac{\pi \times 1.5 \times 300}{60} = 23.57 \text{ m/s}$$

and power transmitted ( $P$ ),

$$30 \times 10^3 = (T_1 - T_2) v = (T_1 - T_2) 23.57$$

$$\therefore T_1 - T_2 = 30 \times 10^3 / 23.57 = 1273 \text{ N} \quad \dots(i)$$

We know that

$$2.3 \log \left( \frac{T_1}{T_2} \right) = \mu \cdot \theta = 0.3 \times 2.88 = 0.864$$

$$\therefore \log \left( \frac{T_1}{T_2} \right) = \frac{0.864}{2.3} = 0.3756 \quad \text{or} \quad \frac{T_1}{T_2} = 2.375 \quad \dots(ii)$$

... (Taking antilog of 0.3756)

From equations (i) and (ii), we find that

$$T_1 = 2199 \text{ N} ; \text{ and } T_2 = 926 \text{ N}$$

## 700 ■ A Textbook of Machine Design

Let  $b$  = Width of the belt required in metres.

We know that mass of the belt per metre length,

$$m = \text{Area} \times \text{length} \times \text{density} = b \times t \times l \times \rho$$

$$= b \times 0.0095 \times 1 \times 1100 = 10.45 b \text{ kg/m}$$

and centrifugal tension,  $T_C = m.v^2 = 10.45 b (23.57)^2 = 5805 b \text{ N}$

We know that maximum tension in the belt,

$$T = T_1 + T_C = \text{Stress} \times \text{Area} = \sigma.b.t$$

or  $2199 + 5805 b = 2.5 \times 10^6 \times b \times 0.0095 = 23\,750 b$

$$\therefore 23\,750 b - 5805 b = 2199 \text{ or } b = 0.122 \text{ m or } 122 \text{ mm}$$

The standard width of the belt is 125 mm. **Ans.**

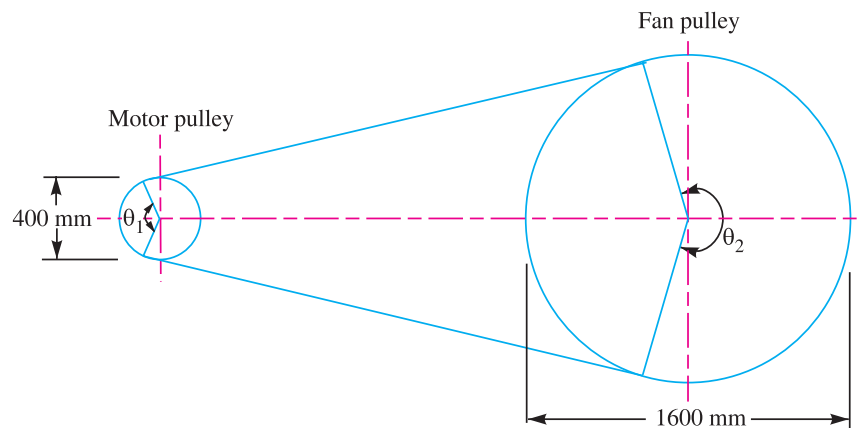
**Example 18.5.** An electric motor drives an exhaust fan. Following data are provided :

	Motor pulley	Fan pulley
Diameter	400 mm	1600 mm
Angle of wrap	2.5 radians	3.78 radians
Coefficient of friction	0.3	0.25
Speed	700 r.p.m.	—
Power transmitted	22.5 kW	—

Calculate the width of 5 mm thick flat belt. Take permissible stress for the belt material as 2.3 MPa.

**Solution.** Given :  $d_1 = 400 \text{ mm}$  or  $r_1 = 200 \text{ mm}$  ;  $d_2 = 1600 \text{ mm}$  or  $r_2 = 800 \text{ mm}$  ;  $\theta_1 = 2.5 \text{ rad}$  ;  $\theta_2 = 3.78 \text{ rad}$  ;  $\mu_1 = 0.3$  ;  $\mu_2 = 0.25$  ;  $N_1 = 700 \text{ r.p.m.}$  ;  $P = 22.5 \text{ kW} = 22.5 \times 10^3 \text{ W}$  ;  $t = 5 \text{ mm} = 0.005 \text{ m}$  ;  $\sigma = 2.3 \text{ MPa} = 2.3 \times 10^6 \text{ N/m}^2$

Fig. 18.19 shows a system of flat belt drive. Suffix 1 refers to motor pulley and suffix 2 refers to fan pulley.



**Fig. 18.19**

We have discussed in Art. 18.19 (Note 2) that when the pulleys are made of different material [*i.e.* when the pulleys have different coefficient of friction ( $\mu$ ) or different angle of contact ( $\theta$ )], then the design will refer to a pulley for which  $\mu.\theta$  is small.

$$\therefore \text{For motor pulley, } \mu_1.\theta_1 = 0.3 \times 2.5 = 0.75$$

$$\text{and for fan pulley, } \mu_2.\theta_2 = 0.25 \times 3.78 = 0.945$$



Since  $\mu_1 \cdot \theta_1$  for the motor pulley is small, therefore the design is based on the motor pulley.

Let  $T_1$  = Tension in the tight side of the belt, and  
 $T_2$  = Tension in the slack side of the belt.

We know that the velocity of the belt,

$$v = \frac{\pi d_1 N_1}{60} = \frac{\pi \times 0.4 \times 700}{60} = 14.7 \text{ m/s} \quad \dots (d_1 \text{ is taken in metres})$$

and the power transmitted ( $P$ ),

$$22.5 \times 10^3 = (T_1 - T_2) v = (T_1 - T_2) 14.7$$

$$\therefore T_1 - T_2 = 22.5 \times 10^3 / 14.7 = 1530 \text{ N} \quad \dots (i)$$

We know that

$$2.3 \log \left( \frac{T_1}{T_2} \right) = \mu_1 \cdot \theta_1 = 0.3 \times 2.5 = 0.75$$

$$\therefore \log \left( \frac{T_1}{T_2} \right) = \frac{0.75}{2.3} = 0.3261 \quad \text{or} \quad \frac{T_1}{T_2} = 2.12 \quad \dots (ii)$$

... (Taking antilog of 0.3261)

From equations (i) and (ii), we find that

$$T_1 = 2896 \text{ N}; \text{ and } T_2 = 1366 \text{ N}$$

Let  $b$  = Width of the belt in metres.

Since the velocity of the belt is more than 10 m/s, therefore centrifugal tension must be taken into consideration. Assuming a leather belt for which the density may be taken as 1000 kg / m<sup>3</sup>.

$\therefore$  Mass of the belt per metre length,

$$m = \text{Area} \times \text{length} \times \text{density} = b \times t \times l \times \rho$$

$$= b \times 0.005 \times 1 \times 1000 = 5 b \text{ kg/m}$$

and centrifugal tension,  $T_C = m \cdot v^2 = 5 b (14.7)^2 = 1080 b \text{ N}$

We know that the maximum (or total) tension in the belt,

$$T = T_1 + T_C = \text{Stress} \times \text{Area} = \sigma \cdot b \cdot t$$

or  $2896 + 1080 b = 2.3 \times 10^6 b \times 0.005 = 11\,500 b$

$$\therefore 11\,500 b - 1080 b = 2896 \quad \text{or} \quad b = 0.278 \text{ say } 0.28 \text{ m or } 280 \text{ mm Ans.}$$

**Example 18.6.** Design a rubber belt to drive a dynamo generating 20 kW at 2250 r.p.m. and fitted with a pulley 200 mm diameter. Assume dynamo efficiency to be 85%.

Allowable stress for belt = 2.1 MPa

Density of rubber = 1000 kg / m<sup>3</sup>

Angle of contact for dynamo pulley = 165°

Coefficient of friction between belt and pulley = 0.3

**Solution.** Given :  $P = 20 \text{ kW} = 20 \times 10^3 \text{ W}$ ;  $N = 2250 \text{ r.p.m.}$ ;  $d = 200 \text{ mm} = 0.2 \text{ m}$ ;  
 $\eta_d = 85\% = 0.85$ ;  $\sigma = 2.1 \text{ MPa} = 2.1 \times 10^6 \text{ N/m}^2$ ;  $\rho = 1000 \text{ kg/m}^3$ ;  $\theta = 165^\circ = 165 \times \pi/180 = 2.88 \text{ rad}$ ;  $\mu = 0.3$

Let  $T_1$  = Tension in the tight side of the belt, and  
 $T_2$  = Tension in the slack side of the belt.

We know that velocity of the belt,

$$v = \frac{\pi d \cdot N}{60} = \frac{\pi \times 0.2 \times 2250}{60} = 23.6 \text{ m/s}$$

## 702 ■ A Textbook of Machine Design

and power transmitted ( $P$ ),

$$\begin{aligned} 20 \times 10^3 &= (T_1 - T_2) v \eta_d \\ &= (T_1 - T_2) 23.6 \times 0.85 \\ &= 20.1 (T_1 - T_2) \end{aligned}$$

$$\therefore T_1 - T_2 = 20 \times 10^3 / 20.1 = 995 \text{ N} \dots (i)$$

We know that

$$2.3 \log \left( \frac{T_1}{T_2} \right) = \mu \cdot \theta = 0.3 \times 2.88 = 0.864$$

$$\therefore \log \left( \frac{T_1}{T_2} \right) = \frac{0.864}{2.3} = 0.3756$$

$$\text{or } \frac{T_1}{T_2} = 2.375 \dots (ii)$$

... (Taking antilog of 0.3756)

From equations (i) and (ii), we find that

$$T_1 = 1719 \text{ N}; \text{ and } T_2 = 724 \text{ N}$$

Let  $b$  = Width of the belt in metres, and

$t$  = Thickness of the belt in metres.

Assuming thickness of the belt,  $t = 10 \text{ mm} = 0.01 \text{ m}$ , we have

Cross-sectional area of the belt

$$= b \times t = b \times 0.01 = 0.01 b \text{ m}^2$$

We know that mass of the belt per metre length,

$$m = \text{Area} \times \text{length} \times \text{density} = 0.01 b \times 1 \times 1000 = 10 b \text{ kg / m}$$

$\therefore$  Centrifugal tension,

$$T_C = m \cdot v^2 = 10 b (23.6)^2 = 5570 b \text{ N}$$

We know that maximum tension in the belt,

$$T = \sigma \cdot b \cdot t = 2.1 \times 10^6 \times b \times 0.01 = 21\,000 b \text{ N}$$

and tension in the tight side of belt ( $T_1$ ),

$$1719 = T - T_C = 21\,000 b - 5570 b = 15\,430 b$$

$$\therefore b = 1719 / 15\,430 = 0.1114 \text{ m} = 111.4 \text{ mm}$$

The standard width of the belt ( $b$ ) is 112 mm. **Ans.**

**Example 18.7.** Design a belt drive to transmit 110 kW for a system consisting of two pulleys of diameters 0.9 m and 1.2 m, centre distance of 3.6 m, a belt speed 20 m / s, coefficient of friction 0.3, a slip of 1.2% at each pulley and 5% friction loss at each shaft, 20% over load.

**Solution.** Given :  $P = 110 \text{ kW} = 110 \times 10^3 \text{ W}$ ;  $d_1 = 0.9 \text{ m}$  or  $r_1 = 0.45 \text{ m}$ ;  $d_2 = 1.2 \text{ m}$  or  $r_2 = 0.6 \text{ m}$ ;  $x = 3.6 \text{ m}$ ;  $v = 20 \text{ m/s}$ ;  $\mu = 0.3$ ;  $s_1 = s_2 = 1.2\%$

Fig 18.20 shows a system of flat belt drive consisting of two pulleys.

Let  $N_1$  = Speed of the smaller or driving pulley in r.p.m., and

and  $N_2$  = Speed of the larger or driven pulley in r.p.m.

We know that speed of the belt ( $v$ ),

$$20 = \frac{\pi d_1 N_1}{60} \left( 1 - \frac{s_1}{100} \right) = \frac{\pi \times 0.9 N_1}{60} \left( 1 - \frac{1.2}{100} \right) = 0.0466 N_1$$

$$\therefore N_1 = 20 / 0.0466 = 430 \text{ r.p.m.}$$



Rubber belt

and peripheral velocity of the driven pulley,

$$\frac{\pi d_2 \cdot N_2}{60} = \text{Belt speed in m/s} \left(1 - \frac{s_2}{100}\right) = v \left(1 - \frac{s_2}{100}\right)$$

or

$$\frac{\pi \times 1.2 \times N_2}{60} = 20 \left(1 - \frac{1.2}{100}\right) = 19.76$$

∴

$$N_2 = \frac{19.76 \times 60}{\pi \times 1.2} = 315 \text{ r.p.m.}$$

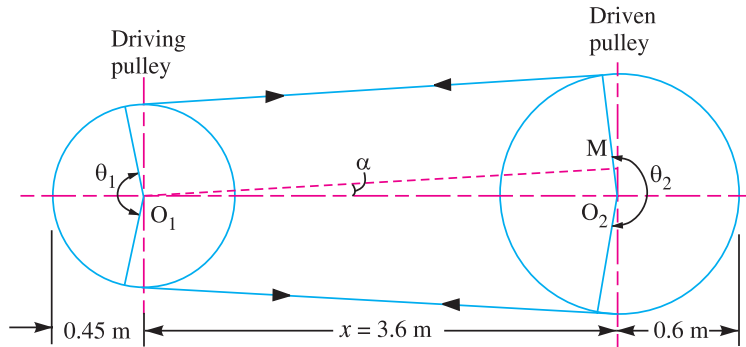


Fig. 18.20

We know that the torque acting on the driven shaft

$$= \frac{\text{Power transmitted} \times 60}{2 \pi N_2} = \frac{110 \times 10^3 \times 60}{2 \pi \times 315} = 3334 \text{ N-m}$$

Since there is a 5% friction loss at each shaft, therefore torque acting on the belt

$$= 1.05 \times 3334 = 3500 \text{ N-m}$$

Since the belt is to be designed for 20% overload, therefore design torque

$$= 1.2 \times 3500 = 4200 \text{ N-m}$$

Let

$T_1$  = Tension in the tight side of the belt, and

$T_2$  = Tension in the slack side of the belt.

We know that the torque exerted on the driven pulley

$$= (T_1 - T_2) r_2 = (T_1 - T_2) 0.6 = 0.6 (T_1 - T_2) \text{ N-m}$$

Equating this to the design torque, we have

$$0.6 (T_1 - T_2) = 4200 \text{ or } T_1 - T_2 = 4200 / 0.6 = 7000 \text{ N} \quad \dots(i)$$

Now let us find out the angle of contact ( $\theta_1$ ) of the belt on the smaller or driving pulley.

From the geometry of the Fig. 18.20, we find that

$$\sin \alpha = \frac{O_2 M}{O_1 O_2} = \frac{r_2 - r_1}{x} = \frac{0.6 - 0.45}{3.6} = 0.0417 \text{ or } \alpha = 2.4^\circ$$

$$\therefore \theta_1 = 180^\circ - 2\alpha = 180 - 2 \times 2.4 = 175.2^\circ = 175.2 \times \frac{\pi}{180} = 3.06 \text{ rad}$$

We know that

$$2.3 \log \left(\frac{T_1}{T_2}\right) = \mu \cdot \theta_1 = 0.3 \times 3.06 = 0.918$$

$$\therefore \log \left(\frac{T_1}{T_2}\right) = \frac{0.918}{2.3} = 0.3991 \text{ or } \frac{T_1}{T_2} = 2.51 \dots \text{(Taking antilog of 0.3991)} \dots(ii)$$

## 704 ■ A Textbook of Machine Design

From equations (i) and (ii), we find that

$$T_1 = 11\,636 \text{ N}; \text{ and } T_2 = 4636 \text{ N}$$

Let  $\sigma$  = Safe stress for the belt =  $2.5 \text{ MPa} = 2.5 \times 10^6 \text{ N/m}^2$  ... (Assume)

$t$  = Thickness of the belt =  $15 \text{ mm} = 0.015 \text{ m}$ , and ... (Assume)

$b$  = Width of the belt in metres.

Since the belt speed is more than  $10 \text{ m/s}$ , therefore centrifugal tension must be taken into consideration. Assuming a leather belt for which the density may be taken as  $1000 \text{ kg/m}^3$ .

$\therefore$  Mass of the belt per metre length,

$$\begin{aligned} m &= \text{Area} \times \text{length} \times \text{density} = b \times t \times l \times \rho \\ &= b \times 0.015 \times 1 \times 1000 = 15 b \text{ kg/m} \end{aligned}$$

and centrifugal tension,

$$T_C = m.v^2 = 15 b (20)^2 = 6000 b \text{ N}$$

We know that maximum tension in the belt,

$$T = T_1 + T_C = \sigma.b.t$$

or  $11\,636 + 6000 b = 2.5 \times 10^6 \times b \times 0.015 = 37\,500 b$

$\therefore 37\,500 b - 6000 b = 11\,636$  or  $b = 0.37 \text{ m}$  or  $370 \text{ mm}$

The standard width of the belt ( $b$ ) is  $400 \text{ mm}$ . **Ans.**

We know that length of the belt,

$$\begin{aligned} L &= \pi (r_2 + r_1) + 2x + \frac{(r_2 - r_1)^2}{x} \\ &= \pi (0.6 + 0.45) + 2 \times 3.6 + \frac{(0.6 - 0.45)^2}{3.6} \\ &= 3.3 + 7.2 + 0.006 = 10.506 \text{ m} \text{ **Ans.**} \end{aligned}$$

**Example 18.8.** A belt  $100 \text{ mm}$  wide and  $10 \text{ mm}$  thick is transmitting power at  $1000 \text{ metres/min}$ . The net driving tension is  $1.8$  times the tension on the slack side. If the safe permissible stress on the belt section is  $1.6 \text{ MPa}$ , calculate the maximum power, that can be transmitted at this speed. Assume density of the leather as  $1000 \text{ kg/m}^3$ .

Calculate the absolute maximum power that can be transmitted by this belt and the speed at which this can be transmitted.

**Solution.** Given :  $b = 100 \text{ mm} = 0.1 \text{ m}$  ;  $t = 10 \text{ mm} = 0.01 \text{ m}$  ;  $v = 1000 \text{ m/min} = 16.67 \text{ m/s}$  ;  $T_1 - T_2 = 1.8 T_2$  ;  $\sigma = 1.6 \text{ MPa} = 1.6 \text{ N/mm}^2$  ;  $\rho = 1000 \text{ kg/m}^3$

**Power transmitted**

Let  $T_1$  = Tension in the tight side of the belt, and

$T_2$  = Tension in the slack side of the belt.

We know that the maximum tension in the belt,

$$T = \sigma.b.t = 1.6 \times 100 \times 10 = 1600 \text{ N}$$

Mass of the belt per metre length,

$$\begin{aligned} m &= \text{Area} \times \text{length} \times \text{density} = b \times t \times l \times \rho \\ &= 0.1 \times 0.01 \times 1 \times 1000 = 1 \text{ kg/m} \end{aligned}$$

$\therefore$  Centrifugal tension,

$$T_C = m.v^2 = 1 (16.67)^2 = 278 \text{ N}$$

We know that

$$T_1 = T - T_C = 1600 - 278 = 1322 \text{ N}$$

and  $T_1 - T_2 = 1.8 T_2$  ... (Given)

∴  $T_2 = \frac{T_1}{2.8} = \frac{1322}{2.8} = 472 \text{ N}$

We know that the power transmitted,

$$P = (T_1 - T_2) v = (1322 - 472) 16.67 = 14\,170 \text{ W} = 14.17 \text{ kW Ans.}$$

**Speed at which absolute maximum power can be transmitted**

We know that the speed of the belt for maximum power,

$$v = \sqrt{\frac{T}{3m}} = \sqrt{\frac{1600}{3 \times 1}} = 23.1 \text{ m/s Ans.}$$

**Absolute maximum power**

We know that for absolute maximum power, the centrifugal tension,

$$T_C = T / 3 = 1600 / 3 = 533 \text{ N}$$

∴ Tension in the tight side,

$$T_1 = T - T_C = 1600 - 533 = 1067 \text{ N}$$

and tension in the slack side,

$$T_2 = \frac{T_1}{2.8} = \frac{1067}{2.8} = 381 \text{ N}$$

∴ Absolute maximum power transmitted,

$$P = (T_1 - T_2) v = (1067 - 381) 23.1 = 15\,850 \text{ W} = 15.85 \text{ kW Ans.}$$

**18.23 Initial Tension in the Belt**

When a belt is wound round the two pulleys (*i.e.* driver and follower), its two ends are joined together, so that the belt may continuously move over the pulleys, since the motion of the belt (from the driver) and the follower (from the belt) is governed by a firm grip due to friction between the belt and the pulleys. In order to increase this grip, the belt is tightened up. At this stage, even when the pulleys are stationary, the belt is subjected to some tension, called **initial tension**.

When the driver starts rotating, it pulls the belt from one side (increasing tension in the belt on this side) and delivers to the other side (decreasing tension in the belt on that side). The increased tension in one side of the belt is called tension in tight side and the decreased tension in the other side of the belt is called tension in the slack side.

- Let  $T_0$  = Initial tension in the belt,
- $T_1$  = Tension in the tight side of the belt,
- $T_2$  = Tension in the slack side of the belt, and
- $\alpha$  = Coefficient of increase of the belt length per unit force.

A little consideration will show that the increase of tension in the tight side

$$= T_1 - T_0$$

and increase in the length of the belt on the tight side

$$= \alpha (T_1 - T_0) \quad \dots(i)$$

Similarly, decrease in tension in the slack side

$$= T_0 - T_2$$

and decrease in the length of the belt on the slack side

$$= \alpha (T_0 - T_2) \quad \dots(ii)$$

Assuming that the belt material is perfectly elastic such that the length of the belt remains constant, when it is at rest or in motion, therefore increase in length on the tight side is equal to decrease in the length on the slack side. Thus, equating equations (i) and (ii), we have

$$\alpha (T_1 - T_0) = \alpha (T_0 - T_2)$$

## 706 ■ A Textbook of Machine Design

or

$$T_1 - T_0 = T_0 - T_2$$

$$\therefore T_0 = \frac{T_1 + T_2}{2} \quad \dots \text{(Neglecting centrifugal tension)}$$

$$= \frac{T_1 + T_2 + 2T_C}{2} \quad \dots \text{(Considering centrifugal tension)}$$

**Note:** In actual practice, the belt material is not perfectly elastic. Therefore, the sum of the tensions  $T_1$  and  $T_2$ , when the belt is transmitting power, is always greater than twice the initial tension. According to C.G. Barth, the relation between  $T_0$ ,  $T_1$  and  $T_2$  is given by

$$\sqrt{T_1} + \sqrt{T_2} = 2\sqrt{T_0}$$

**Example 18.9.** Two parallel shafts whose centre lines are 4.8 m apart, are connected by an open belt drive. The diameter of the larger pulley is 1.5 m and that of smaller pulley 1 m. The initial tension in the belt when stationary is 3 kN. The mass of the belt is 1.5 kg / m length. The coefficient of friction between the belt and the pulley is 0.3. Taking centrifugal tension into account, calculate the power transmitted, when the smaller pulley rotates at 400 r.p.m.

**Solution.** Given :  $x = 4.8$  m ;  $d_1 = 1.5$  m ;  $d_2 = 1$  m ;  $T_0 = 3$  kN = 3000 N ;  $m = 1.5$  kg/m ;  $\mu = 0.3$  ;  $N_2 = 400$  r.p.m.

We know that the velocity of the belt,

$$v = \frac{\pi d_2 N_2}{60} = \frac{\pi \times 1 \times 400}{60} = 21 \text{ m/s}$$

$\therefore$  Centrifugal tension,

$$T_C = m.v^2 = 1.5 (21)^2 = 661.5 \text{ N}$$

Let

$T_1$  = Tension in the tight side of the belt, and

$T_2$  = Tension in the slack side of the belt.

We know that the initial tension ( $T_0$ ),

$$3000 = \frac{T_1 + T_2 + 2T_C}{2} = \frac{T_1 + T_2 + 2 \times 661.5}{2}$$

$$\therefore T_1 + T_2 = 3000 \times 2 - 2 \times 661.5 = 4677 \text{ N} \quad \dots (i)$$

For an open belt drive,

$$\sin \alpha = \frac{r_1 - r_2}{x} = \frac{d_1 - d_2}{2x} = \frac{1.5 - 1}{2 \times 4.8} = 0.0521 \text{ or } \alpha = 3^\circ$$

$\therefore$  Angle of lap on the smaller pulley,

$$\theta = 180^\circ - 2\alpha = 180 - 2 \times 3 = 174^\circ$$

$$= 174 \times \frac{\pi}{180} = 3.04 \text{ rad}$$

We know that

$$2.3 \log \left( \frac{T_1}{T_2} \right) = \mu \cdot \theta = 0.3 \times 3.04 = 0.912$$

$$\log \left( \frac{T_1}{T_2} \right) = \frac{0.912}{2.3} = 0.3965 \text{ or } \frac{T_1}{T_2} = 2.5 \quad \dots \text{(Taking antilog of 0.3965) } \dots (ii)$$

From equations (i) and (ii), we have

$$T_1 = 3341 \text{ N ; and } T_2 = 1336 \text{ N}$$

We know that the power transmitted,

$$P = (T_1 - T_2) v = (3341 - 1336) 21 = 42\,100 \text{ W} = 42.1 \text{ kW Ans.}$$

**Example 18.10.** In a horizontal belt drive for a centrifugal blower, the blower is belt driven at 600 r.p.m. by a 15 kW, 1750 r.p.m. electric motor. The centre distance is twice the diameter of the larger pulley. The density of the belt material = 1500 kg/m<sup>3</sup>; maximum allowable stress = 4 MPa;  $\mu_1 = 0.5$  (motor pulley);  $\mu_2 = 0.4$  (blower pulley); peripheral velocity of the belt = 20 m/s. Determine the following:

1. Pulley diameters; 2. belt length; 3. cross-sectional area of the belt; 4. minimum initial tension for operation without slip; and 5. resultant force in the plane of the blower when operating with an initial tension 50 per cent greater than the minimum value.

**Solution.** Given :  $N_2 = 600$  r.p.m. ;  $P = 15$  kW =  $15 \times 10^3$  W ;  $N_1 = 1750$  r.p.m. ;  $\rho = 1500$  kg/m<sup>3</sup> ;  $\sigma = 4$  MPa =  $4 \times 10^6$  N/m<sup>2</sup> ;  $\mu_1 = 0.5$  ;  $\mu_2 = 0.4$  ;  $v = 20$  m/s

Fig. 18.21 shows a horizontal belt drive. Suffix 1 refers to a motor pulley and suffix 2 refers to a blower pulley.

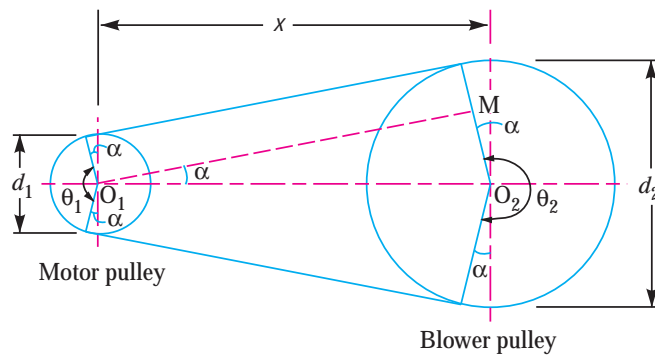


Fig. 18.21

**1. Pulley diameters**

Let  $d_1$  = Diameter of the motor pulley, and  
 $d_2$  = Diameter of the blower pulley.

We know that peripheral velocity of the belt ( $v$ ),

$$20 = \frac{\pi d_1 N_1}{60} = \frac{\pi d_1 \times 1750}{60} = 91.64 d_1$$

$\therefore d_1 = 20 / 91.64 = 0.218 \text{ m} = 218 \text{ mm Ans.}$

We also know that  $\frac{N_2}{N_1} = \frac{d_1}{d_2}$

$\therefore d_2 = \frac{d_1 \times N_1}{N_2} = \frac{218 \times 1750}{600} = 636 \text{ mm Ans.}$

**2. Belt length**

Since the centre distance ( $x$ ) between the two pulleys is twice the diameter of the larger pulley (i.e.  $2 d_2$ ), therefore centre distance,

$$x = 2 d_2 = 2 \times 636 = 1272 \text{ mm}$$

We know that length of belt,

$$\begin{aligned} L &= \frac{\pi}{2} (d_1 + d_2) + 2 x + \frac{(d_1 - d_2)^2}{4x} \\ &= \frac{\pi}{2} (218 + 636) + 2 \times 1272 + \frac{(218 - 636)^2}{4 \times 1272} \\ &= 1342 + 2544 + 34 = 3920 \text{ mm} = 3.92 \text{ m Ans.} \end{aligned}$$

3. Cross-sectional area of the belt

Let  $a$  = Cross-sectional area of the belt.

First of all, let us find the angle of contact for both the pulleys. From the geometry of the figure, we find that

$$\sin \alpha = \frac{O_2 M}{O_1 O_2} = \frac{r_2 - r_1}{x} = \frac{d_2 - d_1}{2x} = \frac{636 - 218}{2 \times 1272} = 0.1643$$

$$\therefore \alpha = 9.46^\circ$$

We know that angle of contact on the motor pulley,

$$\begin{aligned} \theta_1 &= 180^\circ - 2\alpha = 180 - 2 \times 9.46 = 161.08^\circ \\ &= 161.08 \times \pi / 180 = 2.8 \text{ rad} \end{aligned}$$

and angle of contact on the blower pulley,

$$\begin{aligned} \theta_2 &= 180^\circ + 2\alpha = 180 + 2 \times 9.46 = 198.92^\circ \\ &= 198.92 \times \pi / 180 = 3.47 \text{ rad} \end{aligned}$$

Since both the pulleys have different coefficient of friction ( $\mu$ ), therefore the design will refer to a pulley for which  $\mu \cdot \theta$  is small.

$\therefore$  For motor pulley,

$$\mu_1 \cdot \theta_1 = 0.5 \times 2.8 = 1.4$$

and for blower pulley,  $\mu_2 \cdot \theta_2 = 0.4 \times 3.47 = 1.388$

Since  $\mu_2 \cdot \theta_2$  for the blower pulley is less than  $\mu_1 \cdot \theta_1$ , therefore the design is based on the blower pulley.

Let  $T_1$  = Tension in the tight side of the belt, and  
 $T_2$  = Tension in the slack side of the belt.

We know that power transmitted ( $P$ ),

$$15 \times 10^3 = (T_1 - T_2) v = (T_1 - T_2) 20$$

$$\therefore T_1 - T_2 = 15 \times 10^3 / 20 = 750 \text{ N} \quad \dots(i)$$

We also know that

$$2.3 \log \left( \frac{T_1}{T_2} \right) = \mu_2 \cdot \theta_2 = 0.4 \times 3.47 = 1.388$$

$$\therefore \log \left( \frac{T_1}{T_2} \right) = \frac{1.388}{2.3} = 0.6035 \quad \text{or} \quad \frac{T_1}{T_2} = 4 \quad \dots(ii)$$

... (Taking antilog of 0.6035)

From equations (i) and (ii),

$$T_1 = 1000 \text{ N ; and } T_2 = 250 \text{ N}$$

Mass of the belt per metre length,

$$\begin{aligned} m &= \text{Area} \times \text{length} \times \text{density} = a \times l \times \rho \\ &= a \times 1 \times 1500 = 1500 a \text{ kg / m} \end{aligned}$$

$\therefore$  Centrifugal tension,

$$T_C = m \cdot v^2 = 1500 a (20)^2 = 0.6 \times 10^6 a \text{ N}$$

We know that maximum or total tension in the belt,

$$T = T_1 + T_C = 1000 + 0.6 \times 10^6 a \text{ N} \quad \dots(iii)$$

We also know that maximum tension in the belt,

$$T = \text{Stress} \times \text{area} = \sigma \times a = 4 \times 10^6 a \text{ N} \quad \dots(iv)$$



From equations (iii) and (iv),

$$1000 + 0.6 \times 10^6 a = 4 \times 10^6 a \quad \text{or} \quad 3.4 \times 10^6 a = 1000$$

$$\therefore a = 1000 / 3.4 \times 10^6 = 294 \times 10^{-6} \text{ m}^2 = 294 \text{ mm}^2 \text{ Ans.}$$

**4. Minimum initial tension for operation without slip**

We know that centrifugal tension,

$$T_C = 0.6 \times 10^6 a = 0.6 \times 10^6 \times 294 \times 10^{-6} = 176.4 \text{ N}$$

∴ Minimum initial tension for operation without slip,

$$T_0 = \frac{T_1 + T_2 + 2T_C}{2} = \frac{1000 + 250 + 2 \times 176.4}{2} = 801.4 \text{ N Ans.}$$

**5. Resultant force in the plane of the blower when operating with an initial tension 50 per cent greater than the minimum value**

We have calculated above that the minimum initial tension,

$$T_0 = 801.4 \text{ N}$$

∴ Increased initial tension,

$$T_0' = 801.4 + 801.4 \times \frac{50}{100} = 1202 \text{ N}$$

Let  $T_1'$  and  $T_2'$  be the corresponding tensions in the tight side and slack side of the belt respectively.

We know that increased initial tension ( $T_0'$ ),

$$1202 = \frac{T_1' + T_2' + 2T_C}{2} = \frac{T_1' + T_2' + 2 \times 176.4}{2}$$

$$\therefore T_1' + T_2' = 1202 \times 2 - 2 \times 176.4 = 2051.2 \text{ N} \quad \dots(v)$$

Since the ratio of tensions will be constant, i.e.  $\frac{T_1'}{T_2'} = \frac{T_1}{T_2} = 4$ , therefore from equation (v), we have

$$4T_2' + T_2' = 2051.2 \quad \text{or} \quad T_2' = 2051.2 / 5 = 410.24 \text{ N}$$

and

$$T_1' = 4 T_2' = 4 \times 410.24 = 1640.96 \text{ N}$$

∴ Resultant force in the plane of the blower

$$= T_1' - T_2' = 1640.96 - 410.24 = 1230.72 \text{ N Ans.}$$

**Example 18.11.** An open belt connects two flat pulleys. The pulley diameters are 300 mm and 450 mm and the corresponding angles of lap are  $160^\circ$  and  $210^\circ$ . The smaller pulley runs at 200 r.p.m. The coefficient of friction between the belt and pulley is 0.25. It is found that the belt is on the point of slipping when 3 kW is transmitted. To increase the power transmitted two alternatives are suggested, namely (i) increasing the initial tension by 10%, and (ii) increasing the coefficient of friction by 10% by the application of a suitable dressing to the belt.

Which of these two methods would be more effective? Find the percentage increase in power possible in each case.

**Solution.** Given :  $d_1 = 300 \text{ mm} = 0.3 \text{ m}$  ;  $d_2 = 450 \text{ mm} = 0.45 \text{ m}$  ;  $\theta_1 = 160^\circ = 160 \times \frac{\pi}{180} = 2.8 \text{ rad}$  ;  $\theta_2 = 210^\circ = 210 \times \frac{\pi}{180} = 3.66 \text{ rad}$  ;  $N_1 = 200 \text{ r.p.m.}$  ;  $\mu = 0.25$  ;  $P = 3 \text{ kW} = 3000 \text{ W}$

Let  $T_1$  = Tension in the tight side of the belt, and  
 $T_2$  = Tension in the slack side of the belt.

We have discussed in Art 18.19 (Note 2) that when the pulleys are made of different material [i.e. when the pulleys have different coefficient of friction ( $\mu$ ) or different angle of contact ( $\theta$ )], then the design will be refer to a pulley for which  $\mu.\theta$  is small.

## 710 ■ A Textbook of Machine Design

∴ For smaller pulley,  $\mu.\theta_1 = 0.25 \times 2.8 = 0.7$

and for larger pulley,  $\mu.\theta_2 = 0.25 \times 3.66 = 0.915$

Since  $\mu.\theta_1$  for the smaller pulley is less than  $\mu.\theta_2$ , therefore the design is based on the smaller pulley.

We know that velocity of the belt,

$$v = \frac{\pi d_1 N_1}{60} = \frac{\pi \times 0.3 \times 200}{60} = 3.142 \text{ m/s}$$

and power transmitted ( $P$ ),

$$3000 = (T_1 - T_2) v = (T_1 - T_2) 3.142$$

$$\therefore T_1 - T_2 = 3000 / 3.142 = 955 \text{ N} \quad \dots(i)$$

We know that

$$2.3 \log \left( \frac{T_1}{T_2} \right) = \mu.\theta_1 = 0.25 \times 2.8 = 0.7$$

$$\therefore \log \left( \frac{T_1}{T_2} \right) = \frac{0.7}{2.3} = 0.3043 \quad \text{or} \quad \frac{T_1}{T_2} = 2.015 \quad \dots(ii)$$

... (Taking antilog of 0.3043)

From equations (i) and (ii), we find that

$$T_1 = 1896 \text{ N, and } T_2 = 941 \text{ N}$$

### (i) Power transmitted when initial tension is increased by 10%

We know that the initial tension,

$$T_0 = \frac{T_1 + T_2}{2} = \frac{1896 + 941}{2} = 1418.5 \text{ N}$$

∴ Increased initial tension,

$$T_0' = 1418.5 + 1418.5 \times \frac{10}{100} = 1560.35 \text{ N}$$

Let  $T_1$  and  $T_2$  be the corresponding tensions in the tight side and slack side of the belt respectively.

$$\therefore T_0' = \frac{T_1 + T_2}{2}$$

$$\text{or} \quad T_1 + T_2 = 2 T_0' = 2 \times 1560.35 = 3120.7 \text{ N} \quad \dots(iii)$$

Since the ratio of the tensions is constant, i.e.  $T_1 / T_2 = 2.015$  or  $T_1 = 2.015 T_2$ , therefore from equation (iii),

$$2.015 T_2 + T_2 = 3120.7 \quad \text{or} \quad T_2 = 3120.7 / 3.015 = 1035 \text{ N}$$

$$\text{and} \quad T_1 = 2.015 T_2 = 2.015 \times 1035 = 2085.7 \text{ N}$$

∴ Power transmitted,

$$P = (T_1 - T_2) v = (2085.7 - 1035) 3.142 = 3300 \text{ W} = 3.3 \text{ kW}$$

### (ii) Power transmitted when the coefficient of friction is increased by 10%

We know that the coefficient of friction,

$$\mu = 0.25$$

∴ Increased coefficient of friction,

$$\mu' = 0.25 + 0.25 \times \frac{10}{100} = 0.275$$

Let  $T_1$  and  $T_2$  be the corresponding tensions in the tight side and slack side of the belt respectively. We know that

$$2.3 \log \left( \frac{T_1}{T_2} \right) = \mu' \theta_1 = 0.275 \times 2.8 = 0.77$$

$$\therefore \log \left( \frac{T_1}{T_2} \right) = \frac{0.77}{2.3} = 0.3348 \quad \text{or} \quad \frac{T_1}{T_2} = 2.16 \quad \dots(iv)$$

... (Taking antilog of 0.3348)

Here the initial tension is constant, *i.e.*

$$T_0 = \frac{T_1 + T_2}{2}$$

$$\therefore T_1 + T_2 = 2 T_0 = 2 \times 1418.5 = 2837 \text{ N} \quad \dots(v)$$

From equations (iv) and (v), we find that

$$T_1 = 1939 \text{ N, and } T_2 = 898 \text{ N}$$

∴ Power transmitted,

$$P = (T_1 - T_2) v = (1939 - 898) 3.142 = 3271 \text{ W} = 3.217 \text{ kW}$$

Since the power transmitted by increasing the initial tension is more, therefore in order to increase the power transmitted, we shall adopt the method of increasing the initial tension. **Ans.**

**Percentage increase in power**

Percentage increase in power when the initial tension is increased

$$= \frac{3.3 - 3}{3} \times 100 = 10\% \quad \text{Ans.}$$

Percentage increase in power when coefficient of friction is increased,

$$= \frac{3.271 - 3}{3} \times 100 = 9.03\% \quad \text{Ans.}$$

**EXERCISES**

1. An engine shaft running at 120 r.p.m. is required to drive a machine shaft by means of a belt. The pulley on the engine shaft is of 2 m diameter and that of the machine shaft is 1 m diameter. If the belt thickness is 5 mm; determine the speed of the machine shaft, when
  1. there is no slip; and
  2. there is a slip of 3%. [Ans. 239.4 r.p.m. ; 232.3 r.p.m.]
2. A pulley is driven by a flat belt running at a speed of 600 m/min. The coefficient of friction between the pulley and the belt is 0.3 and the angle of lap is 160°. If the maximum tension in the belt is 700 N; find the power transmitted by a belt. [Ans. 3.974 kW]
3. Find the width of the belt necessary to transmit 10 kW to a pulley 300 mm diameter, if the pulley makes 1600 r.p.m. and the coefficient of friction between the belt and the pulley is 0.22. Assume the angle of contact as 210° and the maximum tension in the belt is not to exceed 8N/mm width. [Ans. 90 mm]
4. An open belt 100 mm wide connects two pulleys mounted on parallel shafts with their centres 2.4 m apart. The diameter of the larger pulley is 450 mm and that of the smaller pulley 300 mm. The coefficient of friction between the belt and the pulley is 0.3 and the maximum stress in the belt is limited to 14 N/mm width. If the larger pulley rotates at 120 r.p.m., find the maximum power that can be transmitted. [Ans. 2.387 kW]
5. A rough rule for leather belt is that effective tension in it, shall not exceed 15 N/mm of width for a belt of 10 mm thickness. This rule is applied to determine width of belt required to transmit 37 kW, under the following conditions :  
 Angle of lap = 165°; Coefficient of friction = 0.3; Velocity of belt = 1500 m/min; Density of leather = 950 kg/m<sup>3</sup>.

## 712 ■ A Textbook of Machine Design

Find the width of belt required.

Assuming limiting friction between belt and pulley rim, find the stress in the belt.

[Ans. 140 mm ; 1.48 MPa]

6. A leather belt, 125 mm wide and 6 mm thick, transmits power from a pulley 750 mm diameter which runs at 500 r.p.m. The angle of lap is  $150^\circ$  and  $\mu = 0.3$ . If the mass of  $1 \text{ m}^3$  of leather is 1 Mg and the stress in the belt is not to exceed  $2.75 \text{ MN/m}^2$ , find the maximum power that can be transmitted.

[Ans. 18.97 kW]

7. An exhaust fan fitted with 900 mm diameter pulley is driven by a flat belt from a 30 kW, 950 r.p.m. squirrel cage motor. The pulley on the motor shaft is 250 mm in diameter and the centre distance between the fan and motor is 2.25 m. The belt is 100 mm wide with a coefficient of friction of 0.25. If the allowable stress in the belt material is not to exceed 2 MPa, determine the necessary thickness of the belt and its total length. Take centrifugal force effect into consideration for density of belt being  $950 \text{ kg/m}^3$ .

[Ans. 26 mm ; 6.35 m]

8. A cross belt arrangement has centre distance between pulleys as 1.5 m. The diameter of bigger and smaller pulleys are 'D' and 'd' respectively. The smaller pulley rotates at 1000 r.p.m. and the bigger pulley at 500 r.p.m. The flat belt is 6 mm thick and transmits 7.5 kW power at belt speed of 13 m/s approximately. The coefficient of belt friction is 0.3 and the density of belt material is  $950 \text{ kg/m}^3$ . If the permissible tensile stress for the belt material is 1.75 MPa, calculate: 1. Diameters of pulleys; 2. Length and width of belt.

[Ans. 500 mm, 250 mm ; 4.272 m, 90 mm]

9. A blower is driven by an electric motor through a belt drive. The motor runs at 450 r.p.m. For this power transmission, a flat belt of 8 mm thickness and 250 mm width is used. The diameter of the motor pulley is 350 mm and that of the blower pulley is 1350 mm. The centre distance between these pulleys is 1850 mm and an open belt configuration is adopted. The pulleys are made of cast iron. The coefficient of friction between the belt and pulley is 0.35 and the permissible stress for the belt material can be taken as  $2.5 \text{ N/mm}^2$ . The mass of the belt is 2 kg/metre length. Find the maximum power transmitted without belt slipping in any one of the pulley.

[Ans. 38 kW]

10. A 18 kW, 900 r.p.m. motor drives a centrifugal pump at 290 r.p.m. by means of a leather belt. The pulleys are of cast iron and are 1.2 metre centre distance. The pulleys of diameter less than 150 mm should not be used. The coefficient of friction between the leather belt and the cast iron pulley is 0.35, and the mass of the belt is 9 kg/m width/m length. The maximum permissible tension per mm width of the belt is 10 N. The drive is to be designed for 20% overload.

Determine the pulley diameters, the required width and length of the belt. Also find the initial tension with which the belt is to be mounted on the pulleys.

[Ans. 460 mm ; 270 mm ; 3.4 m ; 2970 N]



Blower driven by electric motor

11. A flat belt, 8 mm thick and 100 mm wide transmits power between two pulleys, running at 1600 m/min. The mass of the belt is 0.9 kg/m length. The angle of lap in the smaller pulley is  $165^\circ$  and the coefficient of friction between the belt and pulleys is 0.3. If the maximum permissible stress in the belt is  $2 \text{ MN/m}^2$ , find (i) Maximum power transmitted, and (ii) Initial tension in the belt.

[Ans. 14.821 kW; 1.322 kN]

12. Design a flat belt drive to transmit 110 kW at a belt speed of 25 m/s between two pulleys of diameters 250 mm and 400 mm having a pulley centre distance of 1 metre. The allowable belt stress is 8.5 MPa and the belts are available having a thickness to width ratio of 0.1 and a material density of  $1100 \text{ kg/m}^3$ . Given that the coefficient of friction between the belt and pulleys is 0.3, determine the minimum required belt width.

What would be the necessary installation force between the pulley bearings and what will be the force between the pulley bearings when the full power is transmitted?

13. A 8 mm thick leather open belt connects two flat pulleys. The smaller pulley is 300 mm diameter and runs at 200 r.p.m. The angle of lap of this pulley is  $160^\circ$  and the coefficient of friction between the belt and the pulley is 0.25. The belt is on the point of slipping when 3 kW is transmitted. The safe working stress in the belt material is  $1.6 \text{ N/mm}^2$ . Determine the required width of the belt for 20% overload capacity. The initial tension may be taken equal to the mean of the driving tensions. It is proposed to increase the power transmitting capacity of the drive by adopting one of the following alternatives :

1. by increasing initial tension by 10%, and
2. by increasing the coefficient of friction to 0.3 by applying a dressing to the belt.

Examine the two alternatives and recommend the one which will be more effective. How much power would the drive transmit adopting either of the two alternatives?

## QUESTIONS

1. Discuss the different types of belts and their material used for power transmission.
2. Discuss the various important parameters necessary for the selection of a particular drive for power transmission.
3. What are the factors upon which the coefficient of friction between the belt and the pulley depends?
4. How are ends of belts joined? For horizontal belts which side (tight or slack) of the belt should run on the top and why?
5. Explain, with the help of neat sketches, the types of various flat belt drives.
6. List and discuss briefly the factors that control the power transmission capacity of a belt.
7. Prove that the ratio of the driving tensions on the two sides of a pulley is

$$\frac{T_1}{T_2} = e^{\mu\theta}$$

where

$T_1$  = Tension in the tight side of the belt,

$T_2$  = Tension in the slack side of the belt,

$\mu$  = Coefficient of friction between the belt and the pulley, and

$\theta$  = Angle of contact in radians.

8. In a belt drive, how will you decide the pulley governing design?
9. It is stated that the speed at which a belt should be run to transmit maximum power is that at which the maximum allowable tension is three times the centrifugal tension in the belt at that speed. Prove the statement.

### OBJECTIVE TYPE QUESTIONS

1. The material suitable for the belts used in agricultural equipments is
  - (a) cotton
  - (b) rubber
  - (c) leather
  - (d) balata gum
2. The power transmitted by means of a belt depends upon
  - (a) velocity of the belt
  - (b) tension under which the belt is placed on the pulleys
  - (c) arc of contact between the belt and the smaller pulley
  - (d) all of the above
3. When the speed of belt increases,
  - (a) the coefficient of friction between the belt and pulley increases
  - (b) the coefficient of friction between the belt and pulley decreases
  - (c) the power transmitted will decrease
  - (d) the power transmitted will increase
4. In a crossed belt drive, the shafts are arranged parallel and rotate in the ..... directions.
  - (a) same
  - (b) opposite
5. The tension in the slack side of the belt is ..... the tension in the tight side of the belt.
  - (a) equal to
  - (b) less than
  - (c) greater than
6. In a flat belt drive, the belt can be subjected to a maximum tension ( $T$ ) and centrifugal tension ( $T_C$ ). The condition for transmission of maximum power is given by
  - (a)  $T = T_C$
  - (b)  $T = 2 T_C$
  - (c)  $T = 3 T_C$
  - (d)  $T = \sqrt{3} T_C$
7. When a belt drive is transmitting maximum power,
  - (a) effective tension is equal to the centrifugal tension
  - (b) effective tension is half of the centrifugal tension
  - (c) driving tension in slack side is equal to the centrifugal tension
  - (d) driving tension in tight side is twice the centrifugal tension
8. All stresses produced in a belt are
  - (a) compressive stresses
  - (b) tensile stresses
  - (c) both tensile and compressive stresses
  - (d) shear stresses
9. For maximum power, the velocity of the belt will be
  - (a)  $\sqrt{\frac{T}{m}}$
  - (b)  $\sqrt{\frac{T}{2m}}$
  - (c)  $\sqrt{\frac{T}{3m}}$
10. The centrifugal tension in the belt
  - (a) increases the power transmitted
  - (b) decreases the power transmitted
  - (c) has no effect on the power transmitted
  - (d) is equal to maximum tension on the belt

### ANSWERS

- |        |        |        |        |         |
|--------|--------|--------|--------|---------|
| 1. (b) | 2. (d) | 3. (d) | 4. (b) | 5. (b)  |
| 6. (c) | 7. (d) | 8. (b) | 9. (c) | 10. (c) |