

Chapter Three

Torsion

When regular circular shaft is subjected to torque, every cross-section in the shaft will be subjected to pure shear condition and the resisting torque which is produced from shearing stress will be equal in magnitude and having opposite direction to the using torque in deriving the torsion formula.

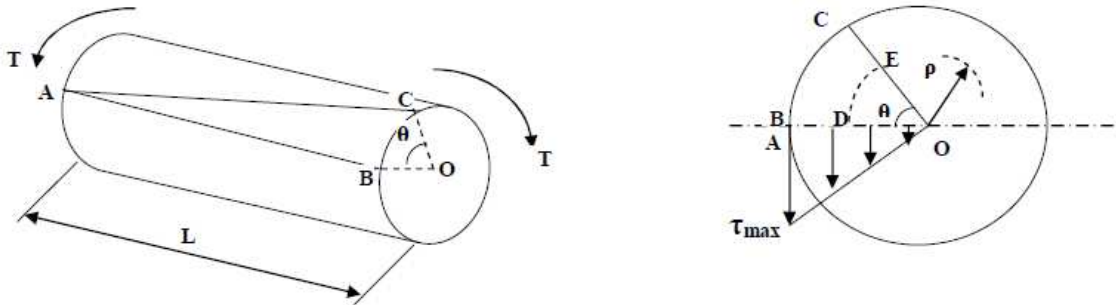

If the torque (T) is applied at the free end of the shaft, the fiber (AB) on outside surface will be twisted into (AC) as the shaft is twisted through the angle (ϕ). Consider any internal fiber located a radial distance (R) from the axis (Centre of the shaft), the radius will also rotate through angle (ϕ) causing total shearing deformation (τ) equal to arc length (DE).

$$\tau = \frac{T \times R}{J}$$

T: torque MPA

R: radius MM OR M

J: polar moment of inertia MM^4 OR M^4

To find the polar moment of inertia for solid and hollow shafts we used the following equations:

$$J = \frac{\pi r^4}{2} = \frac{\pi D^4}{32} \quad \text{(For solid shaft)}$$

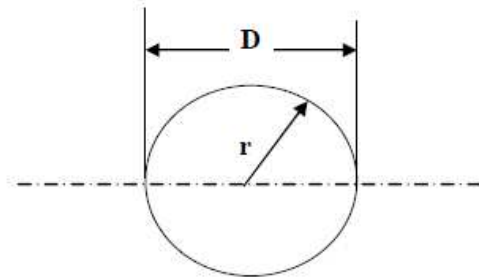

$$J = \frac{\pi}{2} (R^4 - r^4) = \frac{\pi}{32} (D^4 - d^4) \quad \text{(For hollow shaft)}$$

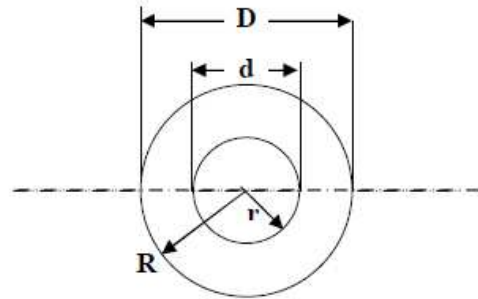

Where;

R= r_{outer}

r= r_{inner}

The maximum shear stress due to torque is at the edge of the solid objects while the minimum equal to zero. furthermore, in solid objects the we can find the maximum shear stress using outer radius (r_o)of the shaft and the inner radius(r_i) calculates the minimum stress.

SO to find the angle of twisit, we can use this formula:

$$\phi = \frac{T L}{J G}$$

where :

θ (radians) , T(N.m) , L(m) , J(m⁴) , G(N/m²)

Ex-1- A steel shaft shown in figure ($d=40\text{mm}$) is subjected to the torques as shown, determine the angle of twist of point (B) with respect to point (A) in degrees. $G_{st}=75\text{GPa}$.

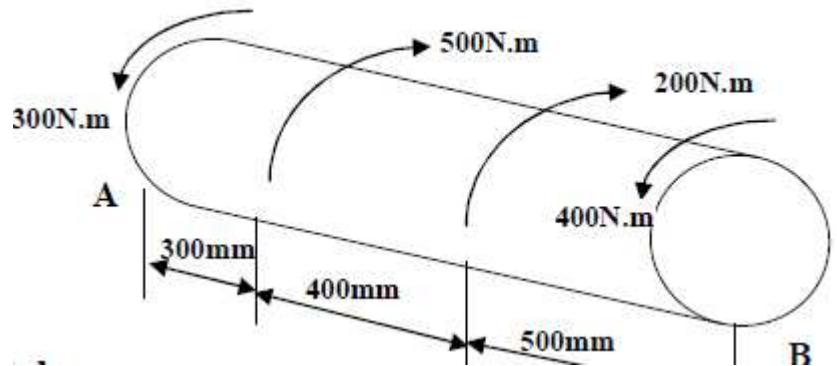

$$\phi = \sum \frac{T L}{J G}$$

For the same diameter and same material

$\Rightarrow (J, G)$ are constant

$$\therefore \phi = \frac{1}{G * J} [T_1 * L_1 + T_2 * L_2 + T_3 * L_3]$$

$$\therefore \phi_{B/A} = \frac{1}{\frac{\pi}{32} (0.04)^2 * 75 * 10^9} [400 * 0.5 + 200 * 0.4 - 300 * 0.3]$$

$$\therefore \phi = 0.01 \text{ radians}$$

$$\text{in degrees} \Rightarrow 0.01 * \frac{180}{\pi} = 0.578 \text{ degree}$$

NOTE : If two or more materials are rigidly fixed together in such way that the applied torque is shared between them.

$$\phi_t = \phi_1 + \phi_2$$

$$T_t = T_1 + T_2$$

For two fixed ends shaft ($\phi_1 + \phi_2 = 0$)

$$\therefore \phi_1 = -\phi_2$$

Ex-2- A compound shaft consisting of an aluminum segment and steel segment, is acted upon by two torques as shown in figure. determine the maximum permissible value of (T) subjected to the following conditions:

- 1) maximum shear stress in steel is (100MPa).
- 2) maximum shear stress in aluminum is (70MPa).
- 3) the angle of twist of free end is limited to (12°). ($G_{st}=83GPa$, $G_{Al}=28GPa$).

Sol :- According to shear stress

1- For steel shaft :

$$\tau_{max} = \frac{T * r}{J} = \frac{16T}{\pi * d^3}$$

$$\therefore 100 * 10^6 = \frac{16(2T)}{\pi (0.05)^3}$$

$$T = 1.23 kN.m$$

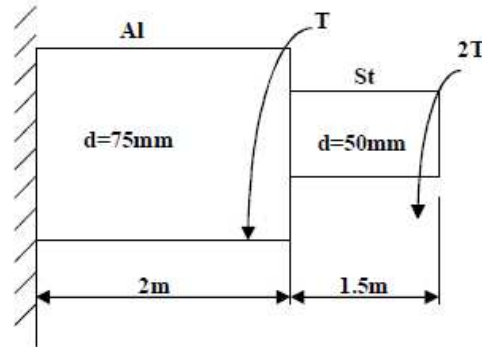

2- For aluminum shaft :

$$\tau_{max} = \frac{T * r}{J} = \frac{16T}{\pi * d^3}$$

$$\therefore 70 * 10^6 = \frac{16(3T)}{\pi (0.075)^3}$$

$$T = 1.93 kN.m$$

According to angle of twist :

$$\phi = \frac{T * L}{G * J} \quad \Rightarrow \quad \phi = \frac{T_{St} * L_{St}}{G_{St} * J_{St}} + \frac{T_{Al} * L_{Al}}{G_{Al} * J_{Al}}$$

$$\therefore \phi_{total} = \phi_{St} + \phi_{Al}$$

$$\therefore 12 * \frac{\pi}{180} = \frac{2T * 1.5}{\frac{\pi}{32} (0.05)^4 * 83 * 10^9} + \frac{3T * 2}{\frac{\pi}{32} (0.075)^4 * 28 * 10^9} \Rightarrow T = 1.638 kN.m$$

\therefore Maximum (T) is (1.23 kN .m) are can be used

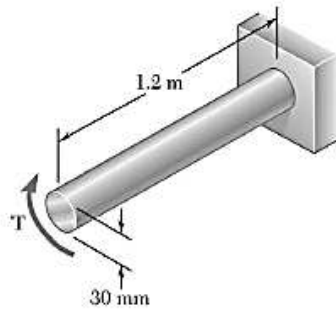

The solid shaft shown is made of a mild steel that is assumed to be elastoplastic with $G = 77.2 \text{ GPa}$ and $\tau_Y = 145 \text{ MPa}$. Determine the angle of twist caused by the application of a torque of magnitude (a) $T = 600 \text{ N} \cdot \text{m}$, (b) $T = 1000 \text{ N} \cdot \text{m}$.

ANS/ $\varphi = 18.71^\circ$
 $\varphi = 6.72^\circ$

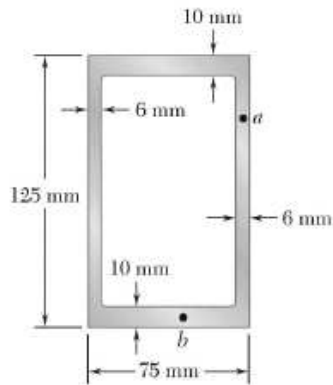

A torque $T = 5 \text{ kN} \cdot \text{m}$ is applied to a hollow shaft having the cross section shown. Neglecting the effect of stress concentrations, determine the shearing stress at points a and b .

SOLUTION

$$T = 5 \times 10^3 \text{ N} \cdot \text{m}$$

Area bounded by centerline.

$$a = bh = (69)(115) = 7.935 \times 10^3 \text{ mm}^2$$

$$= 7.935 \times 10^{-3} \text{ m}^2$$

At point a :

$$t = 6 \text{ mm} = 0.006 \text{ m}$$

$$\tau = \frac{T}{2ta} = \frac{5 \times 10^3}{(2)(0.006)(7.935 \times 10^{-3})}$$

$$= 52.5 \times 10^6 \text{ Pa}$$

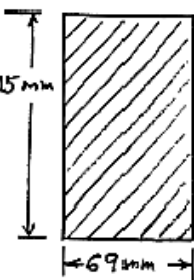

$$\tau = 52.5 \text{ MPa} \quad \blacktriangleleft$$

At point b :

$$t = 10 \text{ mm} = 0.010 \text{ m}$$

$$\tau = \frac{T}{2ta} = \frac{5 \times 10^3}{(2)(0.010)(7.935 \times 10^{-3})} = 31.5 \times 10^6 \text{ Pa}$$

$$\tau = 31.5 \text{ MPa} \quad \blacktriangleleft$$

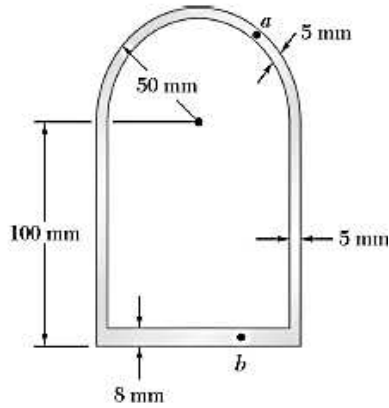

A 5.6 kN ·m torque is applied to a hollow shaft having the cross section shown. Neglecting the effect of stress concentrations, determine the shearing stress at points *a* and *b*.

SOLUTION

Area bounded by centerline.

$$a = (96\text{ mm})(95\text{ mm}) + \frac{\pi}{2}(47.5\text{ mm})^2 = 12.664 \times 10^3 \text{ mm}^2$$

$$= 12.664 \times 10^{-3} \text{ m}^2$$

At point *a*, $t = 5\text{ mm} = 0.005\text{ m}$

$$\tau = \frac{T}{2at} = \frac{5.6 \times 10^3}{(2)(12.664 \times 10^{-3})(0.005)} = 44.2 \times 10^6 \text{ Pa} \quad \tau = 44.2 \text{ MPa} \blacktriangleleft$$

At point *b*, $t = 8\text{ mm} = 0.008\text{ m}$

$$\tau = \frac{T}{2at} = \frac{5.6 \times 10^3}{(2)(12.664 \times 10^{-3})(0.008)} = 27.6 \times 10^6 \text{ Pa} \quad \tau = 27.6 \text{ MPa} \blacktriangleleft$$