

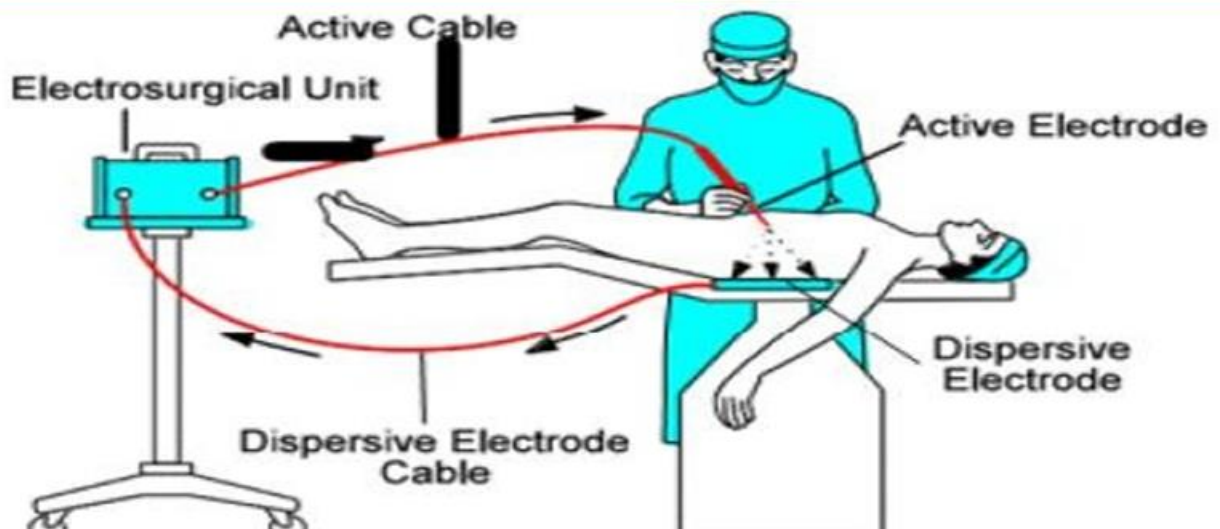

➤ **Electrosurgical unit (ESU):**

- **An electrosurgical unit (ESU)** passes high-frequency electric currents through biologic tissues to achieve specific surgical effects such as cutting, coagulation, or desiccation. It has been used since the 1920s to cut tissue effectively while at the same time controlling the amount of bleeding.
- **Cutting** is achieved primarily with a continuous sinusoidal waveform, whereas **coagulation** is achieved primarily with a series of sinusoidal wave packets. An electrosurgical unit can be operated in two modes, the monopolar mode and the bipolar mode. The most difference between these two modes is the method in which the electric current enters and leaves the tissue.



Theory of operation

In principle, electrosurgery is based on the rapid heating of tissue. To better understand the thermodynamic events during electrosurgery, it helps to know



Al-Mustaqbal University College
Department of Medical Instrumentation Techniques Engineering
Class: Second Class
Subject: **Electrosurgical unit**
Lecturer: MSc. Mohammed Tareq Fakhri
Lecture: Ninth Lecture

the general effects of heat on biologic tissue. Consider a tissue volume that experiences a temperature increase from normal body temperature to 45°C within a few seconds.

The cytochemical changes do in fact occur. However, these changes **are reversible**, and the cells return to their normal function when the temperature returns to normal values. **Above 45°C, irreversible** changes take place that inhibit normal cell functions and lead to cell death. **First, between 45°C and 60°C**, the *proteins* in the cell lose their quaternary **out**, configuration and solidify into a glutinous substance, this process, termed coagulation, are accompanied by tissue blanching. **Further** increasing the temperature up to 100°C leads to tissue drying this process is called **desiccation**. If the temperature is increased beyond 100°C, the solid contents of the tissue reduce to carbon, a process referred to as carbonization. Tissue damage depends not only on temperature, however, but also on the length of exposure to heat.

In the **monopolar mode**, the active electrode either touches the tissue directly or is held a few millimeters above the tissue. When the electrode is held above the tissue, the electric current bridges the air gap by creating an electric discharge arc. A visible arc forms when the electric field strength exceeds 1 kV/mm in the gap and disappears when the field strength drops below a certain threshold level.

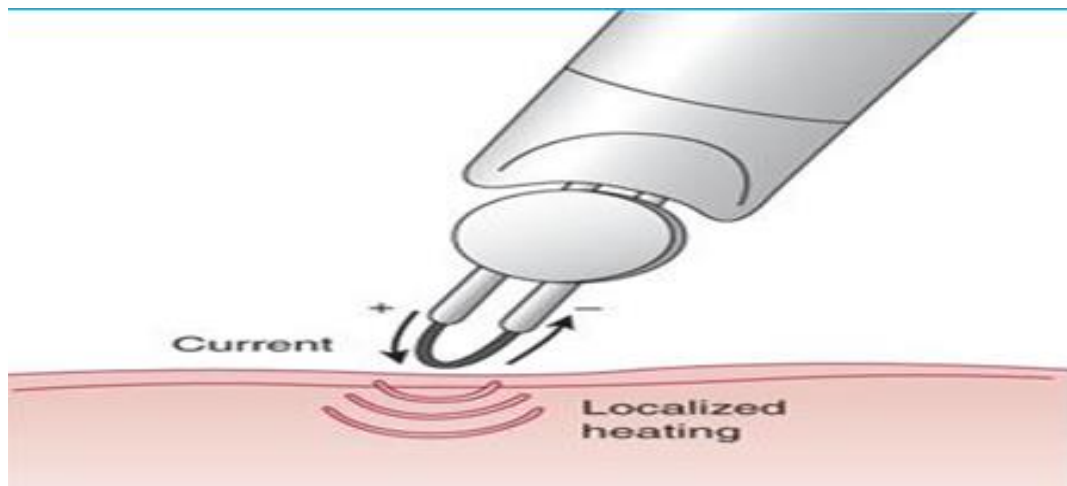

Monopolar Electrosurgical

In monopolar electrosurgery, tissue is cut and coagulated by completing an electrical circuit that includes a high-frequency oscillator and amplifiers within the ESU, the patient plate, the connecting cables, and the electrodes. In most applications, electric current from the ESU is conducted through the surgical site with an active cable and electrode. The electrosurgical current is then dispersed through the patient to a return electrode returning the energy to the generator to complete the path. Monopolar electrosurgery has the means of delivering energy to the tissue through several Modalities (modes of operation): pure cut, blended cut desiccation (or pinpoint), and spray (or fulguration). The delivery system of the monopolar electrosurgical generator can be a hand controlled pencil (reusable or disposable) or a foot controlled pencil. A number of accessories can be adapted to the foot control output jack to deliver energy through a number of instruments.

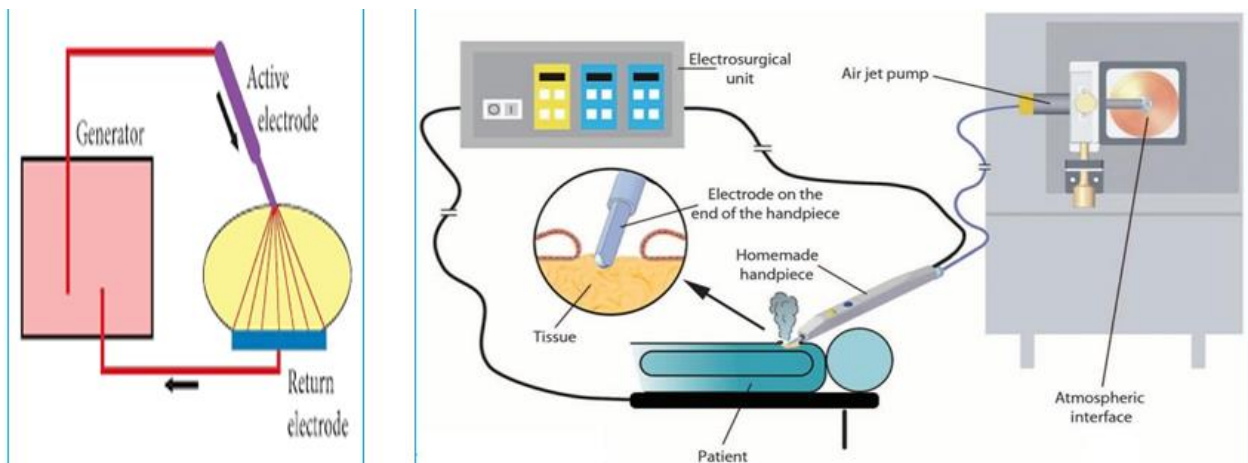



Al-Mustaqbal University College
Department of Medical Instrumentation Techniques Engineering
Class: Second Class
Subject: **Electrosurgical unit**
Lecturer: MSc. Mohammed Tareq Fakhri
Lecture: Ninth Lecture

Bipolar Electrosurgery

In bipolar electrosurgery, two electrodes (generally the tips of a pair forceps or scissors) serve as the equivalent of the active and dispersive leads in the monopolar mode. Bipolar electrosurgery does not require a patient plate. Electrosurgical current in the patient is restricted to a small volume of tissue in the immediate region of application of the forceps. This affords greater control over the area to be coagulated. Damage to sensitive tissues in close proximity to the instrument can be avoided. There is less chance of current capacitive or directly arcing to surrounding structures such as the bowel. Patient burns are virtually eliminated.

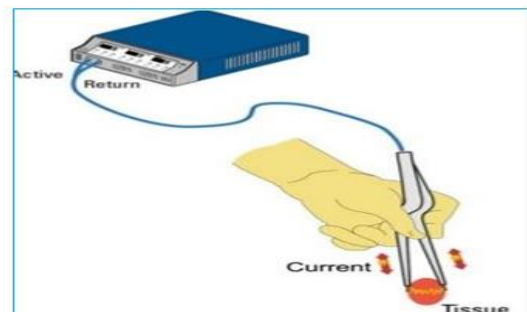
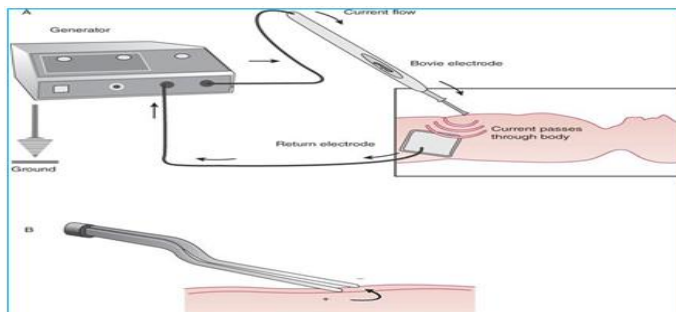

Dispersive electrodes

A dispersive electrode is an electrode with a relatively large surface area which is positioned on the patient in order to allow the high frequency current to flow back with a low current intensity in order to prevent any physical effects, such as undesired burns.



Al-Mustaqbal University College
Department of Medical Instrumentation Techniques Engineering
Class: Second Class
Subject: **Electrosurgical unit**
Lecturer: MSc. Mohammed Tareq Fakhri
Lecture: Ninth Lecture

Over the years electrosurgery has advanced, so too have the types and styles of dispersive electrodes. Early on in electrosurgery the only choice was a solid pad (at first a stainless steel plate) that was placed on the patient to disperse the heat of the RF energy. If the solid plate was not applied correctly or began to move off the patient during the case, the ESU would continue to deliver energy to the tissue, causing a potentially dangerous situation.

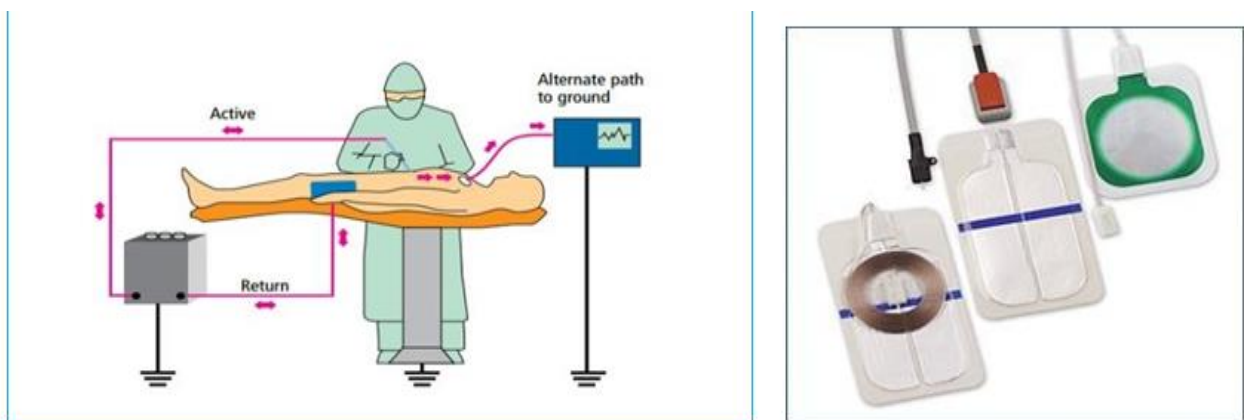

Current Density

Electrosurgery makes use of an intensely concentrated current **to induce a heat energy** that is capable of a range of effects: from the drying out of cells with consequent coagulation of blood, to the vaporization of cells. Permitting an electrode to physically separate a path through living tissue. The degree of current concentration is called "**current density**."

Current density is one of the most important concepts in electrosurgery. Simply stated, current density is the amount of current concentration at a given point. In electrosurgery, all of the **RF current** is forced to flow through the tiny area where the active electrode makes contact with the skin. At this point, the current flow is concentrated intensely.



Al-Mustaqbal University College
Department of Medical Instrumentation Techniques Engineering
Class: Second Class
Subject: **Electrosurgical unit**
Lecturer: MSc. Mohammed Tareq Fakhri
Lecture: Ninth Lecture

The heat at the site is great enough to achieve cutting and coagulation. Current leaves the body via a dispersive electrode (grounding pad).

The pad has a large surface area thus the current density is quite low. As long as this large, so-called "dispersive" electrode makes good contact with the skin it should offer a passage of least resistance for safe exit of the RF current from the patient. The large surface area generates little heat. A generator supplies RF to the active electrode. Current passes through the patient, exiting by way of the return electrode. It returns to the generator to complete the circuit. Without complete circular path, from generator to patient, back to the generator, the current should not flow.

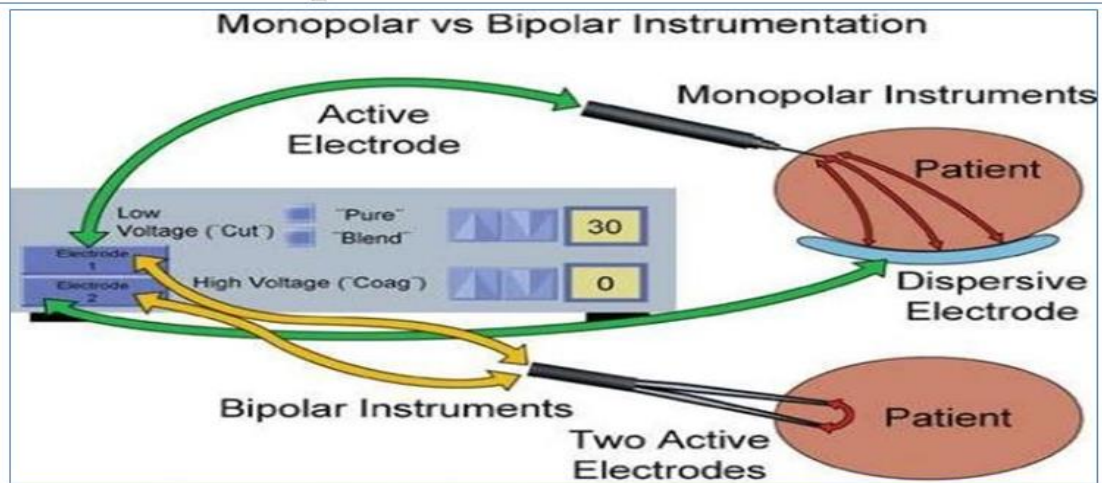
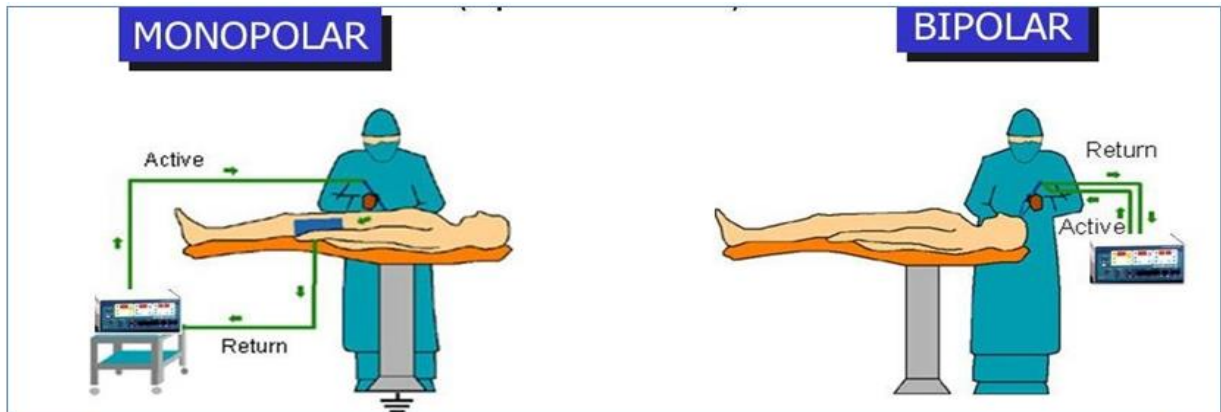



ESU waveform:

ESU generators are able to produce a variety of electrical waveforms. As a waveform change, so will the corresponding tissue effect. Using a constant waveform, like "cut", the surgeon is able to vaporize or cut tissue. This waveform produces heat very rapidly. Using an intermittent waveform like "coagulation", cause the generator to modify the waveform so that the duty cycle "ON time" is reduced. This interrupted waveform will produce less heat, instead of tissue vaporization, a coagulum produced.

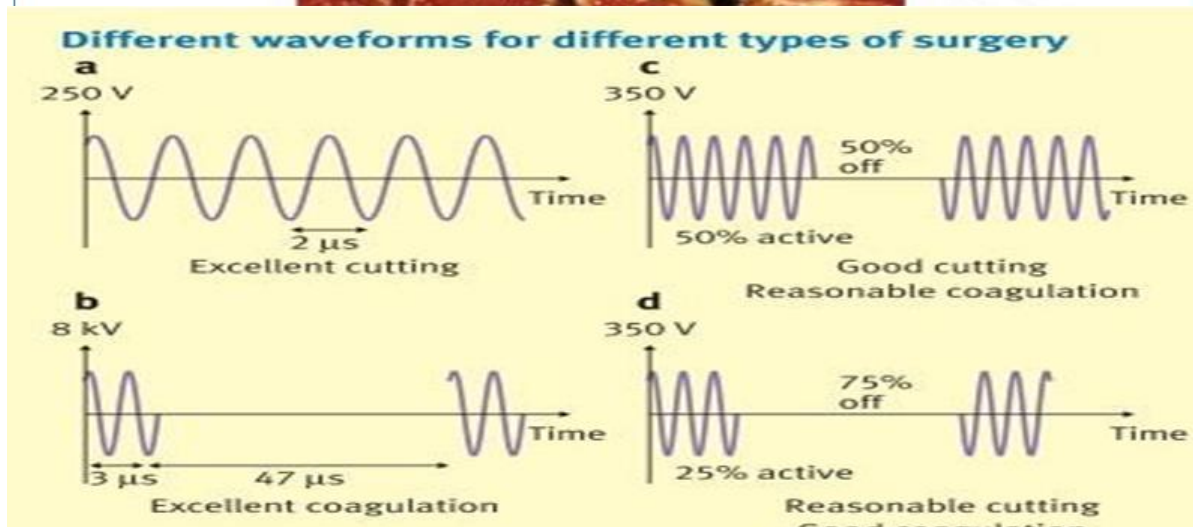
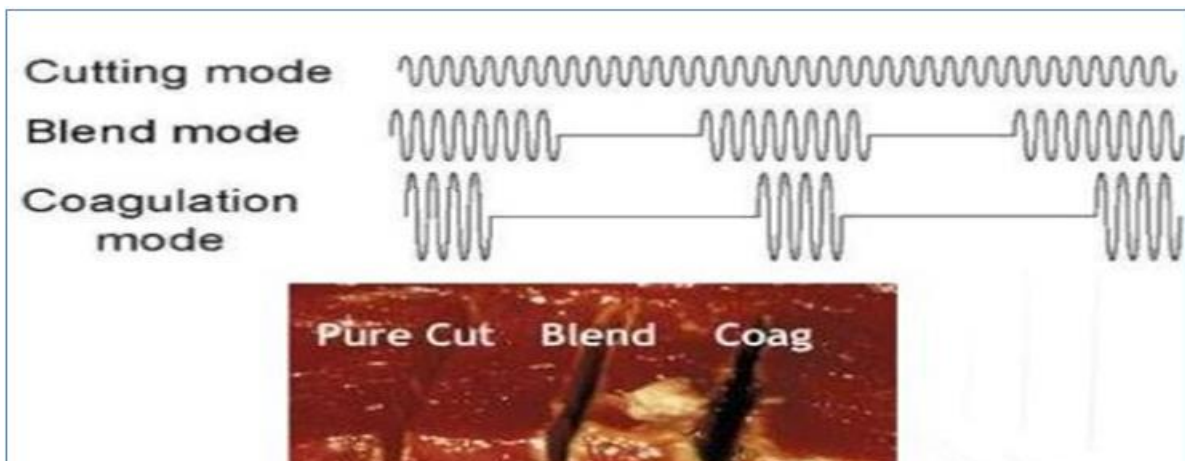

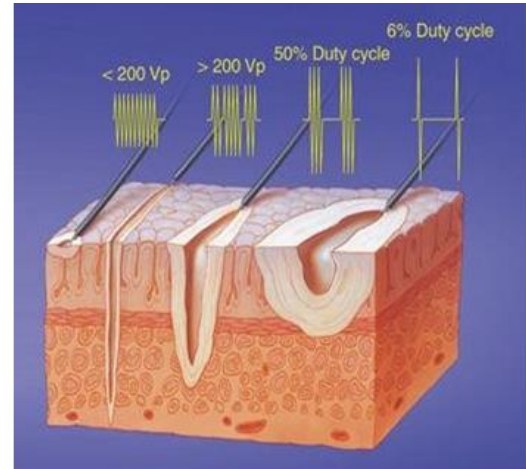
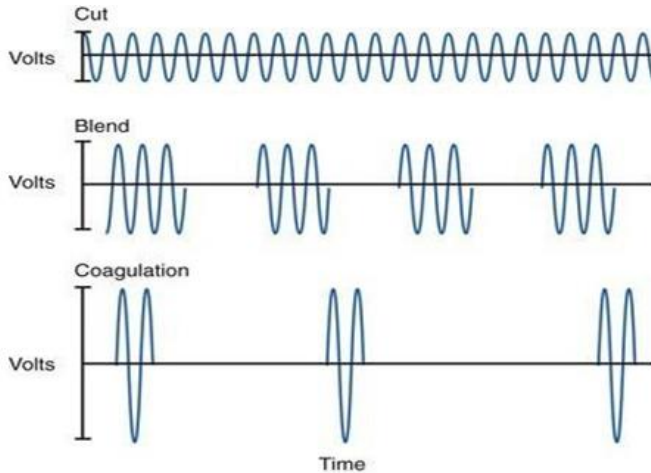

Spark gap circuits

The first electrosurgical instrument used spark gap technique and figure below shows the principle of work of spark gap instrument. Consist of high voltage transformer and electric spark gap and C 1/L1 circuit. **The transformer** will increase the voltage from 220 v to 3000-4000v which is able to ionize the air in the gap between the two points oftungsten. When **the gap**-start to spark during production of electric arc by alternating pattern, it will produce currents which radio frequencies which start to oscillate in the circuit **(C1/L1)**. This circuit is coupled "connect" with output circuit **(L1/L2)** by induction. The output energy which gone to the patient can be control its intensity through taken different level of energy from L2 through switch S2 which is connect with the active electrode. Depending on the type and design of the instrument the poweris between 25 watt and few hundred watts. **The coils RF1 and RF2** are used for protection and prevent the effect or return back of radio frequencies to the input power.

In some instrument **the capacitor** is used parallel with the secondary coil of thetransformer T1.

These generators are used in cauterization and coagulation to stop the bleeding from blood vessels. Most of these instruments exist in two mode cut and coagulate. The rough foot selector switch. The wave for cutting is pure sinusoidal wave while the coagulation wave is damped oscillation wave according to the type and technique of the instrument.

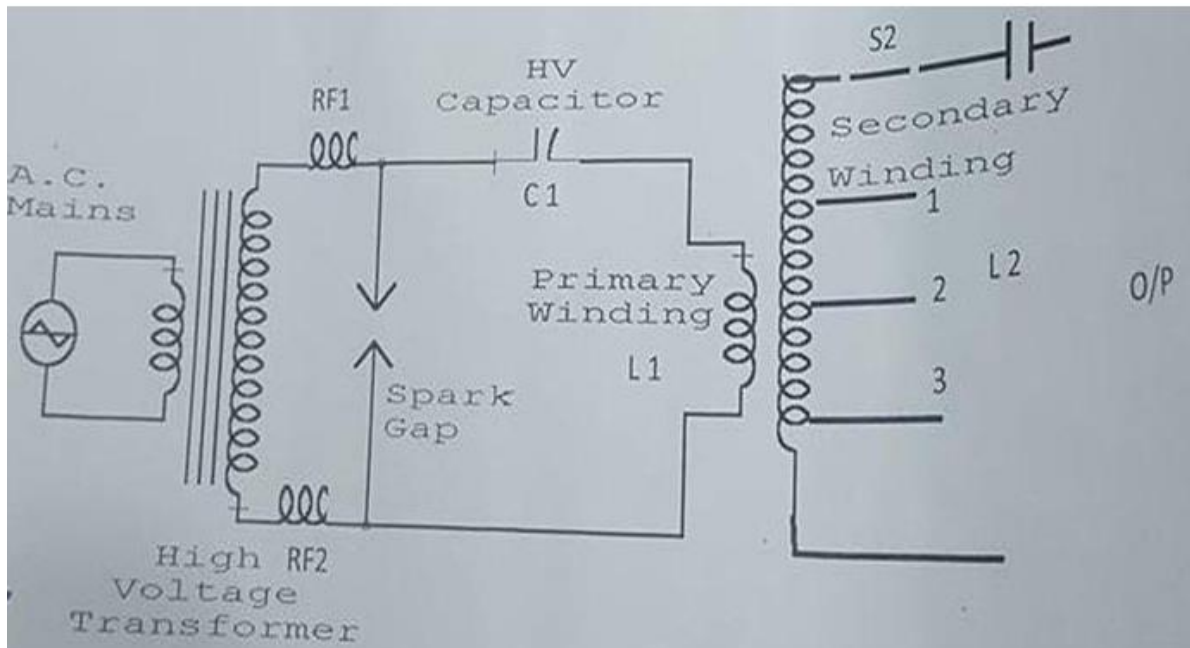

2) Electronics circuits for electro surgery "solid-state circuit":

The electronics circuits are used now in electrosurgical instruments so its small in size and weight, the circuit in (figure below) is one of the types of amplifier of the power of radio frequency.

The circuit is **push-pull/parallel circuit**. There are two row or sides of **3 transistors** from Q1 -Q3 "the first", and from Q4_ Q6 "the second". Each three transistors are connected parallel, and the two row are connected by push-pull circuit. The transformers used in the circuit in a form of "toroid-shaped" to determine the magnetic field in the circuit.

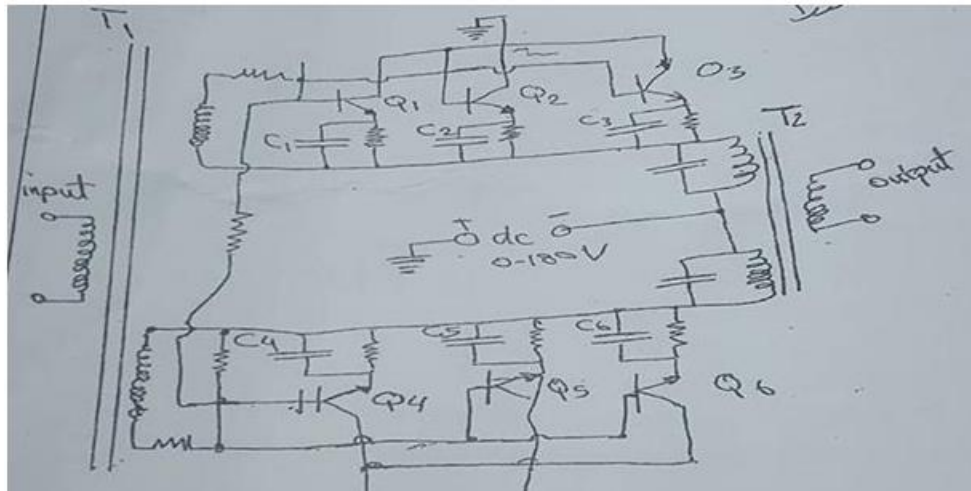

The radio frequency signal can be produced by Oscillator as shown in figure below. When the transistor (**Q1**) in forward deviation state, the circuit will be oscillate with radio frequency according the value of circuit's element. The transistor (**Q2**) works as control switch to control (Q1). When the (Q2) works, it caused to (Q1) works also "forward deviation". In the cutting mode the (Q2) continue working and the output signal is continuous sinusoid / wave (figure below), but during coagulation moderectangular wave is given to the base of transistor (Q2) which is going to cut it to produce chopped sinusoid wave (figure below). There are another circuits used another technique according to the manufacture company.

