



Experiment No.4

Delta– Star Connection

1. Introduction

1.1 Objective:

To verify the equivalence between star connection and delta connection for the resistor networks.

1.2 Components:

- DC power supply.
- Electrical and electronic system trainer.
- Connecting wire.
- Multimeter.

1.3 Theory

Circuit configurations are often encountered in which the resistors do not appear to be in series or parallel. Under these conditions, it may be necessary to convert the circuit from one form to another. Two circuit configurations that often account for these difficulties are the Y (Y) interconnection because the interconnection can be shaped to look like the letter Y. The (Y) configuration also is referred to as tee (T) structure without disturbing the electrical equivalence of the two structures and delta (Δ) in which the interconnection looks like the Greek letter (Δ). It also is referred to as pi (Π) interconnection without disturbing the electrical equivalence of the two configurations depicted in Figures 1 and 2.

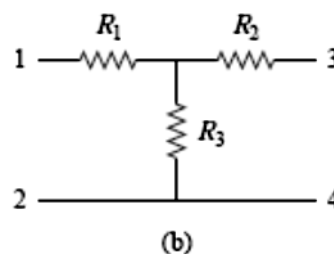
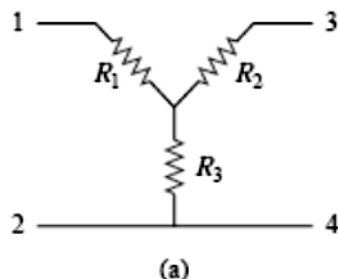

Figure 1 Two forms of the same network: (a) Y, (b) T.

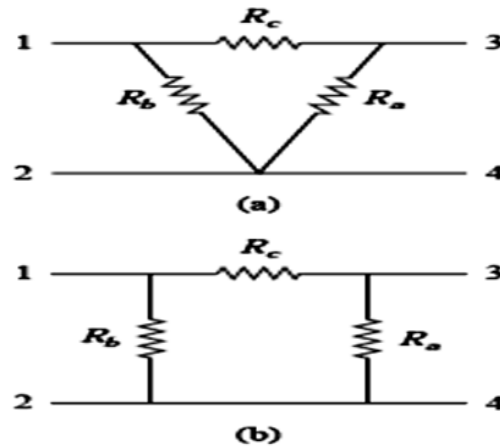

Figure 2 Two forms of the same network: (a) Δ , (b) π .

Delta to Wye Conversion

Suppose it is more convenient to work with a **wye** network in a place where the circuit contains a delta configuration. We superimpose a **wye** network on the existing **delta** network and find the equivalent resistances in the **wye** network. For terminals 1 and 2 in **Figs. 1** and **2**

$$R_1 = \frac{R_b R_c}{R_a + R_b + R_c}$$

$$R_2 = \frac{R_c R_a}{R_a + R_b + R_c}$$

$$R_3 = \frac{R_a R_b}{R_a + R_b + R_c}$$

Wye to Delta Conversion

Reversing the Δ -to-Y transformation also is possible. That is, we can start with the Y structure and replace it with an equivalent Δ structure. The expressions for the three Δ -connected resistors as functions of the three Y-connected resistors are

$$R_a = \frac{R_1 R_2 + R_2 R_3 + R_3 R_1}{R_1}$$

$$R_b = \frac{R_1 R_2 + R_2 R_3 + R_3 R_1}{R_2}$$

$$R_c = \frac{R_1 R_2 + R_2 R_3 + R_3 R_1}{R_3}$$

2. Experiment procedure:

1. Using the DC circuit trainer, connect the circuit shown in Fig. 3.

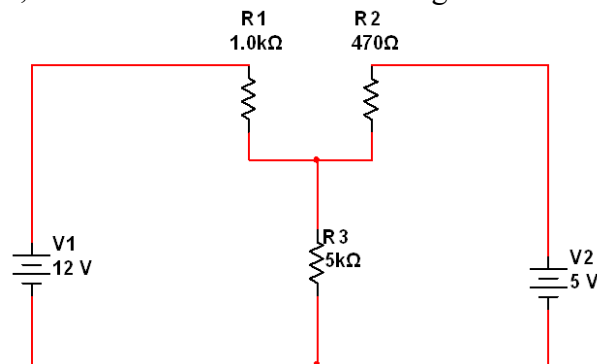

Fig. 3: Y circuit.

2. Use the multimeter to measure the currents in each branch.
3. Convert the Y circuit in Fig. 3 to delta connection theoretically.
4. Using the DC circuit trainer, connect the circuit shown in Fig. 4.

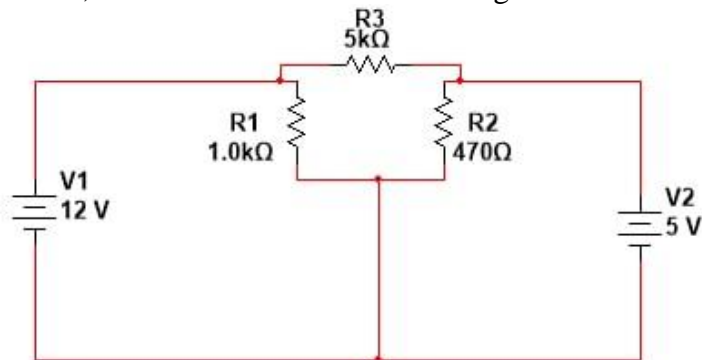

Fig. 4: Delta circuit.

5. Repeat. step 2 and convert it to the equivalent Y circuit.

3. Discussion

1. Why do we convert Wye to Delta or Delta to Wye?
2. What is the difference between delta and star-delta? And, Which current is higher Star or Delta?

- 3. Did the power delivers from (DC power supply) is changed after using the conversion from A to Y. Prove that?
- 4. Find R_T for the circuit below in Fig. 5.
- 5. Find I_T for the circuit below in Fig. 6.

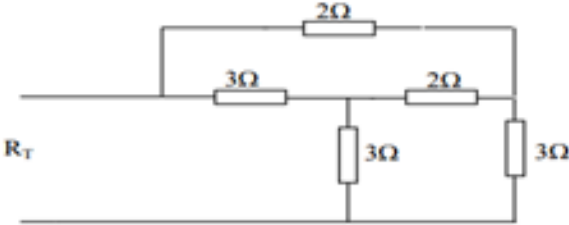

Fig. 5

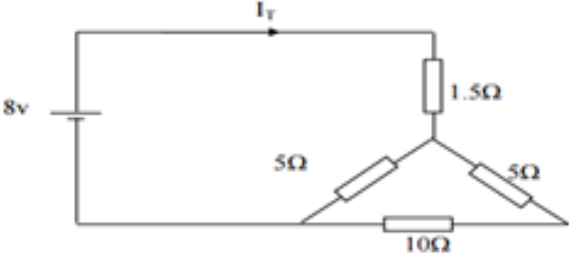

Fig. 6