



جامعة المستقبل  
AL MUSTAQBAL UNIVERSITY



# Analog Electronics

**Prof. Dr. Ehssan Al-Bermamy**

[ihsan.zia@uomus.edu.iq](mailto:ihsan.zia@uomus.edu.iq)

**1<sup>st</sup> semester**

# **Chapter Two**

## **Diode and its Application**

### **Lecture 4**

## V-I Characteristic for Reverse Bias

With **0 V** reverse voltage, there is **no reverse current**.

There is **only** a **small current through the junction** as the **reverse voltage increases**.

**At a point**, the **reverse current shoots up** with the diode's breakdown. The voltage is called the **breakdown voltage**.

This is **not a normal mode of operation**.

**After this point**, the **reverse voltage remains approximately  $V_{BR}$** , **but IR increases rapidly**.

**Break-down voltage depends** on the **doping level**, set by the manufacturer.

Combine the curves for both forward bias and reverse bias, and you have the **complete V-I characteristic** curve for a diode, as shown in Figure 6.

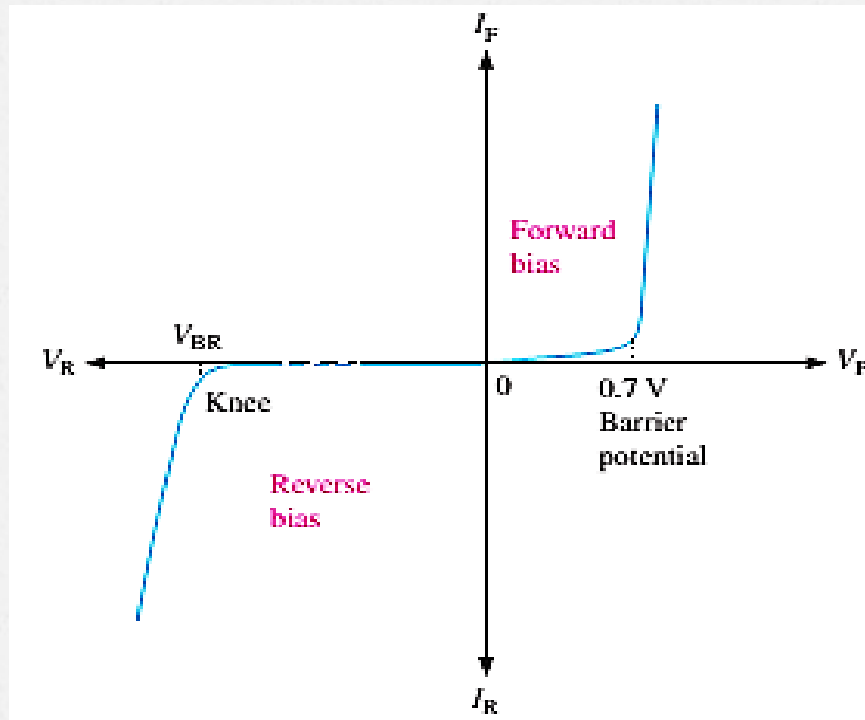

## ▪ Diode models

### A- The **Ideal Diode Mode**

1- When the diode is **forward-biased**, it ideally acts like a **closed (on) switch**, as shown in Figure 7.

2- When the diode is **reverse-biased** ideally acts like an **open (off) switch**, as shown in part (b).

The barrier potential, the **forward dynamic resistance**, and the **reverse current** are **neglected**.

In Figure 7c, the ideal V-I characteristic curve graphically depicts the ideal diode operation.

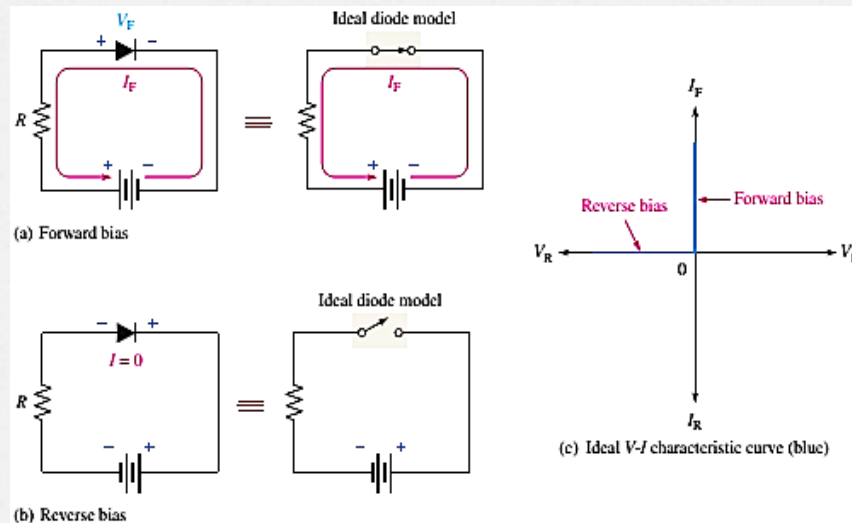

## B- The **Practical** Diode Model

- The **practical model** includes the **barrier potential**. The characteristic curve for the practical diode model is shown in Figure 8c.
- Since the **barrier potential** is included and **the dynamic resistance is neglected**, the diode is assumed to have a voltage across it when forward-biased, as indicated by the curve to the right of the origin.
- The **practical model** is useful in **lower-voltage circuits** and **designing basic diode circuits**. The **forward current** is determined using **first Kirchhoff's voltage law** to Figure 8a:

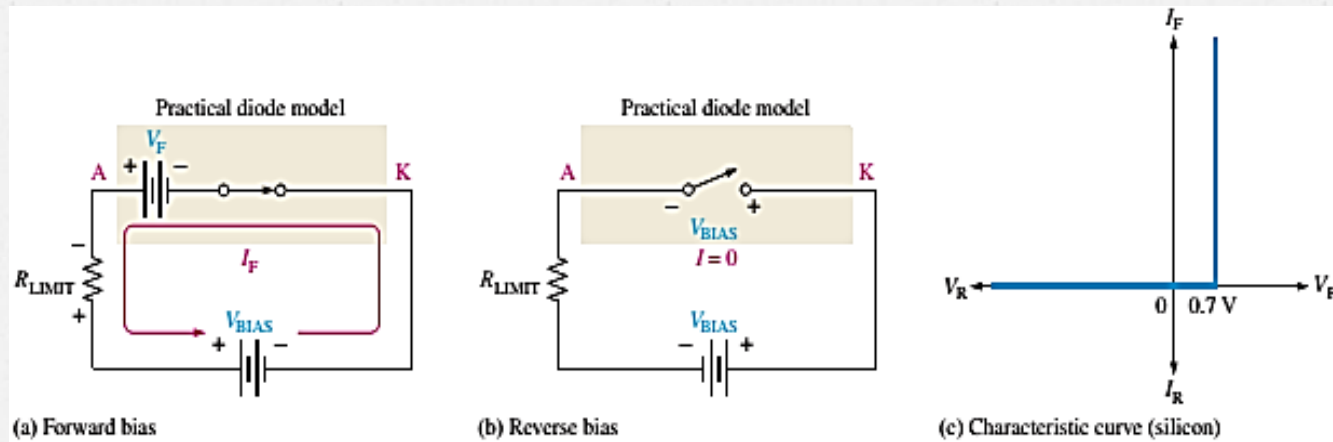

$$V_{BIAS} - V_F - V_{R_{LIMIT}} = 0$$

$$V_{R_{LIMIT}} = I_F R_{LIMIT}$$

Substituting and solving for  $I_F$

$$I_F = \frac{V_{BIAS} - V_F}{R_{LIMIT}}$$

The diode is assumed to have zero reverse current,

$$V_F = 0.7V, \quad V_R = V_{BIAS}, \quad I_R = 0A$$

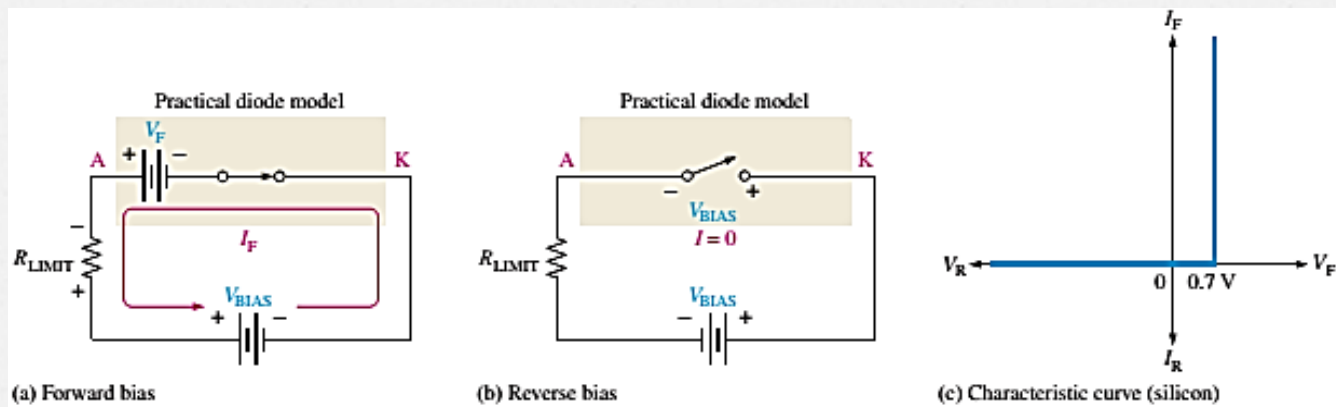

Example 1: (a) Determine the forward voltage and forward current for the diode in Figure 10 (a) for each of the ideal and practical diode models. Also, find the voltage across the limiting resistor in each case.

(b) Determine the diode's reverse voltage and current in Figure 10(b) for each diode model. Also, find the voltage across the limiting resistor in each case. Assume  $I_R = 1\mu\text{A}$ . (H.W.)

(a) Ideal model:

$$V_F = 0\text{ V}$$

$$I_F = \frac{V_{\text{BIAS}}}{R_{\text{LIMIT}}} = \frac{10\text{ V}}{1.0\text{ k}\Omega} = 10\text{ mA}$$

$$V_{R_{\text{LIMIT}}} = I_F R_{\text{LIMIT}} = (10\text{ mA})(1.0\text{ k}\Omega) = 10\text{ V}$$

Practical model:

$$V_F = 0.7\text{ V}$$

$$I_F = \frac{V_{\text{BIAS}} - V_F}{R_{\text{LIMIT}}} = \frac{10\text{ V} - 0.7\text{ V}}{1.0\text{ k}\Omega} = \frac{9.3\text{ V}}{1.0\text{ k}\Omega} = 9.3\text{ mA}$$

$$V_{R_{\text{LIMIT}}} = I_F R_{\text{LIMIT}} = (9.3\text{ mA})(1.0\text{ k}\Omega) = 9.3\text{ V}$$

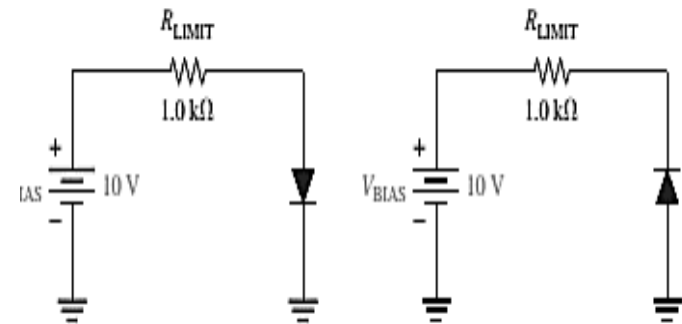

(b)



- **The DC power supply**

- A **power supply** is an essential part of each electronic system from the simplest to the most complex. A basic block diagram of the complete power supply is shown in the below Figure.

- The **transformer changes AC voltages based on the turn's ratio between the primary and secondary.**

- The **rectifier converts the ac input voltage to dc voltage.**

- The **filter eliminates the fluctuations in the rectified voltage and produces a relatively smooth dc voltage.**

- The **regulator is a circuit that maintains a constant dc voltage for variations in the input line voltage or in the load.**

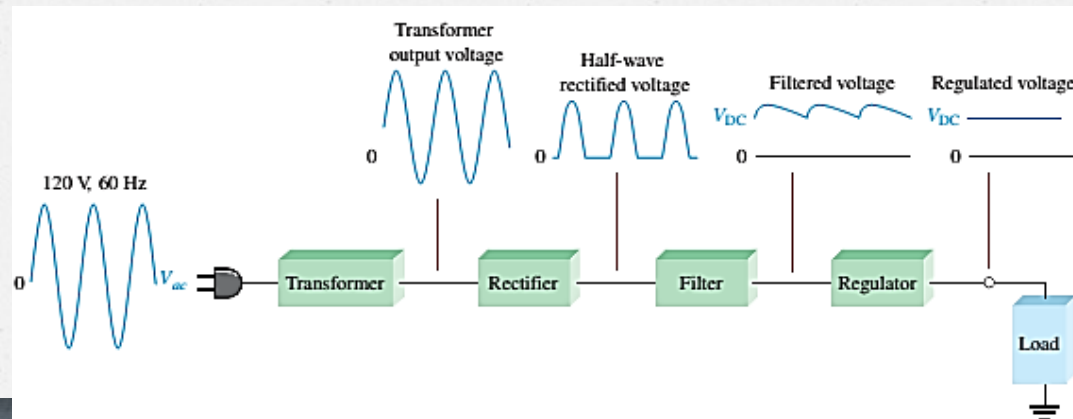

## ■ Half-Wave Rectifiers

- Because of their **ability** to **conduct current in one direction** and **block current in the other direction**, diodes are used in circuits called rectifiers that convert **AC** voltage into **DC** voltage.
- **Rectifiers** are found in all **DC power** supplies that operate from an AC voltage source.
- When **connected with AC voltage**, the **diode** only allows **half a cycle to pass** through it, converting **AC into DC**.
- As **half of the wave gets rectified**, the process is called **half-wave rectification**. The output frequency is the same as the input.

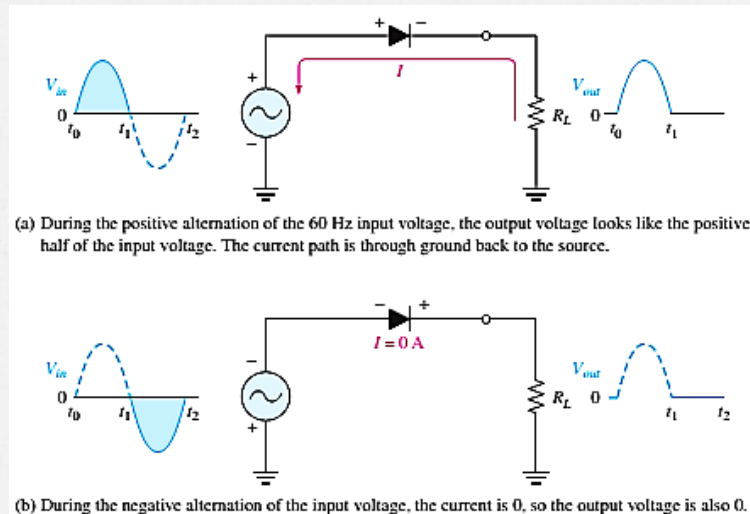

- The average value ( $V_{AVG}$ ) of half-wave rectified voltage **if its peak amplitude is 50 V is**

$$V_{AVG} = V_p / \pi = 50 / 3.14 = 15.9 \text{ V}, V_{AVG} \text{ is approximately } 31.8\% \text{ of } V_p$$

$$P_{IV} = V_p(\text{in})$$

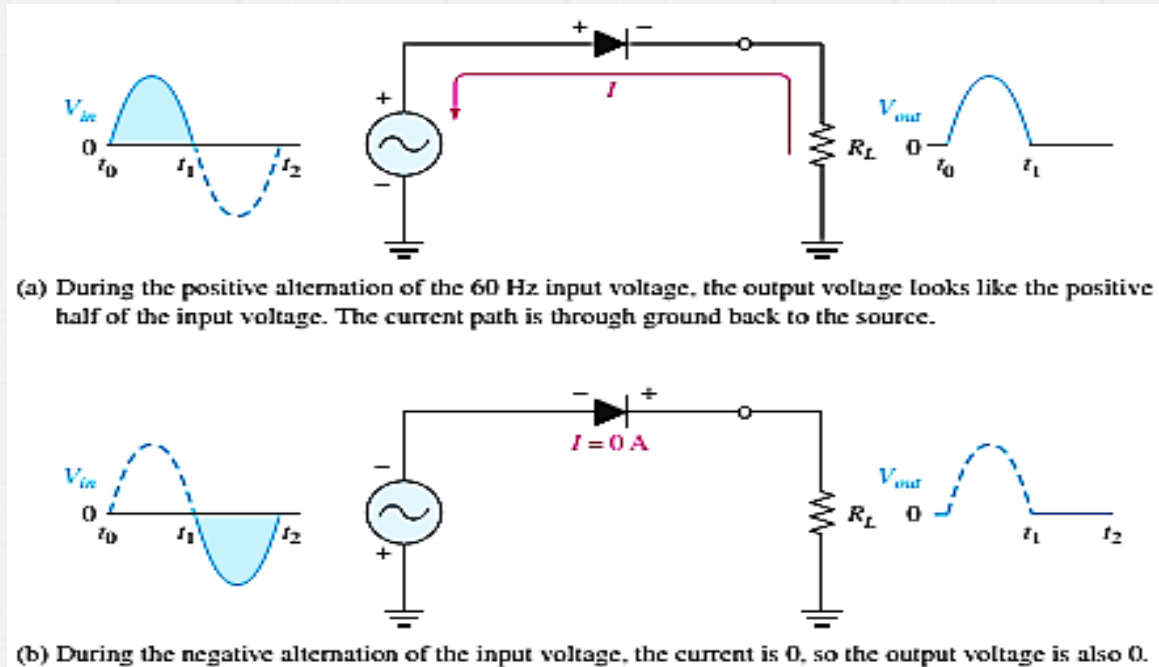

- $P_{IV}$ : Peak **inverse voltage** = is the **maximum** voltage that occurs at the peak of each half-cycle of the input voltage when the diode is reverse-biased.
- The diode must be **capable of withstanding** this amount of voltage.

Figure 13

