



Lecture 2

Introduction to Signals and Systems

1.1 Introduction

The goal of this lecture is to introduce the concepts of signals and systems, and to provide a foundation for the later lectures. However, we will look at the above concepts in details as follow.

Signals constitute an important part of our daily life. Anything that carries some information is called a signal. A signal is defined as a physical quantity that varies with time, space or any independent variable. A signal may be represented in time domain or frequency domain.

System is defined as a set of elements or fundamental blocks which are connected together and produces an output in response to an input signal. Systems may be single-input and single output systems or multi-input and multi-output systems.

The process of communication involves:

- Generation of signal.
- Transmission of signal.
- Reception of signal.



1.2 Classification of Signals

There are several classes of signals. Anyway, we shall consider the following classes, which are required in next lectures.

- Continuous-Time and Discrete-Time Signals.
- Analog and Digital Signals.
- Periodic and Aperiodic Signals.
- Even and Odd Signals.
- Deterministic and Random Signals.
- Energy and power signals.

1.3 Continuous-Time and Discrete-Time Signals

If a signal is defined for all values of the independent variable t , it is called a continuous time signal. On the other hand, if a signal is defined only at discrete values of time, it is called a discrete-time signal.

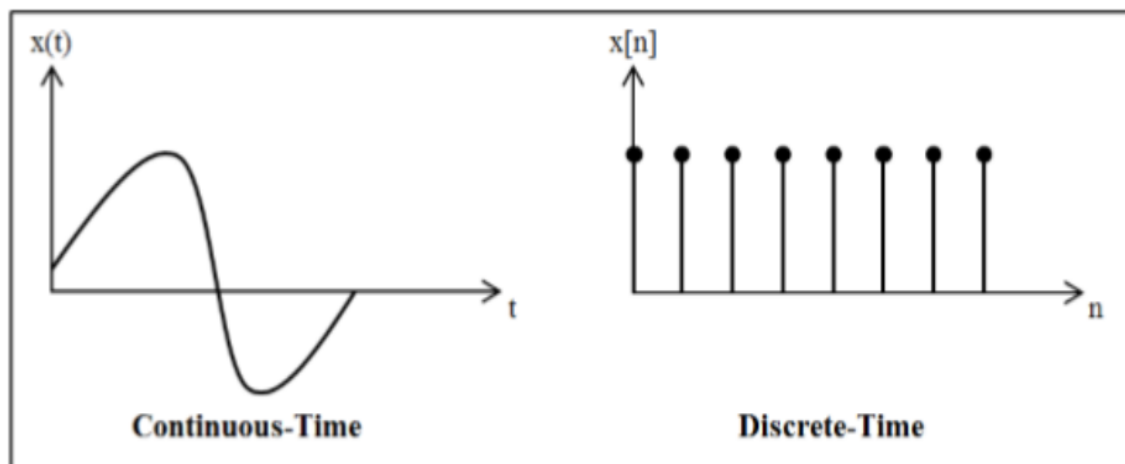



Analog and Digital Signals

A second classification of signals is based on their amplitudes. The amplitudes of many real-world signals, such as voltage and current, change continuously, and these signals are called analog signals. Digital signals, on the other hand, can only have a finite number of amplitude values. A common example of a digital signal is binary sequence.

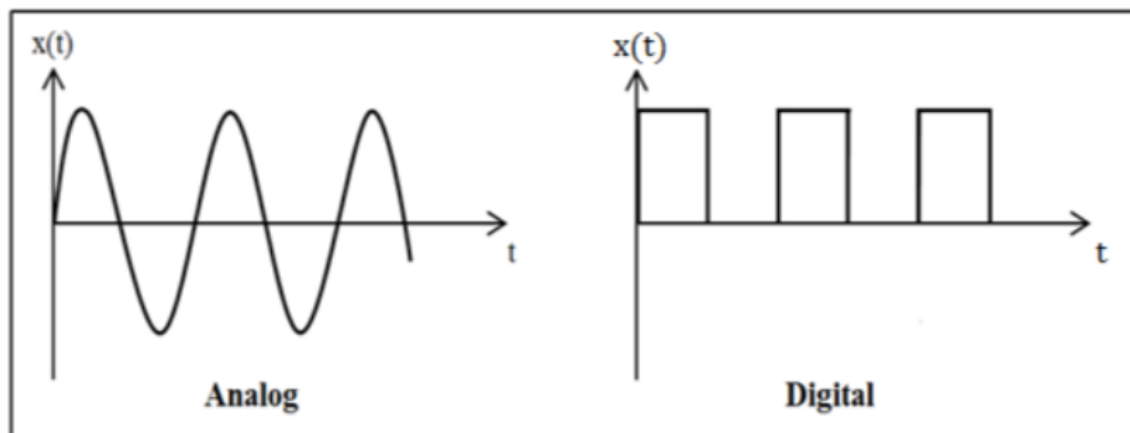

Periodic and Aperiodic Signals:

A signal which repeats itself after a specific interval of time is called Periodic signal, while a signal which does not repeat itself after a specific interval of time is called Aperiodic signal. In other word, a signal $x(t)$ is Periodic signal if $x(t) = x(t + nT)$, where T is called the period and the integer $n > 0$. But if $x(t) \neq x(t + nT)$ then $x(t)$ is a non-periodic or aperiodic.

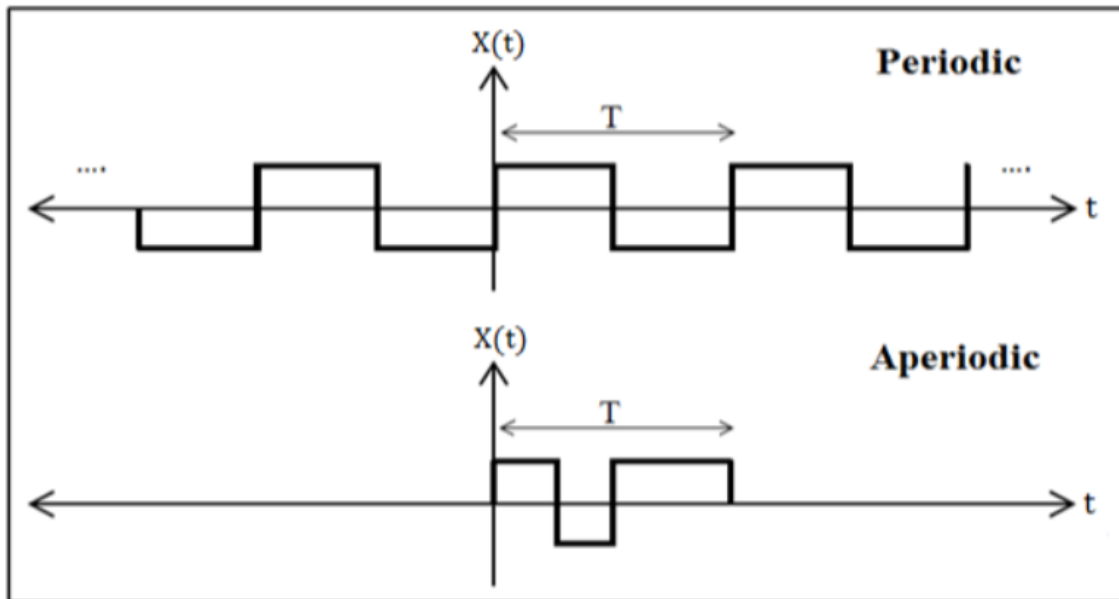

Deterministic and Random Signals:

If the value of a signal can be predicted for all time in advance without any error, it is referred to as a deterministic signal. Conversely, signals whose values cannot be predicted with complete accuracy for all time are known as random signals. Deterministic signals can generally be expressed in a mathematical, or graphical, form. Unlike deterministic signals, random signals cannot be modeled precisely.

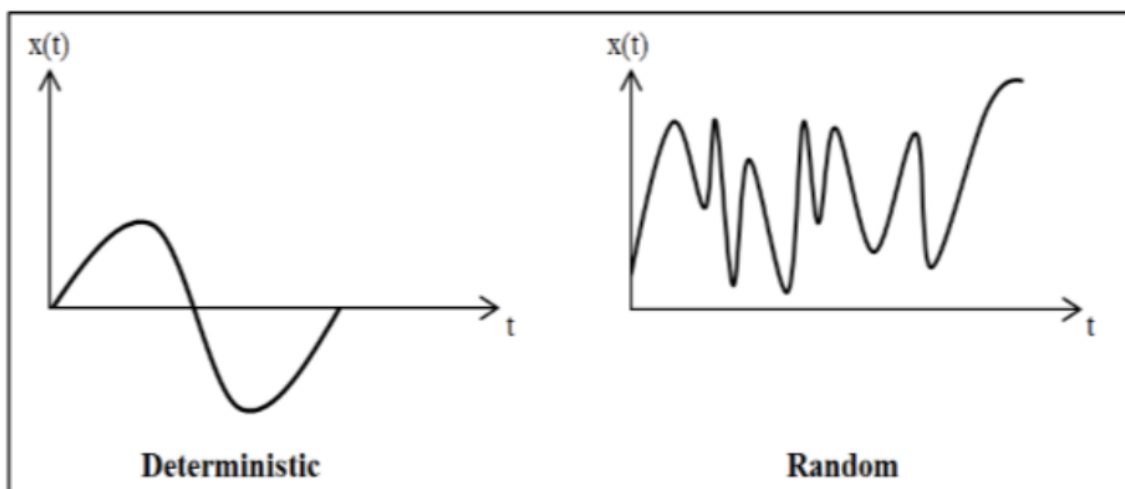



Even and Odd Signals:

A continuous-time signal $X_e(t)$ is said to be an even signal if:

$$X_e(t) = X_e(-t)$$

Conversely, a continuous-time signal $X_o(t)$ is said to be an odd signal if

$$X_o(t) = -X_o(-t)$$

From these equations, the even signal implies that an even signal is symmetric about the vertical axis ($t = 0$). Likewise, the odd signal implies that an odd signal is non-symmetric about the vertical axis ($t = 0$). In addition, there are signals that do not exhibit any symmetry about the vertical axis. Such signals are classified in the “neither odd nor even” category.

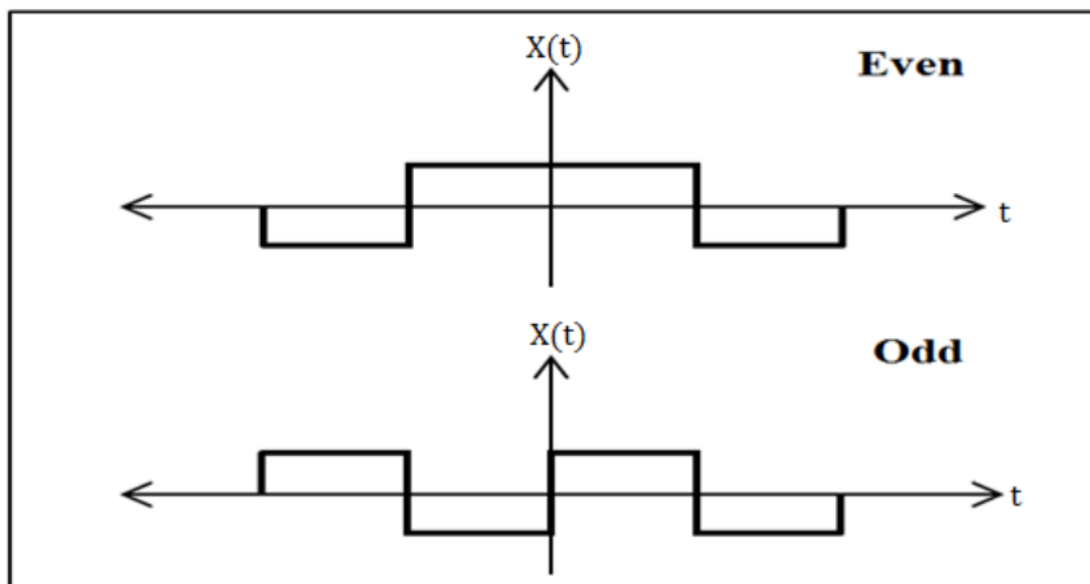



Energy and power signals

An electrical signal can be represented as a voltage $v(t)$ or current $i(t)$ with instantaneous power $P(t)$ across a resistor R defined by:

$$P(t) = \frac{v^2(t)}{R} \quad \text{or} \quad P(t) = i^2(t)R$$

In communication systems, power is often normalized by assuming R to be 1Ω , although R may be another value in the actual circuit.

$$P(t) = x^2(t)$$

Where $x(t)$ is either a voltage or a current signal. The energy dissipated during the time interval $(-T/2, T/2)$ by a real signal with instantaneous power can then be written as:

$$E_g = \int_{-T/2}^{T/2} x^2(t) dt$$

And the average power dissipated by the signal during the interval is:

$$P_{av} = \frac{E_g}{T} = \frac{1}{T} \int_{-T/2}^{T/2} x^2(t) dt$$

We classify $x(t)$ as an Energy signal if, and only if, it has nonzero but finite energy ($0 < E_g < \infty$) for all time, where



Al-Mustaqbal University
Department of Medical Instrumentation Techniques Engineering
Class: Third
Subject: Medical Communication Systems
Lecturer: Prof. Dr. Bayan Mahdi Sabbar & Dr. Mayasah Razzaq Abd-Ali
Lecture:2

$$E_g = \int_{-\infty}^{\infty} |x(t)|^2 dt$$

A signal is defined as a Power signal if, and only if, it has finite but nonzero power ($0 < P_{av} < \infty$) for all time, where

$$P_{av} = \lim_{T \rightarrow \infty} \frac{1}{T} \int_{-T/2}^{T/2} |x(t)|^2 dt$$

The energy and power classifications are mutually exclusive. An energy signal has finite energy but zero average power, whereas a power signal has finite average power but infinite energy. Some signals are neither power nor energy signals.

Example1: Classify the following Signals:

a. $x(t) = 2\cos(3t)$

b. $x(t) = \begin{cases} 1 & 0 \leq t \leq 0 \\ 0 & \text{otherwise} \end{cases}$

Solution:

a. $x(t) = 2\cos(3t)$

$$T = \frac{2\pi}{\omega} = \frac{2\pi}{3}$$

Deterministic

Even

Periodic

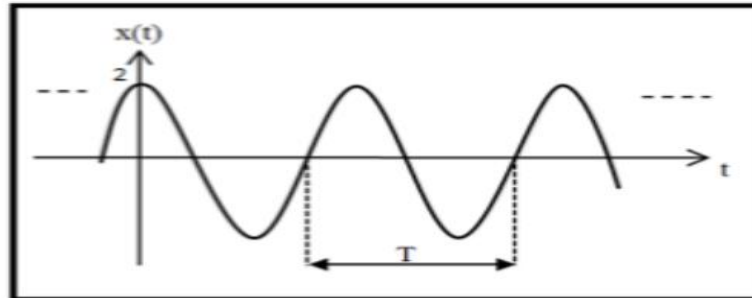

Test Power:

$$P_{av} = \frac{1}{T} \int_{-T/2}^{T/2} |x(t)|^2 dt = \frac{1}{T} \int_0^T |x(t)|^2 dt$$

$$P_{av} = \frac{1}{T} \int_0^T 4\cos^2(3t) dt$$

$$P_{av} = \frac{4}{T} \int_0^T \frac{1}{2} (1 + \cos(6t)) dt$$

$$P_{av} = \frac{2}{T} \int_0^T (1 + \cos(6t)) dt$$

$$P_{av} = \frac{3}{\pi} \int_0^{2\pi/3} (1 + \cos(6t)) dt$$

$$P_{av} = \frac{3}{\pi} \left[\int_0^{2\pi/3} 1 dt + \int_0^{2\pi/3} \cos(6t) dt \right]$$



$$P_{av} = \frac{3}{\pi} \left[\left(\frac{2\pi}{3} - 0 \right) + \frac{1}{6} (\sin(4\pi) - \sin(0)) \right]$$

$$P_{av} = 2 \text{ watt}$$

Therefore $E_g = \infty$

The signal is power signal

Test Energy

$$E_g = \int_{-\infty}^{\infty} |x(t)|^2 dt$$

$$E_g = \int_{-\infty}^{\infty} 4 \cos^2(3t) dt$$

$$E_g = 4 \int_{-\infty}^{\infty} \frac{1}{2} (1 + \cos(6t)) dt$$

$$E_g = 2 \left[\int_{-\infty}^{\infty} 1 dt + \int_{-\infty}^{\infty} \cos(6t) dt \right]$$

$$E_g = \infty$$

$$b. x(t) = \begin{cases} 1 & 0 \leq t \leq 0 \\ 0 & \text{otherwise} \end{cases}$$

Deterministic

Aperiodic

Neither odd nor even

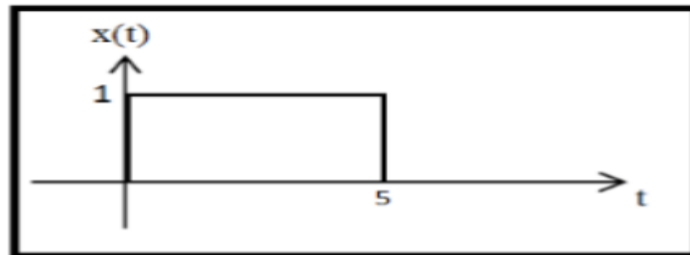

Test Energy

$$E_g = \int_{-\infty}^{\infty} |x(t)|^2 dt$$

$$E_g = \int_0^5 |1|^2 dt$$

$$E_g = \int_0^5 1 dt$$

$$E_g = 5 - 0 = 5 \text{ jouls}$$

Therefore $P_{av} = 0$

The signal is energy signal

Test Power

$$P_{av} = \lim_{T \rightarrow \infty} \frac{1}{T} \int_{-T/2}^{T/2} |x(t)|^2 dt$$

$$P_{av} = \lim_{T \rightarrow \infty} \frac{1}{T} \int_0^5 |1|^2 dt$$



$$P_{av} = \frac{1}{\infty} [5] = 0$$

Exercise : A continuous-time signal $x(t)$ is shown in Figure below. Classify this signal:

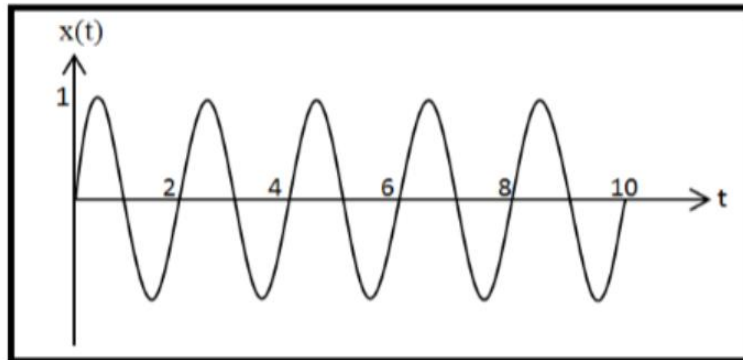

1.3 Signal Operations

In this section, we discuss three useful signal operations: inversion, shifting and scaling.

❖ **Time Inversion:** is simply flipping the signal about the y-axis

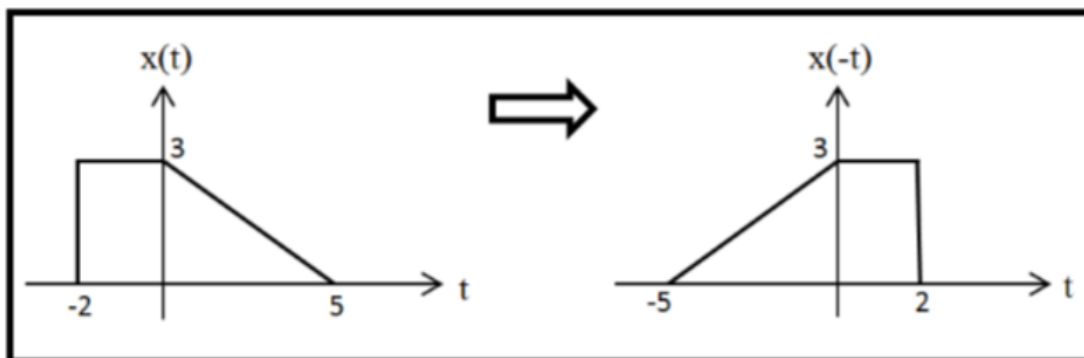

❖ **Time Shifting:** is simply shifting the signal in time. When we add a constant to the time, we obtain the advanced signal, & when we decrease the time, we get the delayed signal

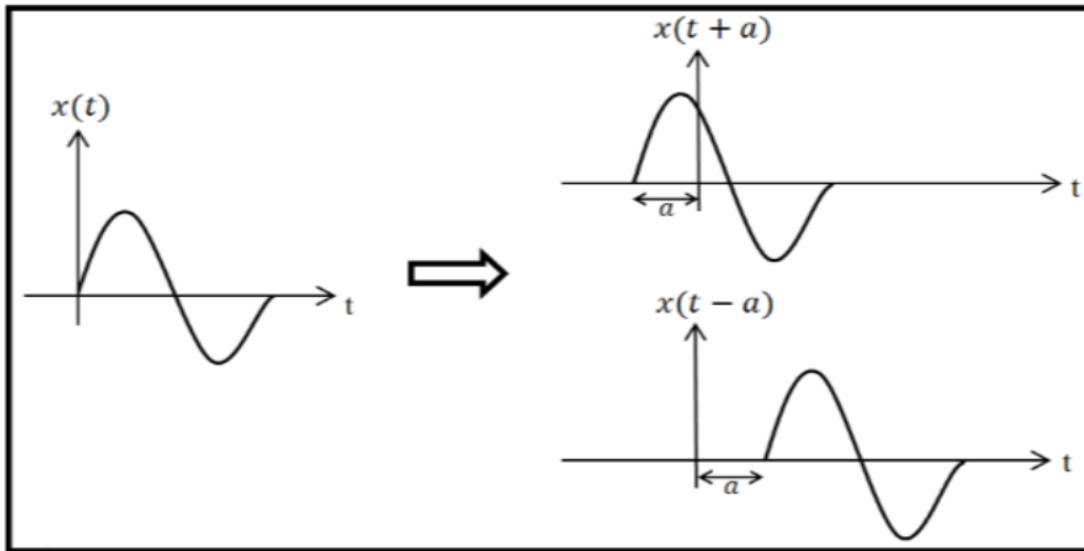

❖ Time Scaling: is defined as the process of compression or expansion the time of a signal

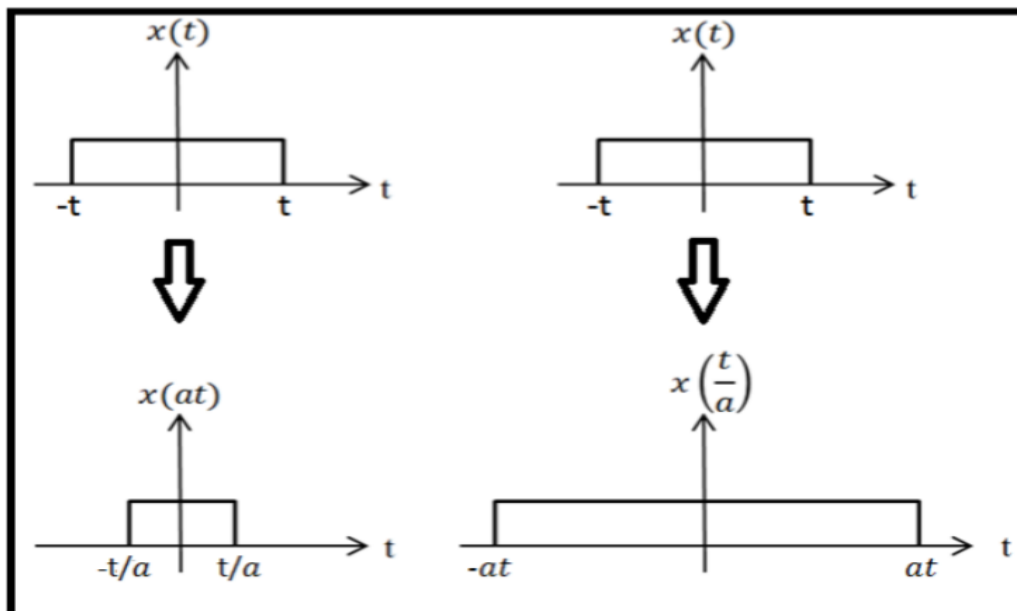

- If $a > 1$, then we have time-compression.
- If $a < 1$, then we have time-expansion.



Example 3: For the signal shown in the figure below, sketch $g\left(-1 - \frac{t}{2}\right)$.

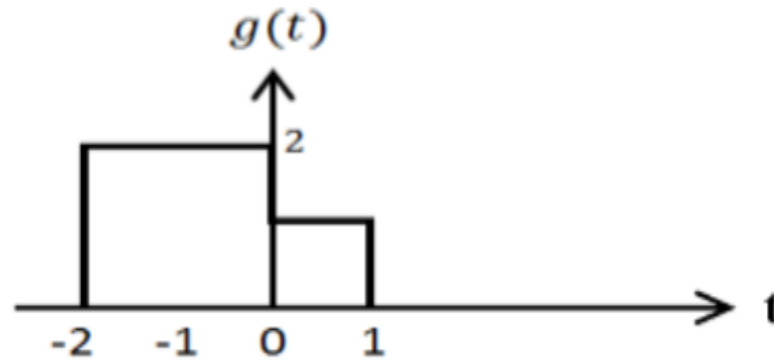

Solution:

$$g\left(-1 - \frac{t}{2}\right) = g\left(-\frac{t}{2} - 1\right) = g\left(-\frac{1}{2}(t + 2)\right)$$

Time-inverse

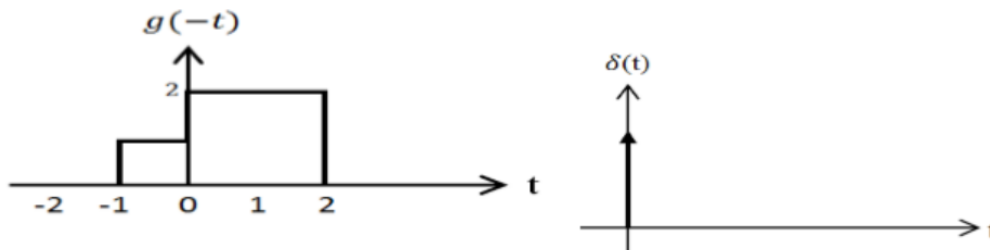

Time-scaling by $\frac{1}{2}$

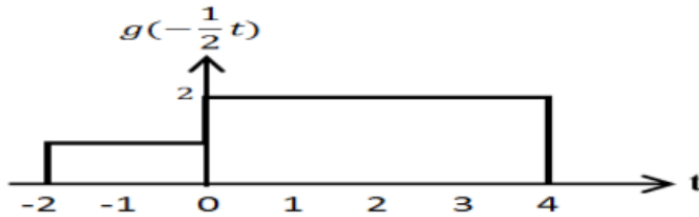

Shifting to the left by 2

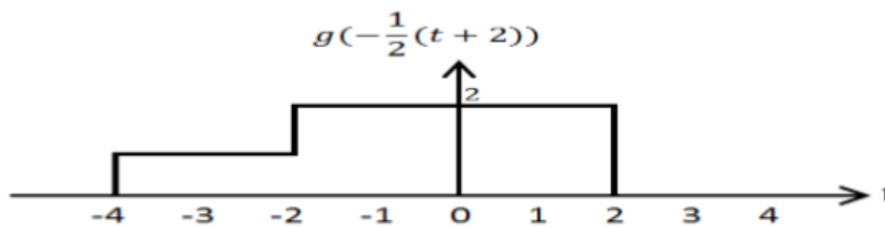

1.4 Basic Continuous-Time Signals

- Unit Step Function:

$$u(t) = \begin{cases} 1 & t \geq 0 \\ 0 & t < 0 \end{cases}$$

- Unit Impulse Function:

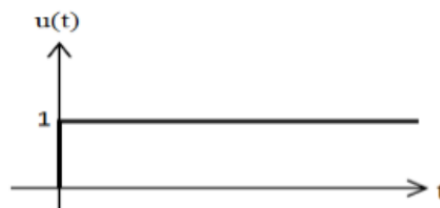

$$\delta(t) = \begin{cases} 0 & t \neq 0 \\ \infty & t = 0 \end{cases}$$



Some properties of the impulse function:

$\int_{-\infty}^{\infty} \delta(t) dt = 1$
$\int_a^b \delta(t) dt = 1 \quad , \quad a < 0 < b$
$\int_a^b \delta(t - t_0) dt = 1 \quad , \quad a < t_0 < b$
Symmetry: $\delta(t) = \delta(-t)$
Time-scaling: $\delta(at) = \frac{1}{ a } \delta(t)$
Multiplication of a function by an impulse function: <ul style="list-style-type: none">• $f(t) \delta(t) = f(0) \delta(t)$• $f(t) \delta(t - t_0) = f(t_0) \delta(t - t_0)$



Example: Evaluate the following integrals.

- $\int_{-\infty}^{\infty} \delta(t - 2)e^{-t} dt$
- $\int_1^5 \delta(t)\cos(t)dt$
- $\int_{-10}^{10} \delta(t + 2)\cos(\pi t)dt$
- $\int_{-\infty}^{\infty} [\delta(t) + u(t) - u(t - 2)]dt$
- $\int_{-\infty}^{\infty} tu(2 - t)u(t)dt$

Solution:

$$a) \int_{-\infty}^{\infty} \delta(t - 2) e^{-t} dt = \int_{-\infty}^{\infty} \delta(t - 2) e^{-2} dt = e^{-2} = 0.1353$$

$$b) \int_1^5 \delta(t) \cos(t) dt = 0$$

$$c) \int_{-10}^{10} \delta(t + 2) \cos(\pi t) dt = \int_{-10}^{10} \delta(t + 2) \cos(-2\pi) dt = 1$$



$$\begin{aligned}
 (d) \quad & \int_{-\infty}^{\infty} [\delta(t) + u(t) - u(t - 2)] dt \\
 &= \int_{-\infty}^{\infty} \delta(t) dt + \int_{-\infty}^{\infty} [u(t) - u(t - 2)] dt \\
 &= \int_{-\infty}^{\infty} \delta(t) dt + \int_0^2 1 dt \\
 &= 1 + 2 = 3
 \end{aligned}$$

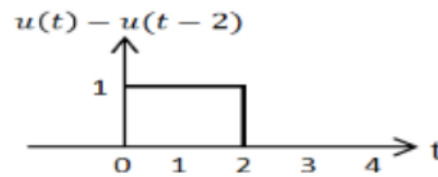
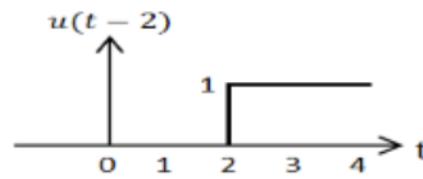
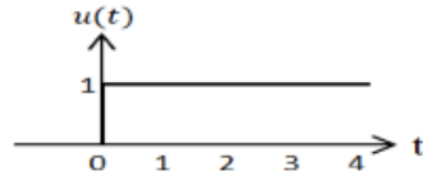

$$\begin{aligned}
 (e) \quad & \int_{-\infty}^{\infty} t u(2-t)u(t) dt \\
 &= \int_0^2 t dt = \frac{1}{2}[4 - 0] \\
 &= 2
 \end{aligned}$$

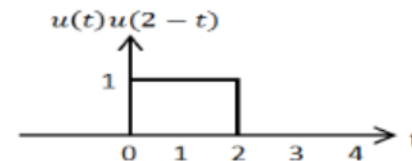
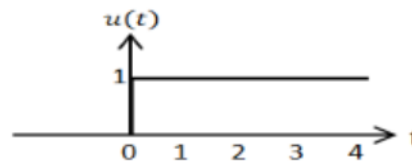
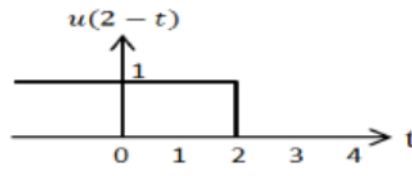

Assignment:

Classify the following signals

- a. $g(t) = e^{-2|t|}$
- b. $g(t) = e^{-2|t|}$