

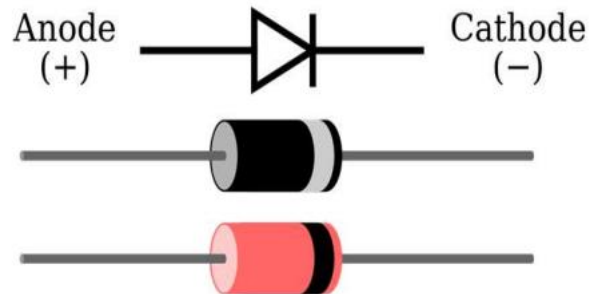

Diode Characteristics



A- Rational

We will clarify the concept of load-line analysis general and equivalent circuits to analyze series, parallel, and series-parallel diode networks.

B- Central Idea

1. definition of the load-line analysis

C. Chapter objectives

After studying the Diode Applications, the student will be able to: -

1. Understand the concept of load-line analysis and how it is applied to diode networks.
2. Become familiar with the use of equivalent circuits to analyze series, and series-parallel diode networks.

LOAD-LINE ANALYSIS

The circuit of Fig. 2.1 is the simplest of diode configurations. It will be used to describe the analysis of a diode circuit using its actual characteristics. In the next section we will replace the characteristics by an approximate model for the diode and compare solutions. Solving the circuit of Fig. 2.1 is all about

finding the current and voltage levels that will satisfy both the characteristics of the diode and the chosen network parameters at the same time. In Fig. 2.2 the diode characteristics are placed on the same set of axes as a straight line defined by the parameters of the network. The straight line is called a load line because the intersection on the vertical axis is defined by the applied load R . The analysis to follow is therefore called load-line analysis. The intersection of the two curves will define the solution for the network and define the current and voltage levels for the network.

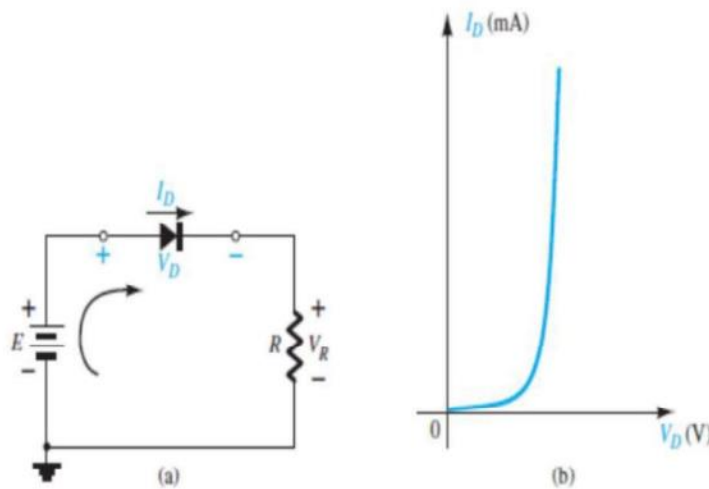

FIG. 2.1
Series diode configuration: (a) circuit; (b) characteristics.

$$+E - V_D - V_R = 0$$

$V_D = E \Big|_{I_D=0 \text{ A}}$

$E = V_D + I_D R$

$I_D = \frac{E}{R} \Big|_{V_D=0 \text{ V}}$

EXAMPLE 1: For the series diode configuration of Fig. 2.3a , employing the diode characteristics of Fig. 2.3b , determine: a. V_{DQ} and I_{DQ} . b. V_R .

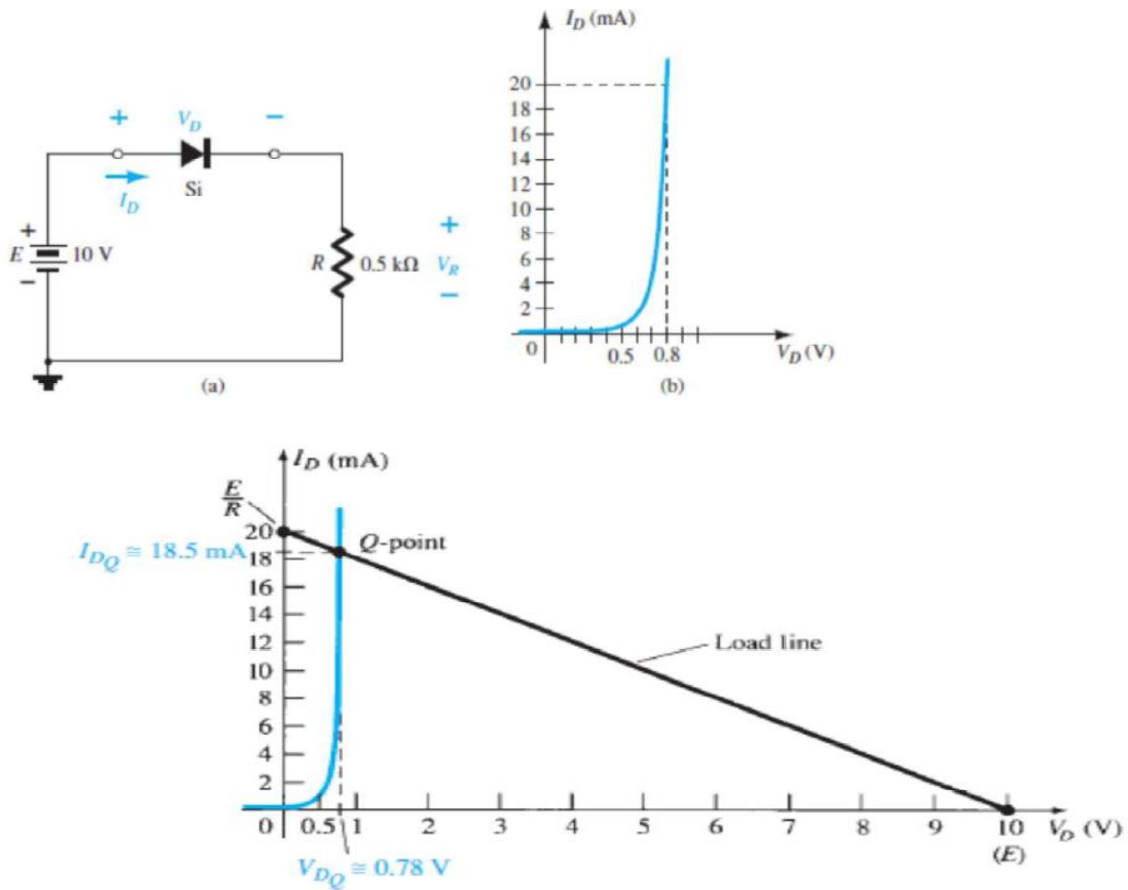

FIG. 2.4
Solution to Example 2.1.

Using the Q -point values, the dc resistance for Example 2.1 is

$$R_D = \frac{V_{DQ}}{I_{DQ}} = \frac{0.78 \text{ V}}{18.5 \text{ mA}} = 42.16 \Omega$$

An equivalent network (for these operating conditions only) can then be drawn as shown in Fig. 2.5.

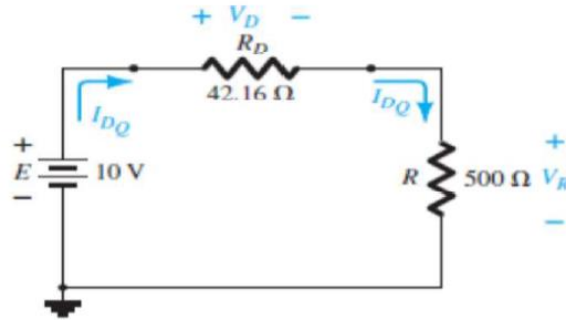

FIG. 2.5
Network equivalent to Fig. 2.4.

The current

$$I_D = \frac{E}{R_D + R} = \frac{10 \text{ V}}{42.16 \Omega + 500 \Omega} = \frac{10 \text{ V}}{542.16 \Omega} \cong 18.5 \text{ mA}$$

and

$$V_R = \frac{RE}{R_D + R} = \frac{(500 \Omega)(10 \text{ V})}{42.16 \Omega + 500 \Omega} = 9.22 \text{ V}$$

SERIES DIODE CONFIGURATIONS

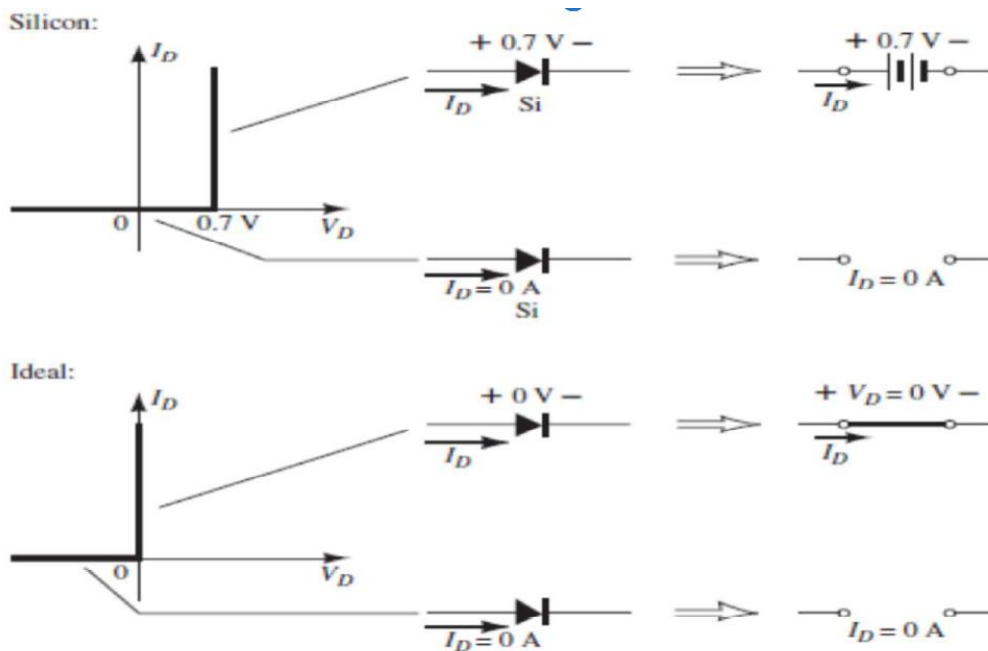

In Fig. 2.10 the diode of Fig. 2.7 has been reversed. Mentally replacing the diode with a resistive element as shown in Fig. 2.11 will reveal that the resulting current direction does not match the arrow in the diode symbol. The diode is in the state, resulting in the equivalent circuit of Fig. 2.12 . Due to the open circuit, the diode current is 0 A and the voltage across the resistor R is the following:

$$V_R = I_R R = I_D R = (0 \text{ A})R = 0 \text{ V}$$

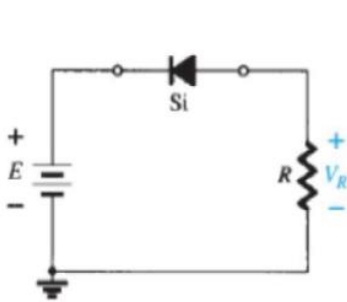

FIG. 2.10
Reversing the diode of Fig. 2.8.

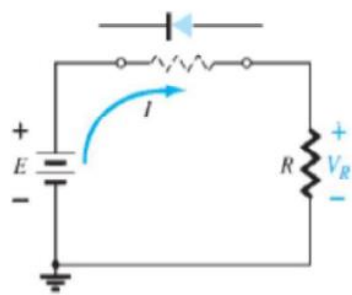

FIG. 2.11
Determining the state of the diode of Fig. 2.10.

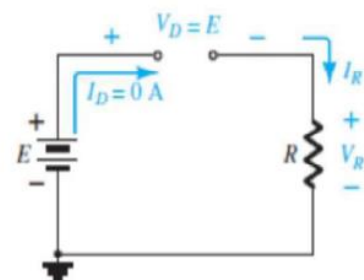

FIG. 2.12
Substituting the equivalent model for the "off" diode of Fig. 2.10.

EXAMPLE 4 For the series diode configuration of Fig. 2.13 determine V_D , V_R , and I_D

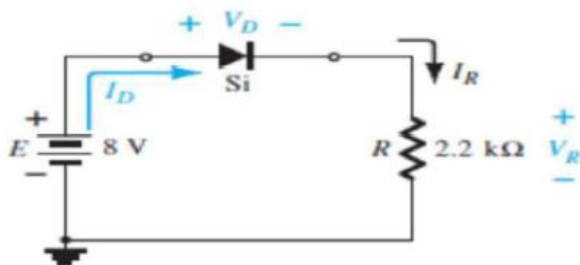

FIG. 2.13
Circuit for Example 2.4.

Solution: Since the applied voltage establishes a current in the clockwise direction to match the arrow of the symbol and the diode is in the “on” state,

$$V_D = 0.7 \text{ V}$$

$$V_R = E - V_D = 8 \text{ V} - 0.7 \text{ V} = 7.3 \text{ V}$$

$$I_D = I_R = \frac{V_R}{R} = \frac{7.3 \text{ V}}{2.2 \text{ k}\Omega} \cong 3.32 \text{ mA}$$

EXAMPLE 2.6 For the series diode configuration of Fig. 2.16 determine V_D , V_R , and I_D

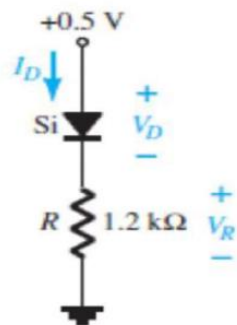

FIG. 2.16
Series diode circuit for Example 2.6.

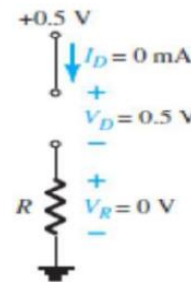

FIG. 2.18
Determining I_D , V_R , and V_D for the circuit of Fig. 2.16.

Solution: Although the “pressure” establishes a current with the same direction as the arrow symbol, the level of applied voltage is insufficient to turn the silicon diode “on.” The point of operation on the characteristics is shown in Fig. 2.17, establishing the open-circuit equivalent as the appropriate approximation, as shown in Fig. 2.18. The resulting voltage and current levels are therefore the following:

$$I_D = 0 \text{ A}$$

$$V_R = I_R R = I_D R = (0 \text{ A}) 1.2 \text{ k}\Omega = 0 \text{ V}$$

and

$$V_D = E = 0.5 \text{ V}$$

EXAMPLE 2.8 Determine I_D , V_{D2} , and V_o for the circuit of Fig. 2.21 ..

Solution: Removing the diodes and determining the direction of the resulting current I result in the circuit of Fig. 2.22 . There is a match in current direction for one silicon diode but not for the other silicon diode. The combination of a short circuit in series with an open circuit always results in an open circuit and $I_D = 0$ A, as shown in Fig. 2.23 .

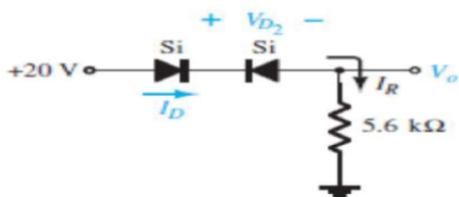

FIG. 2.21
Circuit for Example 2.8.

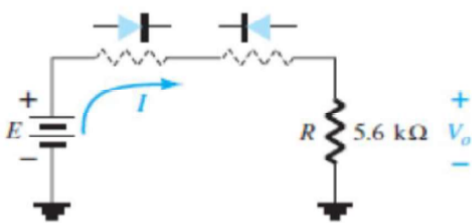

FIG. 2.22
Determining the state of the diodes of Fig. 2.21.

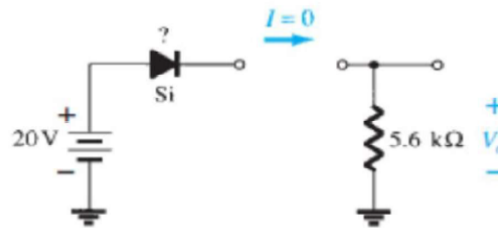

FIG. 2.23
Substituting the equivalent state for the open diode.

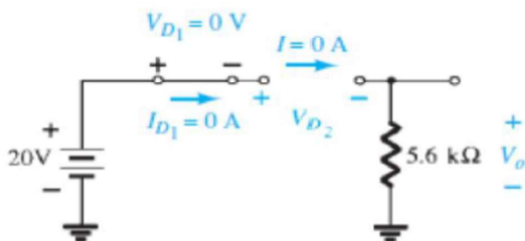

FIG. 2.24
Determining the unknown quantities for the circuit of Example 2.8.



The question remains as to what to substitute for the silicon diode. For the analysis to follow in this and succeeding chapters, simply recall for the actual practical diode that when $I_D = 0$ A, $V_D = 0$ V (and vice versa), as described for the no-bias situation in Chapter 1. The conditions described by $I_D = 0$ A and $V_{D1} = 0$ V are indicated in Fig. 2.24. We have

$$V_o = I_R R = I_D R = (0 \text{ A})R = 0 \text{ V}$$

and
$$V_{D2} = V_{\text{open circuit}} = E = 20 \text{ V}$$

Applying Kirchhoff's voltage law in a clockwise direction gives

$$E - V_{D1} - V_{D2} - V_o = 0$$

and
$$V_{D2} = E - V_{D1} - V_o = 20 \text{ V} - 0 - 0 = 20 \text{ V}$$

with
$$V_o = 0 \text{ V}$$

PARALLEL AND SERIES PARALLEL CONFIGURATION

The methods applied in Section 2.3 can be extended to the analysis of parallel and series parallel configurations. For each area of application, simply match the sequential series of steps applied to series diode configurations.

EXAMPLE 10 Determine V_o , I_1 , I_{D1} , and I_{D2} for the parallel diode configuration of Fig. 2.28

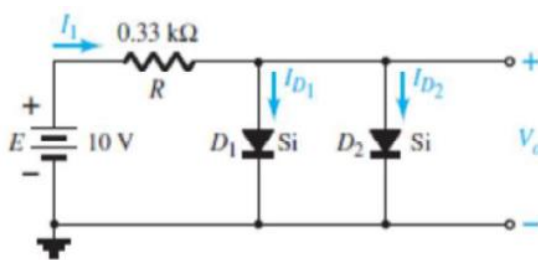

FIG. 2.28
Network for Example 2.10.

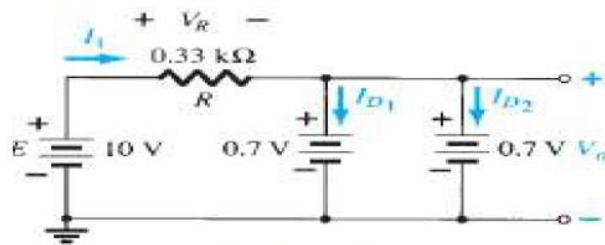

FIG. 2.29
Determining the unknown quantities for the network of Example 2.10.

Solution: For the applied voltage the of the source acts to establish a current through each diode in the same direction as shown in Fig. 2.29 . Since the

resulting current direction matches that of the arrow in each diode symbol and the applied voltage is greater than 0.7 V, both diodes are in the state. The voltage across parallel elements is always the same

$$V_o = 0.7 \text{ V}$$

The current is

$$I_1 = \frac{V_R}{R} = \frac{E - V_D}{R} = \frac{10 \text{ V} - 0.7 \text{ V}}{0.33 \text{ k}\Omega} = 28.18 \text{ mA}$$

Assuming diodes of similar characteristics, we have

$$I_{D1} = I_{D2} = \frac{I_1}{2} = \frac{28.18 \text{ mA}}{2} = 14.09 \text{ mA}$$

EXAMPLE 2.13 Determine the currents I_1 , I_2 , and I_{D2} for the network of Fig. 2.37

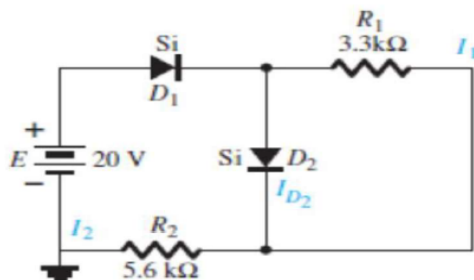

FIG. 2.37
Network for Example 2.13.

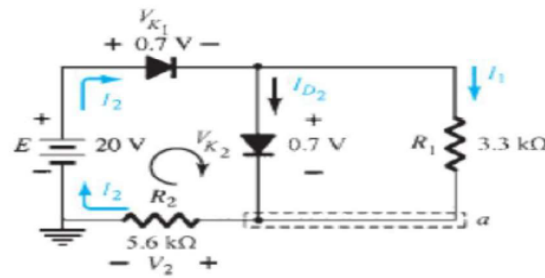

FIG. 2.38
Determining the unknown quantities for Example 2.13.

Solution: The applied voltage (pressure) is such as to turn both diodes on, as indicated by the resulting current directions in the network of Fig. 2.38. Note the use of the abbreviated notation for “on” diodes and that the solution is obtained through an application of techniques applied to dc series–parallel networks. We have



$$I_1 = \frac{V_{K_2}}{R_1} = \frac{0.7 \text{ V}}{3.3 \text{ k}\Omega} = 0.212 \text{ mA}$$

Applying Kirchhoff's voltage law around the indicated loop in the clockwise direction yields

$$-V_2 + E - V_{K_1} - V_{K_2} = 0$$

and $V_2 = E - V_{K_1} - V_{K_2} = 20 \text{ V} - 0.7 \text{ V} - 0.7 \text{ V} = 18.6 \text{ V}$

with $I_2 = \frac{V_2}{R_2} = \frac{18.6 \text{ V}}{5.6 \text{ k}\Omega} = 3.32 \text{ mA}$

At the bottom node a ,

$$I_{D_2} + I_1 = I_2$$

and $I_{D_2} = I_2 - I_1 = 3.32 \text{ mA} - 0.212 \text{ mA} \cong 3.11 \text{ mA}$