



Class: 4nd Stage

Subject: Renewable Energy
Asst.Lecturer: Mohamed Sabah
E-mail: mohamed.sabah@uomus.edu.iq



Experiments No. (2)

Effect of PV Panel Temperature on Output Power Generation

1 -Introduction:-

Energy produced by the sun is called solar energy. It is produced during nuclear reactions that take place throughout the volume of the sun. The energy travels to Earth in the form of light. Photovoltaic (PV) cells, or solar cells, change the light energy to electrical energy that can be used to power calculators, cars or even satellites. A photovoltaic cell is usually made of a semiconducting material such as silicon. When light strikes the cell, it provides enough energy to move electrons through the cell producing an electric current. A single photovoltaic cell is approximately the size of a fingernail and puts out a very small current when struck by the light. Objects requiring higher currents to operate can be powered by wiring large numbers of photovoltaic cells together. Items powered by solar energy are said to be using solar power. Streetlights that must operate in the dark store the energy in a battery while the sun is shining and then use the energy at night. Scientists working in remote places rely on solar power to operate their computers and equipment.



Class: 4nd Stage

Subject: Renewable Energy
Asst.Lecturer: Mohamed Sabah
E-mail: mohamed.sabah@uomus.edu.iq



Figure (1) photovoltaic cell

2 -Purpose of the experiment:-

In this experiment, you will measure the current and voltage produced by a photovoltaic cell when exposed to sunlight with effect of rising of PV panel temperature.

3 -Theory:-

The power output of the panel is calculated by using the relationship

$$P = VI$$

Power = voltage × current



Class: 4nd Stage

Subject: Renewable Energy
Asst.Lecturer: Mohamed Sabah
E-mail: mohamed.sabah@uomus.edu.iq



You will also calculate the efficiency of the photovoltaic cell when converting the energy from the sun into electrical energy by using the relationship.

4 - Apparatus:-

4.1 Objective

In this experiment, you will

- Use a Current Probe to measure current output.
- Use a Voltage Probe to measure voltage output.
- Use a Light Sensor to measure light intensity.
- Calculate power output.
- Calculate efficiency.
- Investigate the relationship between PV panel temperature and power output.

4.2 Materials:-

- 1-photovoltaic cell
- 2-wire leads with alligator clips
- 3-Current Probe
- 4-Voltage Probe
- 5-Light Sensor, ruler
- 6- One K-Type thermocouple.



Class: 4nd Stage

Subject: Renewable Energy
Asst.Lecturer: Mohamed Sabah
E-mail: mohamed.sabah@uomus.edu.iq



5 Pre lab questions:-

1. In of this experiment, the efficiency of the photovoltaic cell is determined. A cell that converts all of the light energy into electrical energy is said to be 100% efficient which in reality is not attainable. What do you predict to be the efficiency of the cell? Express your answer in percent form with 100% representing that all of the sunlight is converted to electrical energy and 0% representing that none of the sunlight is converted to electrical energy.
2. The relationship between **temperatures** of the PV panel with the power output of the cell will be investigated. Do you think this factor will affect the power output?

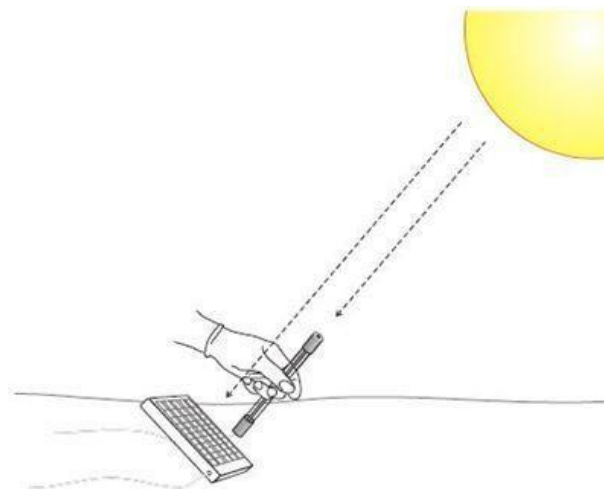

Figure (2)



Class: 4nd Stage

Subject: Renewable Energy
Asst.Lecturer: Mohamed Sabah
E-mail: mohamed.sabah@uomus.edu.iq



6 - Procedures:-

Determining Power Output Affected by PV Panel Rising Temperature.

1. Connect the Current Probe to Channel 1, the Voltage Probe into Channel 2, and the Light Sensor to Channel 3.
2. Connect together the two voltage leads (red and black) of the Voltage Probe in Parallel with PV panel.
3. Connect the series circuit shown in Figure 2. The red terminal of the Current Probe should be toward the + terminal of the photovoltaic cell. Look at the bottom of the PV cell to determine polarity. Connect the red lead of the Voltage probe to the wire coming from the + terminal of the PV cell and the black lead to the wire leading to the – terminal.
4. Tilt the PV cell toward the sun. Hold the Light Sensor at the same angle. The light intensity reading is displayed in the W/m^2 .
5. Record the date for different values of PV Panel temperature in table (B).

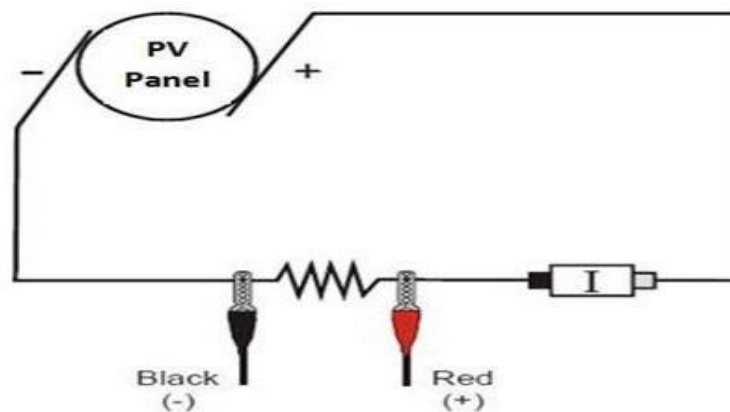

Figure (3)



Class: 4nd Stage

Subject: Renewable Energy
 Asst.Lecturer: Mohamed Sabah
 E-mail: mohamed.sabah@uomus.edu.iq



DATA

Table (B)

	PV panel Temp.(Deg.C)	Current (A)	Voltage (V)	Light Intensity (W/m ²)
Trial 1				
Trial 2				
Trial 3				
Trial 4				
Trial 5				
Trial 6				

Instructions for completing the following table can be found in the Processing the data section.

Power Output (W)	
Number of cells on panel	
Area of each cell (cm ²)	
Total area of solar cells (m ²)	
Power per square meter (W/m ²)	
Power from the sun (W/m ²)	
Panel efficiency	



Class: 4nd Stage

Subject: Renewable Energy
Asst.Lecturer: Mohamed Sabah
E-mail: mohamed.sabah@uomus.edu.iq



7 - Processing the Data:-

With using a K-Type thermo couple to measure the PV panel temperature;

1. Calculate the average current, voltage and light intensity values.
2. Calculate the power output using the equation

$$P = VI$$

Power = voltage × current

3. Examine the open PV cell and record the number of cells on the panel.
4. Determine the area of one cell in cm². Remember, the area of a rectangle is (length × width) and the area of a triangle is (½ base × height). Draw a diagram of one cell and label any measurements that will help when calculating the area.
5. Calculate the total area of the cells in m² using the equation (Number of cells on panel × Area of one cell).
6. Determine the power per square meter output of the PV cell by dividing the power output by the total area of the cell.
7. Determine the power per square meter output of the sun by in W/m².
8. Calculate the efficiency of the PV cell using the equation

$$\text{Efficiency} = \frac{\text{voltage} \times \text{current}}{\text{Irradiation} \times \text{PV panel area}}$$



Class: 4nd Stage

Subject: Renewable Energy
Asst.Lecturer: Mohamed Sabah
E-mail: mohamed.sabah@uomus.edu.iq



9. How does the efficiency of your PV cell compare to your predicted efficiency?
10. What factors may contribute to the lack of efficiency of the PV cell?
11. Calculate the power output for each of the trials using the equation

$$P = VI$$

Power = voltage × current

12. What types of conditions would contribute to an ideal location for PV cells used for electricity to heat a home?

8 Extensions:-

Plot the relationship between the PV panel temperature and the power output of a PV Panel.