



## Lecture Eight

### Sinusoidal Steady-State Analysis

#### 8.1 Introduction

In lecture 7, we learned that the forced or steady-state response of circuits to sinusoidal inputs can be obtained by using phasors. We also know that Ohm's and Kirchhoff's laws are applicable to ac circuits. In this chapter, we want to see how nodal analysis, mesh analysis, Thevenin's theorem, Norton's theorem, superposition, and source transformations are applied in analyzing ac circuits. Since these techniques were already introduced for dc circuits, our major effort here will be to illustrate with examples.

Analyzing ac circuits usually requires three steps.

#### Steps to Analyze ac Circuits:

1. Transform the circuit to the phasor or frequency domain.
2. Solve the problem using circuit techniques (nodal analysis, mesh analysis, superposition, etc.).
3. Transform the resulting phasor to the time domain.

Step 1 is not necessary if the problem is specified in the frequency domain. In step 2, the analysis is performed in the same manner as dc circuit analysis except that complex numbers are involved. Having read lecture 7, we are adept at handling step 3.

#### 8.2 Nodal Analysis

The basis of nodal analysis is Kirchhoff's current law. Since KCL is valid for phasors, we can analyze ac circuits by nodal analysis. The following examples illustrate this.

**Example 8.1:** Find  $i_x$  in the circuit of Fig. 8.1 using nodal analysis.

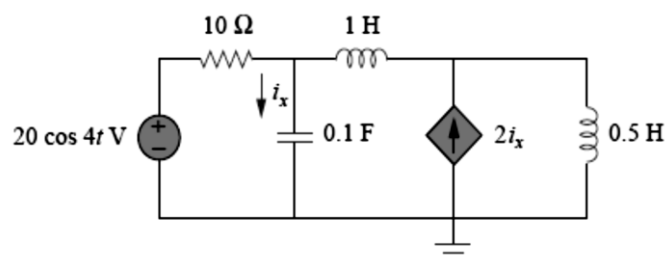

Fig. 8.1

**Solution:**

We first convert the circuit to the frequency domain:

$$20 \cos 4t \Rightarrow 20 \angle 0^\circ, \omega = 4 \text{ rad/s}$$

$$1\text{H} \Rightarrow j\omega L = j 4$$

$$0.5\text{H} \Rightarrow j\omega L = j 2$$

$$0.1\text{F} \Rightarrow \frac{1}{j\omega C} = -j2.5$$

Thus, the frequency-domain equivalent circuit is as shown in Fig. 8.2.

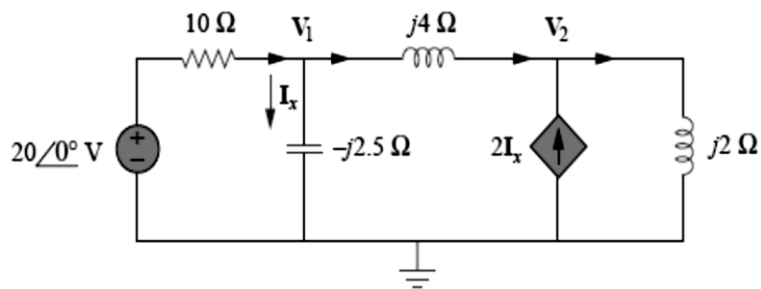

**Figure 8.2** Frequency-domain equivalent of the circuit in Fig. 8.1.

Applying KCL at node 1,

$$\frac{20 - v_1}{10} = \frac{v_1}{-j2.5} + \frac{v_1 - v_2}{j4}$$

or

$$(1 + j1.5) v_1 + j2.5 v_2 = 20 \tag{8.1.1}$$

At node 2,

$$2I_x + \frac{v_1 - v_2}{j4} = \frac{v_2}{j2}$$

But  $I_x = v_1 / -j 2.5$ . Substituting this gives

$$\frac{2v_1}{-j2.5} + \frac{v_1 - v_2}{j4} = \frac{v_2}{j2}$$

By simplifying, we get

$$11 v_1 + 15 v_2 = 0 \tag{8.1.2}$$

Eqs. (8.1.1) and (8.1.2) can be put in matrix form as

$$\begin{bmatrix} 1 + j1.5 & j2.5 \\ 11 & 15 \end{bmatrix} \begin{bmatrix} v_1 \\ v_2 \end{bmatrix} = \begin{bmatrix} 20 \\ 0 \end{bmatrix}$$

We obtain the determinants as

$$\Delta = D = \begin{vmatrix} 1 + j1.5 & j2.5 \\ 11 & 15 \end{vmatrix} = 15 - j5$$

$$\Delta_1 = D_1 = \begin{vmatrix} 20 & j2.5 \\ 0 & 15 \end{vmatrix} = 300, \quad \Delta_2 = D_2 = \begin{vmatrix} 1 + j1.5 & 20 \\ 11 & 0 \end{vmatrix} = -200$$

$$V_1 = \frac{D_1}{D} = \frac{300}{15 - j5} = 18.97 \angle 18.43^\circ \text{ V}$$

$$V_2 = \frac{D_2}{D} = \frac{-220}{15 - j5} = 13.91 \angle 198.3^\circ \text{ V}$$

The current  $I_x$  is given by

$$I_x = \frac{V_1}{-j2.5} = \frac{18.97 \angle 18.43^\circ}{2.5 \angle -90^\circ} = 7.59 \angle 108.4^\circ \text{ A}$$

Transforming this to the time domain,

$$i_x = 7.59 \cos(4t + 108.4^\circ) \text{ A}$$

**Example 8.2:** Compute  $V_1$  and  $V_2$  in the circuit of Fig. 8.3.

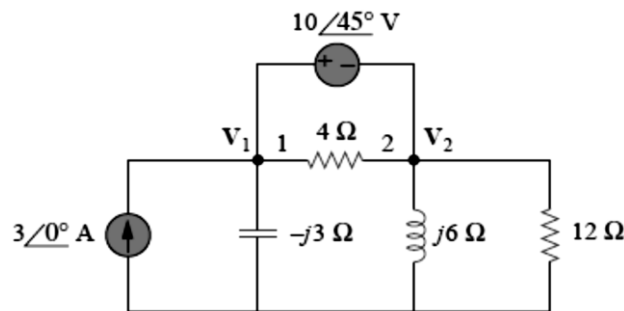

Figure 8.3

**Solution:** Nodes 1 and 2 form a super-node as shown in Fig. 8.4. Applying KCL at the super-node gives

$$3 = \frac{V_1}{-j3} + \frac{V_2}{j6} + \frac{V_2}{12}$$

or

$$36 = j4 V_1 + (1 - j2) V_2 \tag{8.2.1}$$

But a voltage source is connected between nodes 1 and 2, so that

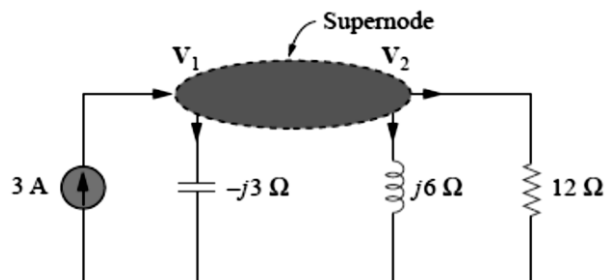

Figure 8.4 A supernode in the circuit of Fig. 8.3.

$$V_1 = V_2 + 10 \angle 45^\circ \tag{8.2.2}$$

Substituting Eq. (8.2.2) in Eq. (8.2.1) results in

$$36 - 40 \angle 135^\circ = (1 + j2) V_2 \quad \Rightarrow \quad V_2 = 31.41 \angle -87.18^\circ \text{ V}$$

From Eq. (8.2.2),

$$V_1 = V_2 + 10 \angle 45^\circ = 25.78 \angle -70.48^\circ \text{ V}$$

### 8.3 Mesh Analysis

Kirchhoff's voltage law (KVL) forms the basis of mesh analysis. The validity of KVL for ac circuits was shown in Section 7.5 and is illustrated in the following examples.

**Example 8.3:** Determine current  $I_o$  in the circuit of Fig. 8.5 using mesh analysis.

**Solution:**

Applying KVL to mesh 1, we obtain

$$(8 + j10 - j2) I_1 - (-j2) I_2 - j10 I_3 = 0 \tag{8.3.1}$$

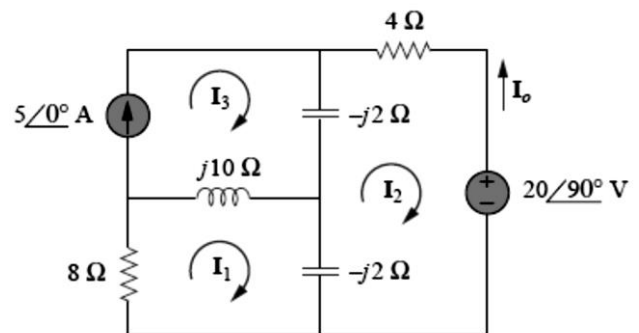

**Fig. 8.5**

For mesh 2,

$$(4 - j2 - j2) I_2 - (-j2) I_1 - (-j2) I_3 + 20 \angle 90^\circ = 0 \tag{8.3.2}$$

For mesh 3,  $I_3 = 5$ . Substituting this in Eqs. (8.3.1) and (8.3.2), we get

$$(8 + j8) I_1 + j2 I_2 = j50 \tag{8.3.3}$$

$$j2 I_1 + (4 - j4) I_2 = -j20 - j10 \tag{8.3.4}$$

Equations (8.3.3) and (8.3.4) can be put in matrix form as

$$\begin{bmatrix} 8 + j8 & j2 \\ j2 & 4 - j4 \end{bmatrix} \begin{bmatrix} I_1 \\ I_2 \end{bmatrix} = \begin{bmatrix} j50 \\ -j30 \end{bmatrix}$$

from which we obtain the determinants

$$\Delta = D = \begin{vmatrix} 8 + j8 & j2 \\ j2 & 4 - j4 \end{vmatrix} = 32(1 + j)(1 - j) + 4 = 68$$

$$\Delta_2 = D_2 = \begin{vmatrix} 8 + j8 & j5 \\ j2 & -j30 \end{vmatrix} = 340 - j240 = 416.17 \angle -35.22^\circ,$$

$$I_2 = \frac{D_2}{D} = \frac{416.17 \angle -35.22^\circ}{68} = 6.12 \angle -35.22^\circ \text{ A}$$

The desired current is

$$I_o = -I_2 = 6.12 \angle 144.78^\circ \text{ A}$$

**Example 8.4:** Solve for  $V_o$  in the circuit in Fig. 8.6 using mesh analysis.

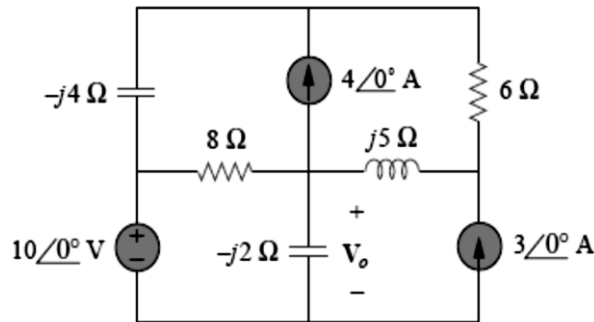

**Fig. 8.6**

**Solution:**

As shown in Fig. 8.7, meshes 3 and 4 form a supermesh due to the current source between the meshes. For mesh 1, KVL gives

$$-10 + (8 - j2) I_1 - (-j2) I_2 - 8 I_3 = 0$$

or

$$(8 - j2) I_1 + j2 I_2 - 8 I_3 = 10 \tag{8.4.1}$$

For mesh 2,

$$I_2 = -3 \tag{8.4.2}$$

For the supermesh,

$$(8 - j4) I_3 - 8 I_1 + (6 + j5) I_4 - j5 I_2 = 0 \tag{8.4.3}$$

Due to the current source between meshes 3 and 4, at node A,

$$I_4 = I_3 + 4 \tag{8.4.4}$$

Combining Eqs. (8.4.1) and (8.4.2),

$$(8 - j2) I_1 - 8 I_3 = 10 + j6 \tag{8.4.5}$$

Combining Eqs. (8.4.2) to (8.4.4),

$$-8 I_1 + (14 + j) I_3 = -24 - j35 \tag{8.4.6}$$

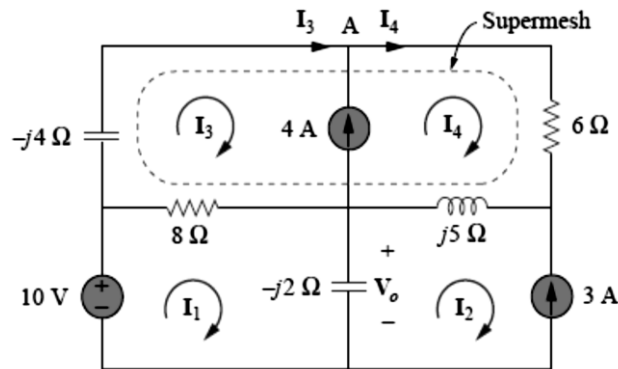

Figure 8.7 Analysis of the circuit in Fig. 8.6.

From Eqs. (8.4.5) and (8.4.6), we obtain the matrix equation

$$\begin{bmatrix} 8 - j2 & -8 \\ -8 & 14 + j \end{bmatrix} \begin{bmatrix} I_1 \\ I_3 \end{bmatrix} = \begin{bmatrix} 10 + j6 \\ -24 - j35 \end{bmatrix}$$

from which we obtain the determinants

$$\Delta = D = \begin{vmatrix} 8 - j2 & -8 \\ -8 & 14 + j \end{vmatrix} = 112 + j8 - j28 + 2 - 64 = 50 - j20$$

$$\begin{aligned} \Delta_1 = D_1 &= \begin{vmatrix} 10 + j6 & -8 \\ -24 - j35 & 14 + j \end{vmatrix} = 140 + j10 + j84 - 6 - 192 - j280 \\ &= -58 - j186 \end{aligned}$$

Current  $I_1$  is obtained as

$$I_1 = \frac{D_1}{D} = \frac{-58 - j186}{50 - j20} = 3.618 \angle 274.5^\circ \text{ A}$$

We obtain the following determinants

The required voltage  $V_o$  is

$$\begin{aligned} V_o &= -j2 (I_1 - I_2) = -j2 (3.618 \angle 274.5^\circ + 3) \\ &= -7.2134 - j6.568 = 9.756 \angle 222.32^\circ \text{ V} \end{aligned}$$

## 8.4 Superposition Theorem

Since ac circuits are linear, the superposition theorem applies to ac circuits the same way it applies to dc circuits. The theorem becomes important if the circuit has sources operating at different frequencies. In this case, since the impedances depend on frequency, we must have a different frequency-domain circuit for each frequency. The total response must be obtained by adding the individual responses in the time domain. It is incorrect to try to add the responses in the phasor or frequency domain. Why? Because the exponential factor  $e^{j\omega t}$  is implicit in sinusoidal analysis, and that factor would change for every angular frequency  $\omega$ . It would

therefore not make sense to add responses at different frequencies in the phasor domain. Thus, when a circuit has sources operating at different frequencies, one must add the responses due to the individual frequencies in the time domain.

**Example 8.5:** Use the superposition theorem to find  $I_o$  in the circuit in Fig. 8.5.

**Solution:**

Let

$$I_o = I'o + I''o \tag{8.5.1}$$

where  $I'o$  and  $I''o$  are due to the voltage and current sources, respectively. To find  $I'o$ , consider the circuit in Fig. 8.8(a). If we let  $Z$  be the parallel combination of  $-j2$  and  $8 + j10$ , then

$$Z = \frac{-j2(8 + j10)}{-2j + 8 + j10} = 0.25 - j2.25$$

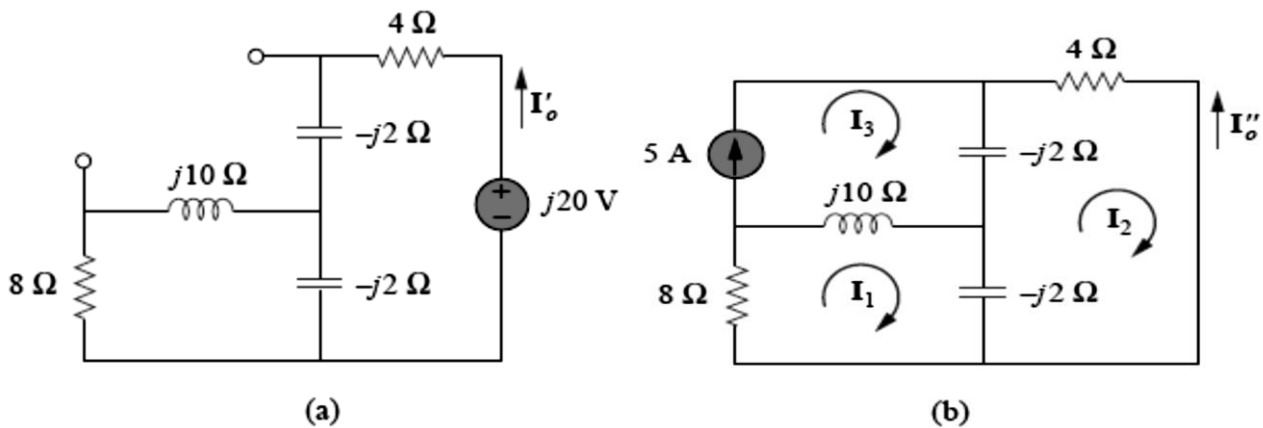

Figure 8.8 Solution of Example 8.5.

and current  $I'o$  is

$$I'o = \frac{j20}{4 - j2 + Z} = \frac{j20}{4.25 - j4.25}$$

or  $I'o = -2.353 + j2.353 \tag{8.5.2}$

To get  $I''o$ , consider the circuit in Fig. 8.8(b). For mesh 1,

$$(8 + j8) I_1 - j10 I_3 + j2 I_2 = 0 \tag{8.5.3}$$

For mesh 2,

$$(4 - j4) I_2 + j2 I_1 + j2 I_3 = 0 \tag{8.5.4}$$

For mesh 3,



$$\mathbf{I3} = 5 \tag{8.5.5}$$

From Eqs. (8.5.4) and (8.5.5),

$$(4 - j4) \mathbf{I2} + j2 \mathbf{I1} + j10 = 0$$

Expressing  $\mathbf{I1}$  in terms of  $\mathbf{I2}$  gives

$$\mathbf{I1} = (2 + j2) \mathbf{I2} - 5 \tag{8.5.6}$$

Substituting Eqs. (8.5.5) and (8.5.6) into Eq. (8.5.3), we get

$$(8 + j8)[(2 + j2) \mathbf{I2} - 5] - j50 + j2 \mathbf{I2} = 0$$

or

$$\mathbf{I2} = \frac{90 - j40}{34} = 2.647 - j1.176$$

Current  $\mathbf{I''o}$  is obtained as

$$\mathbf{I''o} = -\mathbf{I2} = -2.647 + j1.176 \tag{8.5.7}$$

From Eqs. (8.5.2) and (8.5.7), we write

$$\mathbf{Io} = \mathbf{I'o} + \mathbf{I''o} = -5 + j3.529 = 6.12 \angle 144.78^\circ \text{ A}$$

which agrees with what we got in Example 10.3. It should be noted that applying the superposition theorem is not the best way to solve this problem. It seems that we have made the problem twice as hard as the original one by using superposition. However, in Example 10.6, superposition is clearly the easiest approach.

**Example 8.6:** Find  $\mathbf{vo}$  in the circuit in Fig. 8.9 using the superposition theorem.

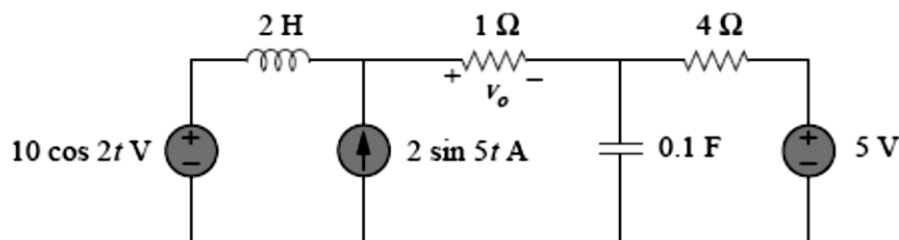

**Figure 8.9** For Example 8.6.

**Solution:**

Since the circuit operates at three different frequencies ( $\omega = 0$  for the dc voltage source), one way to obtain a solution is to use superposition, which breaks the problem into single-frequency problems. So we let

$$\mathbf{vo} = \mathbf{v1} + \mathbf{v2} + \mathbf{v3} \tag{8.6.1}$$



where  $v_1$  is due to the 5-V dc voltage source,  $v_2$  is due to the  $10 \cos 2t$  V voltage source, and  $v_3$  is due to the  $2 \sin 5t$  A current source.

To find  $v_1$ , we set to zero all sources except the 5-V dc source. We recall that at steady state, a capacitor is an open circuit to dc while an inductor is a short circuit to dc. There is an alternative way of looking at this. Since  $\omega = 0$ ,  $j\omega L = 0$ ,  $1/j\omega C = \infty$ . Either way, the equivalent circuit is as shown in Fig. 8.10(a). By voltage division,

$$- v_1 = \frac{1}{1+4} (5) = 1V \tag{8.6.2}$$

To find  $v_2$ , we set to zero both the 5-V source and the  $2 \sin 5t$  current source and transform the circuit to the frequency domain.

$$10 \cos 2t \Rightarrow 10 \angle 0^\circ, \omega = 2 \text{ rad/s}$$

$$2H \Rightarrow j\omega L = j4 \Omega$$

$$0.1F \Rightarrow 1/j\omega C = -j5 \Omega$$

The equivalent circuit is now as shown in Fig. 8.10(b). Let

$$Z = -j5 \parallel 4 = \frac{-j5 \times 4}{4 - j5} = 2.439 - j1.951$$

By voltage division,

$$V_2 = \frac{1}{1+j4+Z} (10 \angle 0^\circ) = \frac{10}{3.439 + j2.049} = 2.498 \angle -30.79^\circ$$

In the time domain,

$$v_2 = 2.498 \cos(2t - 30.79^\circ) \tag{8.6.3}$$

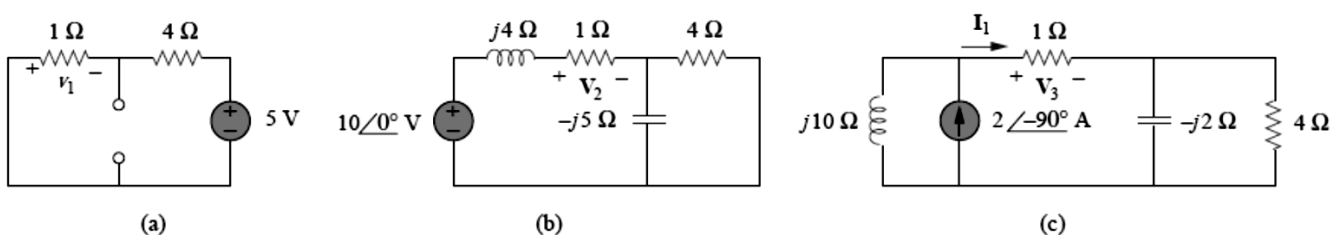

**Figure 8.10** Solution of Example 8.6: (a) setting all sources to zero except the 5-V dc source, (b) setting all sources to zero except the ac voltage source, (c) setting all sources to zero except the ac current source.

To obtain  $v_3$ , we set the voltage sources to zero and transform what is left to the frequency domain.

$$2 \sin 5t \Rightarrow 2 \angle -90^\circ, \omega = 5 \text{ rad/s}$$

$$2H \Rightarrow j\omega L = j10 \Omega$$

$$0.1F \Rightarrow 1/j\omega C = -j2 \Omega$$

The equivalent circuit is in Fig. 8.10(c). Let

$$Z_1 = -j2 \parallel 4 = \frac{-j2 \times 4}{4 - j2} = 0.8 - j1.6$$

By current division,

$$I_1 = \frac{j10}{j10 + 1 + Z_1} (2 \angle -90^\circ) A$$

$$V_3 = I_1 \times 1 = \frac{j10}{1.8 + j8.4} (-j2) = 2.328 \angle -77.91^\circ V$$

In the time domain,

$$v_3 = 2.33 \cos(5t - 80^\circ) = 2.33 \sin(5t + 10^\circ) V \tag{8.6.4}$$

Substituting Eqs. (8.6.2) to (8.6.4) into Eq. (8.6.1), we have

$$v_o(t) = -1 + 2.498 \cos(2t - 30.79^\circ) + 2.33 \sin(5t + 10^\circ) V$$

### 8.5 Source Transformation

As Fig. 8.11 shows, source transformation in the frequency domain involves transforming a voltage source in series with an impedance to a current source in parallel with an impedance, or vice versa. As we go from one source type to another, we must keep the following relationship in mind:

$$V_s = Z_s I_s \iff I_s = \frac{V_s}{Z_s} \tag{8.1}$$

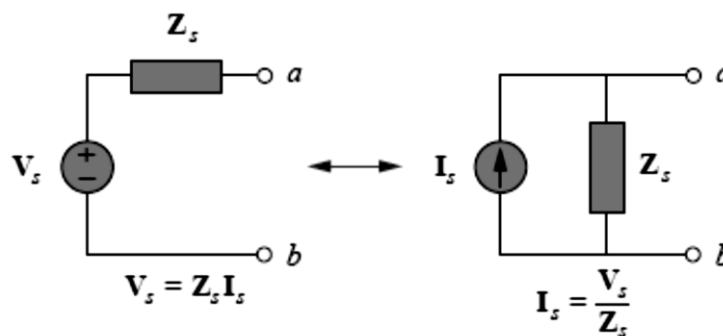

**Figure 8.11 Source transformation.**

**Example 8.7:** Calculate  $V_x$  in the circuit of Fig. 8.12 using the method of source transformation.

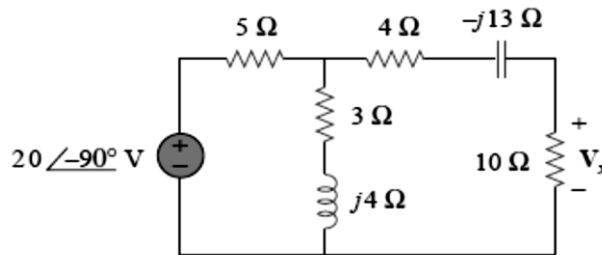

Figure 8.12 For Example 8.7.

**Solution:**

We transform the voltage source to a current source and obtain the circuit in Fig. 8.13(a), where

$$I_s = \frac{20 \angle -90^\circ}{5} = 4 \angle -90^\circ = -j4 \text{ A}$$

The parallel combination of 5-Ω resistance and (3+ j4) impedance gives

$$Z_1 = \frac{5(3 + j4)}{8 + j4} = 2.5 + j1.25 \text{ } \Omega$$

Converting the current source to a voltage source yields the circuit in Fig. 8.13(b), where

$$V_s = I_s Z_1 = -j4 (2.5 + j 1.25) = 5 - j10 \text{ V}$$

By voltage division,

$$V_x = \frac{10}{10 + 2.5 + j 1.25 + 4 - j13} (5 - j 10) = 5.519 \angle -28^\circ \text{ V}$$

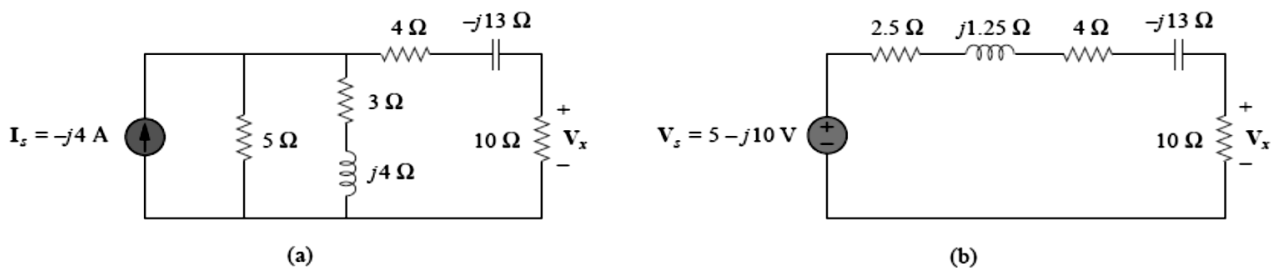

Figure 8.13 Solution of the circuit in Fig. 8.12.

### 8.6 Thevenin and Norton Equivalent Circuits

Thevenin's and Norton's theorems are applied to ac circuits in the same way as they are to dc circuits. The only additional effort arises from the need to manipulate complex numbers. The frequency-domain version of a Thevenin equivalent circuit is depicted in Fig. 8.14, where a linear circuit is replaced by a voltage source in series with an impedance. The Norton equivalent circuit is illustrated in Fig. 8.15, where a linear circuit is replaced by a current source in parallel with an impedance. Keep in mind that the two equivalent circuits are related as

$$\mathbf{V_{Th} = Z_N I_N, \quad Z_{Th} = Z_N} \tag{8.2}$$

just as in source transformation.  $V_{Th}$  is the open-circuit voltage while  $I_N$  is the short-circuit current.

If the circuit has sources operating at different frequencies (see Example 8.6, for example), the Thevenin or Norton equivalent circuit must be determined at each frequency. This leads to entirely different equivalent circuits, one for each frequency, not one equivalent circuit with equivalent sources and equivalent impedances.

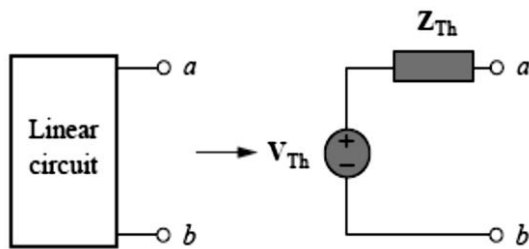

Figure 8.14 Thevenin equivalent.

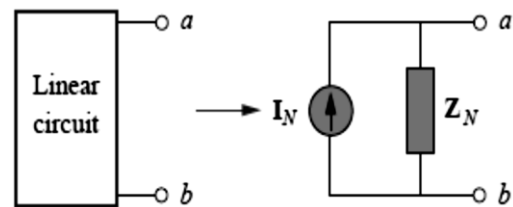

Figure 8.15 Norton equivalent.

**Example 8.8:** Obtain the Thevenin equivalent at terminals a-b of the circuit in Fig. 8.16.

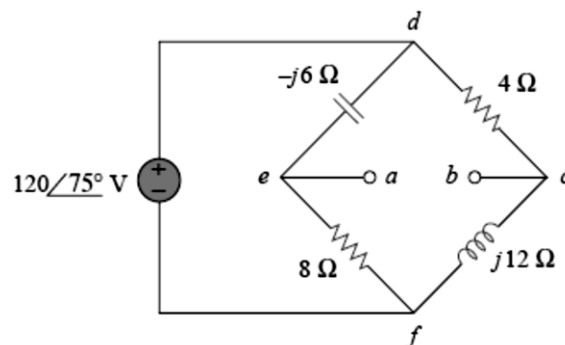

Figure 8.16 For Example 8.8.

**Solution:**

We find  $Z_{Th}$  by setting the voltage source to zero. As shown in Fig. 8.17(a), the  $8 \Omega$  resistance is now in parallel with the  $-j6$  reactance, so that their combination gives

$$\mathbf{Z1 = -j6 \parallel 8 = \frac{-j6 \times 8}{8 - j6} = 2.88 - j3.84 \Omega}$$

Similarly, the  $4\text{-}\Omega$  resistance is in parallel with the  $j12$  reactance, and their combination gives

$$\mathbf{Z2 = 4 \parallel j12 = \frac{j12 \times 4}{4 + j12} = 3.6 + j1.2 \Omega}$$

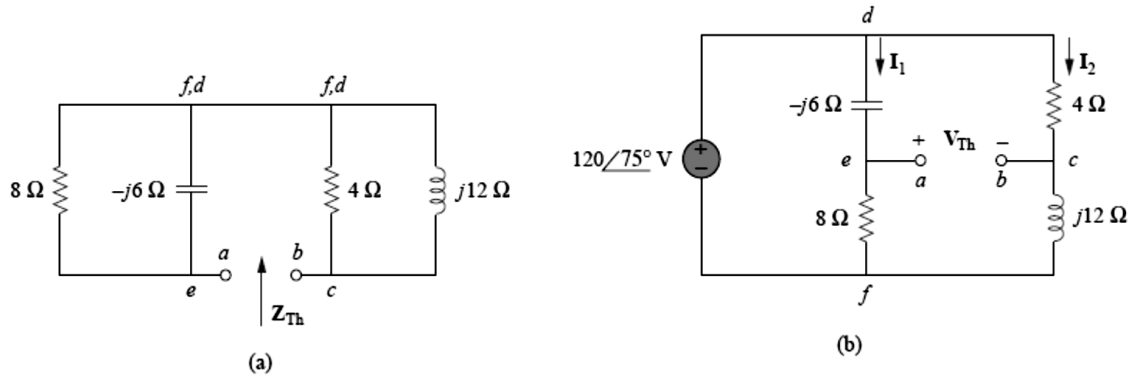

**Figure 8.17** Solution of the circuit in Fig. 8.16: (a) finding  $Z_{Th}$ , (b) finding  $V_{Th}$ .

The Thevenin impedance is the series combination of  $Z_1$  and  $Z_2$ ; that is,

$$Z_{Th} = Z_1 + Z_2 = 6.48 - j2.64 \Omega$$

To find  $V_{Th}$ , consider the circuit in Fig. 8.17(b). Currents  $I_1$  and  $I_2$  are obtained as

$$I_1 = \frac{120 \angle 75^\circ}{8 - j6} \text{ A}, \quad I_2 = \frac{120 \angle 75^\circ}{4 + j12} \text{ A}$$

Applying KVL around loop bcdeab in Fig. 8.17(b) gives

$$V_{Th} - 4I_2 + (-j6)I_1 = 0$$

or

$$\begin{aligned} V_{Th} &= 4I_2 + j6I_1 = \frac{480 \angle 75^\circ}{4 + j12} + \frac{720 \angle 75^\circ + 90^\circ}{8 - j6} \\ &= 37.95 \angle 3.43^\circ + 72 \angle 201.87^\circ \\ &= -28.936 - j24.55 = 37.95 \angle 220.31^\circ \text{ V} \end{aligned}$$

**Example 8.9:** Find the Thevenin equivalent of the circuit in Fig. 8.18 as seen from terminals a-b.

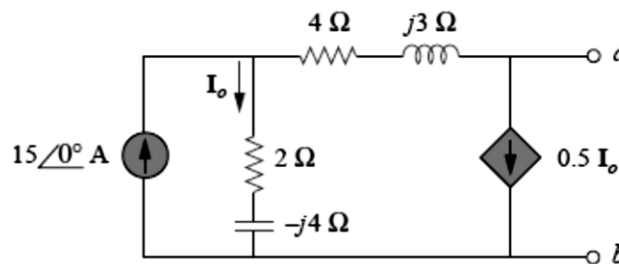

**Figure 8.18** For Example 8.9.

**Solution:**

To find  $V_{Th}$ , we apply KCL at node 1 in Fig. 8.19(a).

$$15 = I_o + 0.5 I_o \Rightarrow I_o = 10 \text{ A}$$

Applying KVL to the loop on the right-hand side in Fig. 8.19(a), we obtain

$$-I_o (2 - j4) + 0.5 I_o (4 + j3) + V_{Th} = 0$$

or

$$V_{Th} = 10(2 - j4) - 5(4 + j3) = -j55$$

Thus, the Thevenin voltage is

$$V_{Th} = 55 \angle -90^\circ \text{ V}$$

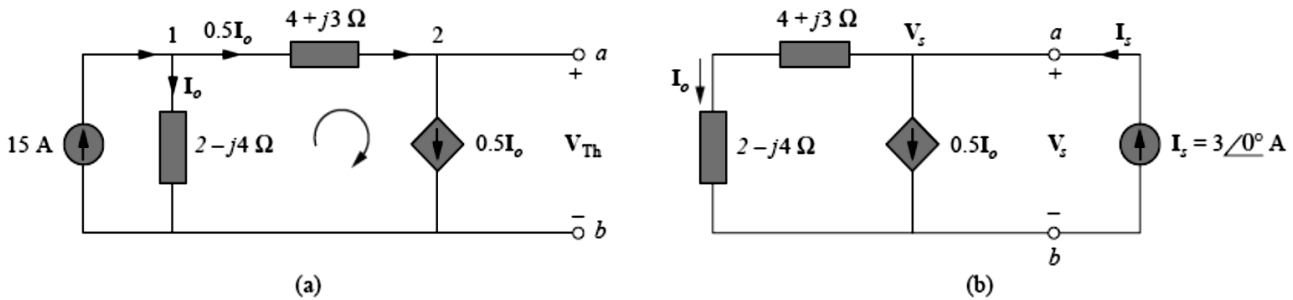

**Fig. 8.19** Solution of the circuit in Fig. 8.18

To obtain  $Z_{Th}$ , we remove the independent source. Due to the presence of the dependent current source, we connect a 3-A current source (3 is an arbitrary value chosen for convenience here, a number divisible by the sum of currents leaving the node) to terminals a-b as shown in Fig. 8.19(b). At the node, KCL gives

$$3 = I_o + 0.5I_o \Rightarrow I_o = 2\text{ A}$$

Applying KVL to the outer loop in Fig. 8.19(b) gives

$$V_s = I_o(4 + j3 + 2 - j4) = 2(6 - j)$$

The Thevenin impedance is

$$Z_{Th} = V_s / I_s = 2(6 - j) / 3 = 4 - j0.6667 \Omega$$

**Example 8.10:** Obtain current  $I_o$  in Fig. 8.20 using Norton's theorem.

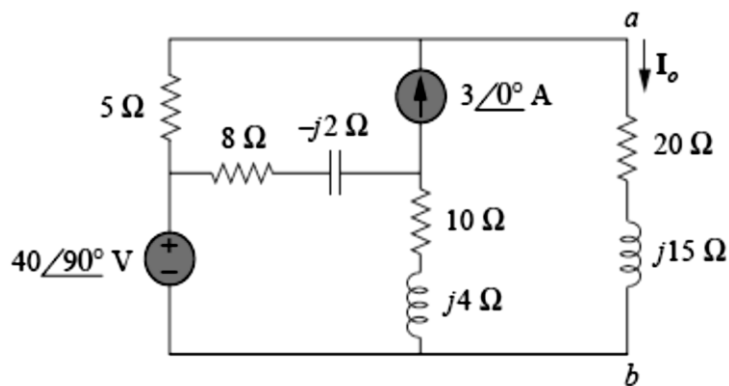

**Figure 8.20** For Example 8.10.

**Solution:**

Our first objective is to find the Norton equivalent at terminals a-b.  $Z_N$  is found in the same way as  $Z_{Th}$ . We set the sources to zero as shown in Fig. 8.21(a). As evident from the figure, the  $(8 - j2)$  and  $(10 + j4)$  impedances are short-circuited, so that

$$Z_N = 5 \Omega$$

To get  $I_N$ , we short-circuit terminals a -b as in Fig. 8.21(b) and apply mesh analysis. Notice that meshes 2 and 3 form a supermesh because of the current source linking them. For mesh 1,

$$-j40 + (18 + j2) I_1 - (8 - j2) I_2 - (10 + j4) I_3 = 0 \tag{8.10.1}$$

For the supermesh,

$$(13 - j2) I_2 + (10 + j4) I_3 - (18 + j2) I_1 = 0 \tag{8.10.2}$$

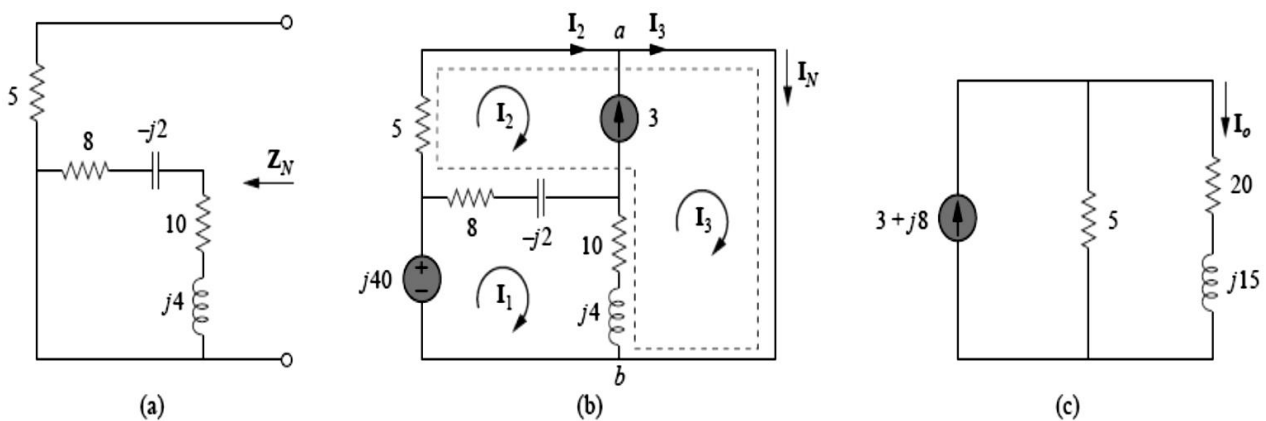

**Figure 8.21** Solution of the circuit in Fig. 8.20: (a) finding  $Z_N$ , (b) finding  $V_N$ , (c) calculating  $I_o$ .

At node a, due to the current source between meshes 2 and 3,

$$I_3 = I_2 + 3 \tag{8.10.3}$$

Adding Eqs. (8.10.1) and (8.10.2) gives

$$-j40 + 5I_2 = 0 \Rightarrow I_2 = j8$$

From Eq. (8.10.3),

$$I_3 = I_2 + 3 = 3 + j8$$

The Norton current is

$$I_N = I_3 = (3 + j8)$$

A Figure 8.21(c) shows the Norton equivalent circuit along with the impedance at terminals a-b.

By current division,

$$I_o = \frac{5}{5 + 20 + j15} I_N = \frac{3 + j8}{5 + j3} = 1.465 \angle 38.48^\circ A$$