

**Experiment name: Finding the capacitive will of a capacitor in the presence of an alternating voltage source.**

The objective of the experiment: to achieve Ohm's law in the case of alternating current.

Equipment used in the experiment:

- 1- power supply (source)
- 2- ammeter
- 3- Voltmeter
- 4- Connecting wires
- 5- resistance
- 6- wide

Theory: The capacitive resistor shows the opposite of the change in the circuit voltage, called the capacitive force ( $X_C$ ), measured in ohms and subject to Ohm's law, but it is not resistance and is not subject to Joule's thermal law.

The capacitance is calculated from the following relationships:

$$X_c = \frac{1}{\omega C}$$

$$X_c = \frac{1}{2\pi f C}$$

$$X_c = \frac{V_c}{I_c}$$

**The capacitive will depends on:**

1- The amplitude of the amplitude is inversely proportional to the nucleus frequency, i.e.

$$X_c \propto \frac{1}{C}$$

2 - The angular frequency is inversely proportional to it if the amplitude of the amplitude is fixed, that is:

$$X_c \propto \frac{1}{\omega}$$

It can be shown that the capacitive will is measured in ohms:

$$X_c = \frac{1}{2\pi fC} = \frac{1}{\frac{1}{\text{sec}} \cdot \text{Farad}} = \frac{1}{\frac{1}{\text{sec}} \cdot \frac{\text{Coulomb}}{\text{Volt}}} = \frac{\text{sec.Volt}}{\text{Amper.sec}} = \text{Ohm}$$

Observes the relationship between voltage and current for a circuit containing a pure inductor, which explains why the coil's impedance is generated in the case of alternating current, and since the capacitive input depends on the frequency, and the relationship is inverse. As the frequency increases, we notice the reading of the ammeter and the voltmeter, and as the frequency increases, the current in the ammeter increases, meaning that when the frequency increases, the current increases because the reluctance The capacitance I said, and we note that there is an inverse relationship between frequency and capacitive reluctance, and then find the graph:

We note from the drawing of the curve above that it represents voltage and current, where we find that the curve represents a top and a bottom, and where the chronological age is symbolized by the symbol  $t$ , which is located on the x-axis and the voltage and current on the y-axis. Sinusoidal voltage as in the above figure. If the voltage across the capacitor at a specific moment is  $v$ , then the instantaneous charge that the capacitor possesses at the same moment:

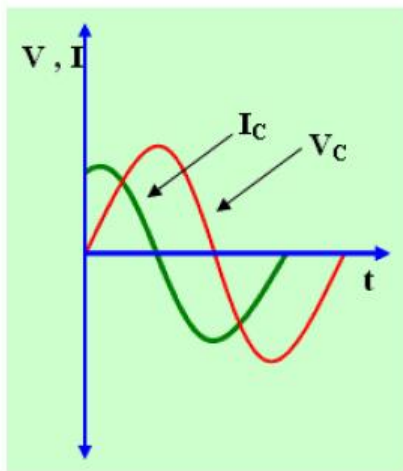

$$Q = cv = cv \sin \omega t$$

Here we note that when the voltage applied to the capacitor is a function of sine ( $\sin$ ), the current through that capacitor is a function of cosine ( $\cos$ ), and so the current is different in phase from the voltage in this circuit. The capacitive will ( $x_c$ ) known as the impedance is a kind of Resistance and electric current in the electrical device or electronic piece.. We show in this following circuit in Figure (1) that the current delivers a charge to a capacitor to create a potential difference between its ends. In other words, the current from its polarity is constantly in the case of a sinusoidal voltage signal, bringing a positive charge to one The two plates first and then bring them to the other, and that the alternating current continues the alternating voltage,

and that in the alternating current circuit, the average power consumed in the capacitor is ideally zero. Ohms for resistors, and the way to this is to know the interaction of the capacitor with the frequency of the voltage applied to it. The ability of the capacitor to impede the flow of charge is referred to by the term capacitive response or capacitive reactance through the law To the user in the experiment:

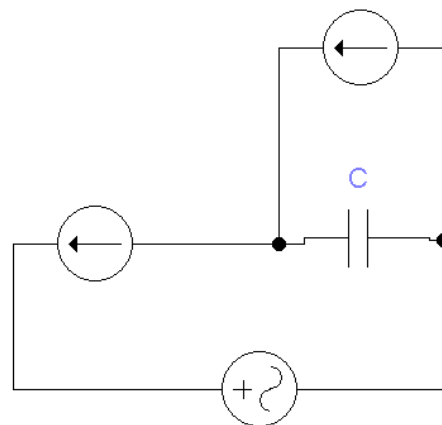

$$X_C = 1/2\pi fC$$

### The method of work :

- 1- Connect the electrical circuit
- 2- We start by increasing the voltage of the alternating source and record the value of the current  $I$  passing through the ammeter and the value of Voltage difference at both ends of the coil by a voltmeter and insert the readings into a table
- 3- According to the circuit from Action Generator, connect a wire to the ammeter on the alternator on (400) and from the ammeter to the resistance and from the resistance to the capacitor and from the capacitor to the signal generator device

4- There are voltmeters by which we measure the voltage on both ends of the capacitor or the resistance, but after we prove that the capacitive will is inversely proportional to the frequency at first, read the value of the current from less to 1 calculate the value of the current and the hertz, the higher the frequency, the greater the hertz

5- We draw the relationship between frequency and current, where the current is represented on the x-axis and the frequency  $f$  is on the y-axis.

**Discussion questions:**

1- What is the difference angle of the two turbines, the voltage vector and the current vector across the capacitor, and which is ahead of the other, voltage or current?

2- What is meant by the voluntary will and what are the factors that depend on it?

3- How does a capacitor behave when the frequency of the voltage 1-too high? 2-too low?