



Experiment No.2 R-C Series Circuit

1. Introduction

A resistor-capacitor circuit (RC circuit), or RC filter, is an electrical circuit composed of a passive component (resistors and capacitors) driven by a voltage or current source. The RC circuit can be used as a **low pass filter** to remove the higher frequency signals. Allowing the low-frequency signals to pass, the signals measured across the capacitor and have frequencies higher than the cut-off frequency will be removed. The RC circuit can also be used as a **high pass filter**, If the resistor and capacitor are switched, in their position. And the output signal across the resistor can be measured. A high pass filter is used to pass the high-frequency signals and removes the low-frequency signals.

2. Objectives

The experiment aims to study the electrical characteristics of an RC circuit in series. Also, to study the relation between the input frequency f and the circuit impedance X_C .

3. Components

- Function generator.
- Oscilloscope.
- Digital Multimeter.
- Resistor.
- Connection wires.
- Capacitor.

4. Theory:

When an ac voltage is applied to a resistor and a capacitor in series, as shown in Fig. 1, the capacitor will constantly charge and discharge as the input voltage (V_{in}) is constantly changing.

A **capacitor** C is formed whenever two conductors are separated by an insulating material. Consider the simple example of two parallel conducting plates separated by a small gap that is filled with an insulating material (vacuum, air, glass, or another dielectric). If a potential difference exists between the two plates, then an electric field exists between them, and opposite electric charges will be attracted to the two plates. The ability to store that electric charge is a fundamental property of capacitors. The larger the plates, the more charge can be stored. The closer the plates, the more charge can be stored...at least until the charges leap the gap and the dielectric breaks down. If a voltage source is connected across a capacitor, a charge will flow in the external circuit until the voltage across the capacitor is equal to the applied voltage. The charge that flows is proportional to the size of the capacitor its “capacitance” and to the applied voltage. The relationship is given by the equation

$$Q = CV \quad (1)$$

Where Q is the charge in coulombs, C is the capacitance in farads, and V is the applied voltage in volts.

In an RC circuit, the capacitive impedance X_c decreases as the frequency of the input voltage increases, and current I flow through the circuit is proportionally increased. i.e., as that frequency increases, the capacitor will act as a short circuit to the high-frequency current in its path. At low frequencies, the capacitor tends to block current flow. However, the change of the input frequency will not change the value of the resistor R .

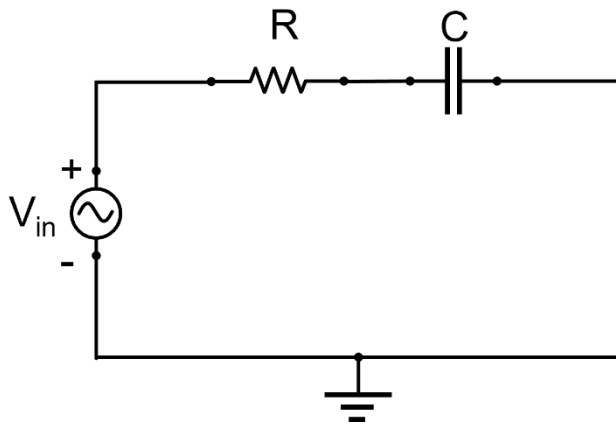

Figure 1: Schematic diagram illustrate an RC circuit connected in series

Reactance is a characteristic exhibited by capacitors and inductors in circuits with time-varying voltages and currents, such as common sinusoidal AC circuits. Like resistance, reactance opposes the flow of electric current and is measured in ohms. Capacitive reactance X_C can be found by the equation:

$$X_C = \frac{1}{2\pi f C} \quad (2)$$

Where f is the frequency of the applied voltage or current and C is the capacitance in farads. As with resistance, the capacitor reactance obeys Ohm's law:

$$V_C = I_C X_C \quad \text{or} \quad X_C = \frac{V_C}{I_C} \quad (3, 4)$$

If a sinusoidal voltage is applied across a purely resistive circuit, it produces a sine wave (sinusoidal) current. Both waveforms attain their peak values at the same time, and pass through zero at the same time. Voltage and current, in a purely resistive circuit, are therefore said to be "IN PHASE" with each other.

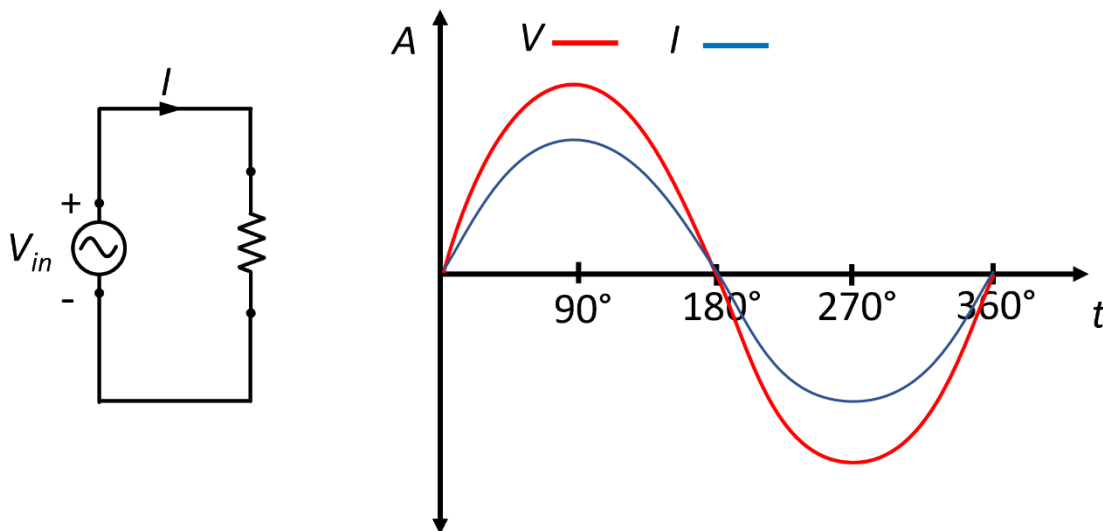

Figure 2: illustrate that the voltage and current wave are in phase in purely resistive load

In a purely capacitive circuit, the voltage and current waveforms are not in phase. Capacitance has the property of delaying changes in voltage. The applied voltage reaches steady state only after a time dictated by the time constant. In AC circuits voltage and

current are changing continuously, and in a purely capacitive AC circuit, the peak value of the voltage waveform occurs a quarter of a cycle after the peak value of the current. Therefore, a phase shift is occurring in the capacitor, the amount of phase shift between voltage and current is $+90^\circ$ for a purely capacitive circuit, with the current LEADING the voltage as shown in Fig. 3. The opposite phase shift to an inductive circuit.

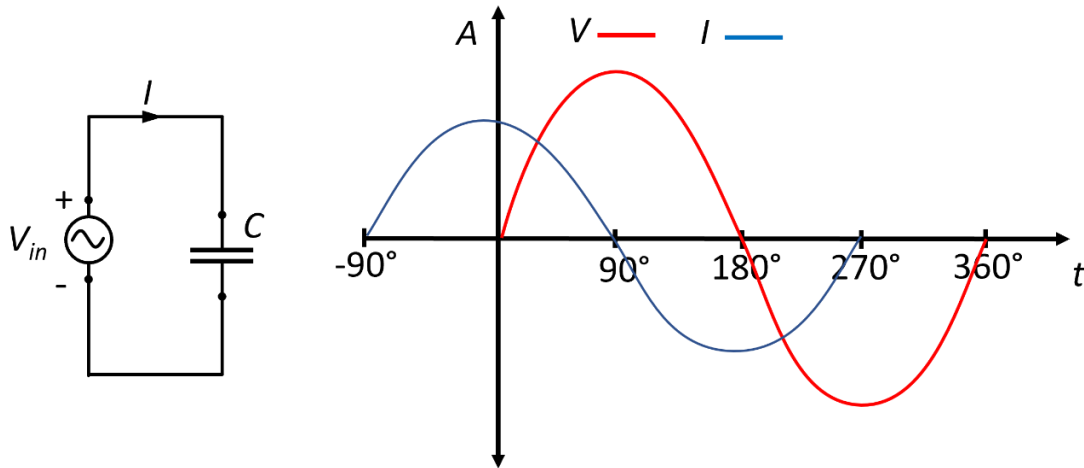

Figure 3: illustrate the voltage and current phase shift in a purely capacitive load

In an RC circuit, a phase shift occurs as well between the voltage across the capacitor V_C and the current I . As the circuit is a resistive-capacitive load, the current leads the voltage, as shown in Fig. 4. The phase shift can be calculated using equation 5.

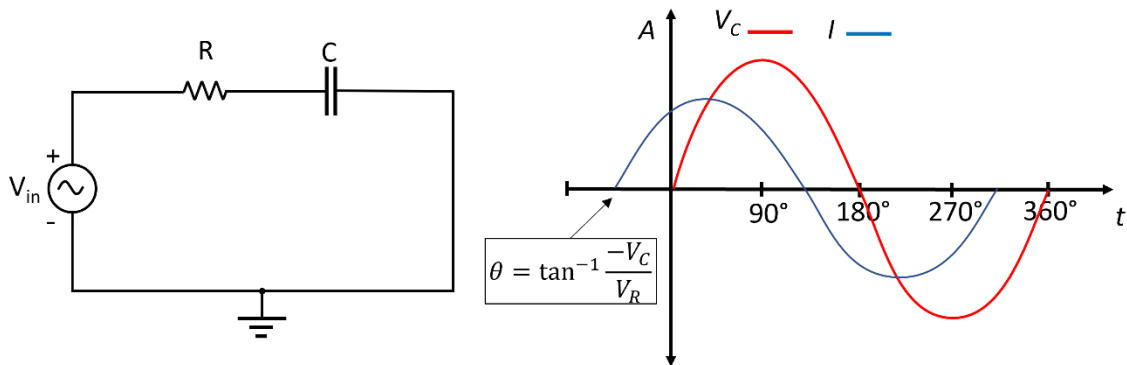

Figure 4: illustrate the voltage and current phase shift of a resistive-capacitive load.

$$\theta = \tan^{-1} \frac{-V_C}{V_R} \quad (5)$$

Table 1, shows important equations required to theoretically calculate V_R , V_C , V_s , R , X_C , and Z .

Table 1: Important equations

For voltages	For impedance
$ V_R = V_S \times \cos(\theta)$	$R = Z \times \cos(\theta)$
$ V_C = V_S \times \sin(\theta)$	$ X_C = Z \times \sin(\theta)$
$ V_S = \sqrt{ V_R ^2 + V_C ^2}$	$ Z = \sqrt{R^2 + X_C ^2}$

5. Experiment procedure

- 1- Build, connect the circuit shown in Fig. 1 using a $1\text{k}\Omega$ resistor and a $0.1\ \mu\text{F}$ capacitor.
- 2- Set the input voltage at 5V and frequency at $1\ \text{kHz}$.
- 3- Using the Oscilloscope, read the voltage across the $1\text{k}\Omega$ resistor and the $0.1\ \mu\text{F}$ capacitor.
- 4- Change the input voltage from 5 to 10 , 15 , and 20 volts.
- 5- Repeat step 3, measuring the voltage across the $1\text{k}\Omega$ resistor and the $0.1\ \mu\text{F}$ capacitor.
- 6- Based on the experimental measurement, Calculate the phase shift (θ) between V_R and V_C theoretically using equation 5.
- 7- Write down all the measured and calculated values.

6. Discussion

1. What is a capacitor and what consist of inside?
2. What are the applications of the RC circuit?
3. Why there is a phase shift (θ) between the measured voltage V_C and current I ?
4. If we increase the input frequency from 1kHz to $5\ \text{kHz}$, what is the phase shift (θ) between the voltage V_C and current I ?