



Experiment No.3

Half Wave Rectifier

Objectives:

- To calculate and draw the DC output voltages of half- wave rectifiers.
- Without smoothing capacitor and with smoothing capacitor.

Apparatus:

1. AC power supply or Function Generator.
2. Function Generator Oscilloscope.
3. Diode: Silicon D1N4007 .
4. Resistors: 10 k Ω , Capacitor 1 μ F

Theory:

Half Wave Rectifier:

A diode is a unidirectional conduction device. It conducts only when its anode is at a higher voltage with respect to its cathode. In a halfwave rectifier circuit, during positive half-cycle of the input, the diode gets forward biased and it conducts. Current flows through the load resistor R L and voltage is developed across it. During negative half-cycle of the input, the diode gets

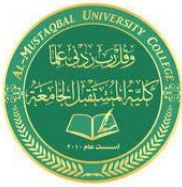

reverse biased. Now no current (except the leakage current which is very small) flow. The voltage across the load resistance during this period of input cycle is zero. Thus, a pure ac signal is converted into a unidirectional signal. It can be shown that (i) $V_{dc} = V_m/\pi$ Where, V_{dc} is the output DC voltage and V_m is peak AC voltage at the input the rectifier circuit.

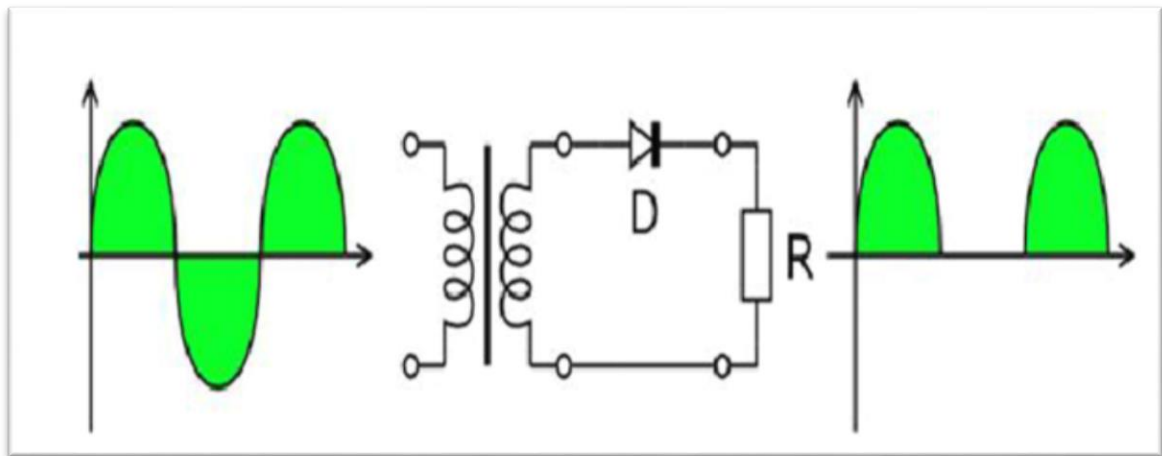

Procedure:

1. Connect the circuit as shown in Figure (1) using silicon diode. , adjust the power supply at 10 V.
2. Measure the input voltage V_1 and the output voltage V_2 using both the voltmeter and the oscilloscope.
3. Draw the input waveform, V_i , and the output waveform, V_o
4. Calculate:

a) Maximum voltage of the input signal

$$V_m = V_{p-p}/\sqrt{2}$$



b) the effective value of the input voltage

$$V = V_m / \sqrt{2}$$

c) the average value of the output voltage

$$V_{av} = V_{dc} = 0.318V_m$$

5. Connect the circuit as shown in Fig.2.

6. Draw the output waveform with Smoothing capacitor $C = 1\mu\text{F}$.

Discussion:

1. What is rectifier and what is the Ripple Factor?
2. what the effect of increasing or decreasing CL& R L?
3. what is the Efficiency find it for all result?

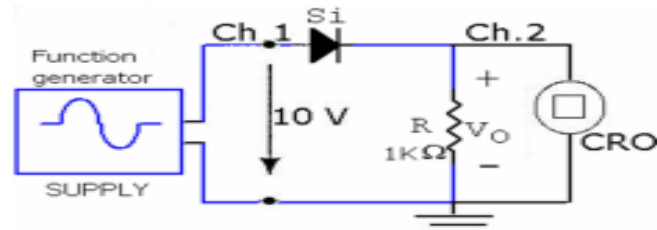

Fig.1

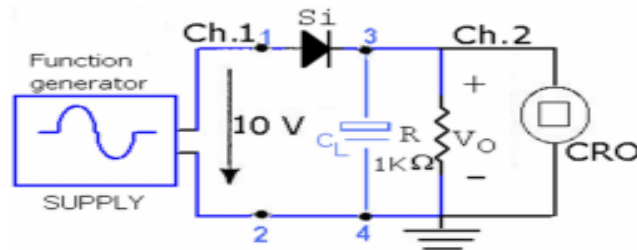

Fig.2