

Theoretical Lecture: Gradient coils

Magnetic Field Gradient

Whenever a magnetic field differs in magnitude or direction between two points in space, a magnetic gradient is said to exist.

The gradient (G) is defined as change in field (ΔB) divided by change in distance (Δs).

As a simple example, let us assume the magnetic field at the two ends of a horizontal bore scanner are 1.000 T and 1.002 T respectively, and that these locations are separated by 1 meter. The gradient is:

$$\text{Gradient} = (1.002 - 1.000) / 1 \\ = 2 \text{ mT/meter}$$

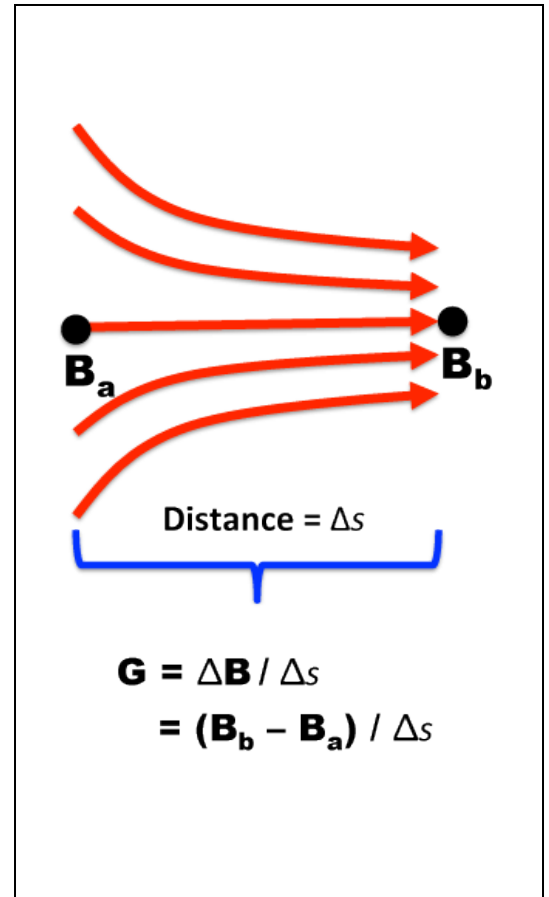
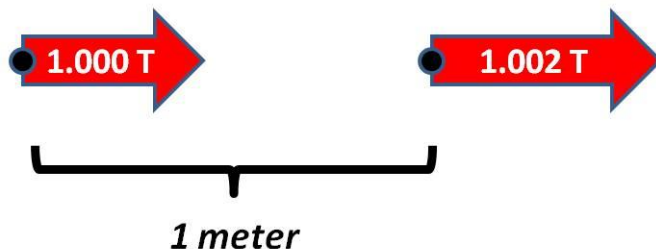

Gradient coils

A gradient coil set is an important component in a standard MRI scanner which produces linear gradient magnetic fields that are superimposed over a strong uniform magnetic field.

Gradients coils are loops of wire or thin conductive sheets on a cylindrical shell lying just inside the bore of an MR scanner. When current is passed through these coils a secondary magnetic field is created.

The uniform magnetic field is produced by a main magnet, which aligns with the proton precession direction. The superimposed gradient magnetic field slightly changes the proton precession frequency or phase, thus encoding the spatial information of an imaged object in the frequency associated with a position in space.

In a gradient assembly, there are three gradient coils, called the x, y, and z coils. **Figure 1** shows a set of actively shielded gradient coils. The red and blue colors of the gradient coils indicate where the current flows in clockwise and anticlockwise.

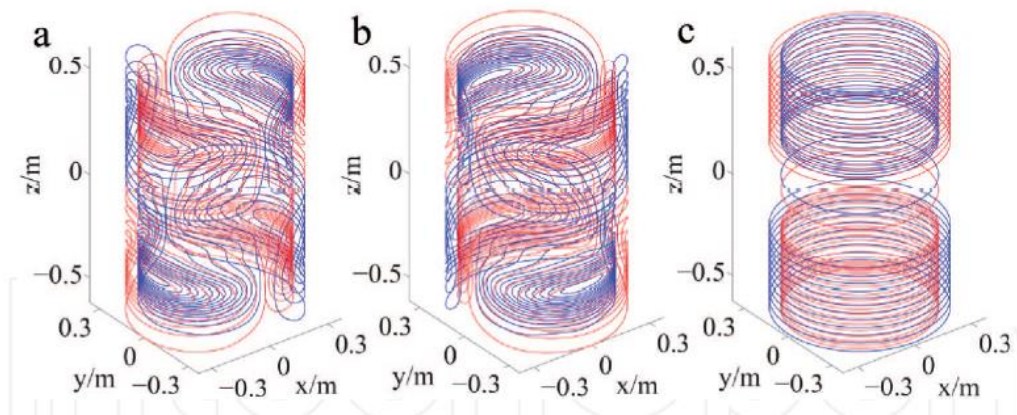

Figure 1A: Actively shielded gradient coils used in an MRI scanner: (a) x gradient coil, (b) y gradient coil, and (c) z gradient coil. The red and blue colors indicate the direction in which the current flows.

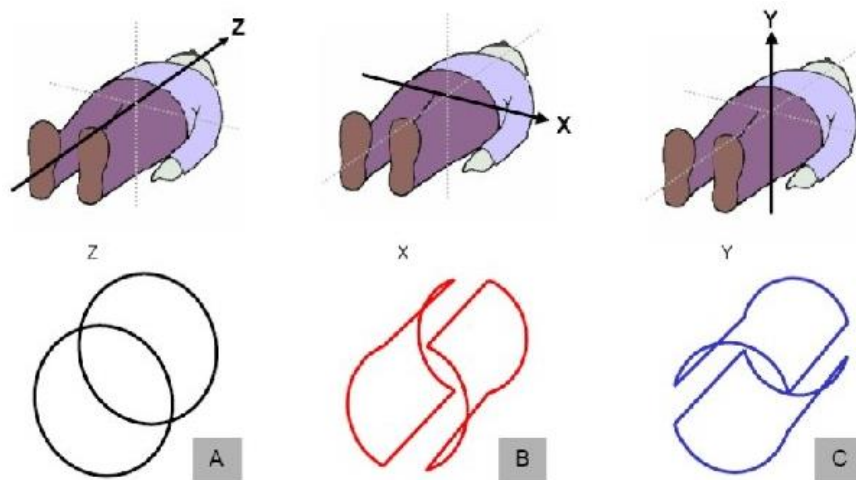

Figure 1B: shows three sets of wires. Each set creates magnetic field in a specific direction: Z, X and Y.

The three-axis gradient coils are fixed by epoxy resin in an encapsulated gradient assembly, as is shown in **Figure 2**. In an integrated gradient assembly, there are also cooling devices and a shim tray installed. The hard epoxy resin largely impedes the vibration of the gradient coils, which avoids torsion and deformation of the gradient coils under strong Lorentz force.

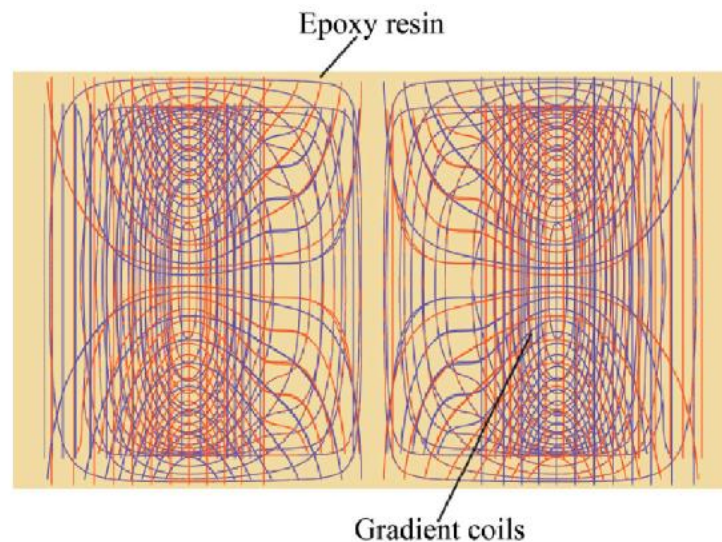

Figure 2: Illustration of the three-axis gradient coils fixed in the epoxy resin.

Spatial Encoding

Three sets of gradients are used along z, y and x axis and they are named as ***Slice Selection Gradient (SSG)***, ***Phase Encoding Gradient (PEG)*** and ***Frequency Encoding Gradient (FEG)***.

1- Slice Selection Gradient

The first step of spatial encoding consists in ***selecting the slice plane*** to do this:

MR image is made up of series of parallel slices, e.g. transverse slices, which are imaged in turn. Along with 90° pulse, the pair of Z-coil is energized with DC supply (Figure 3). This produces a controlled magnetic field gradient (SSG) along z-axis (cranial-caudal).

The total magnetic field increases at the head side and decreases at the toe side, remains the same at the isocenter. It varies from head to toe with constant increment of mT per m. Protons at precess at the toe side slowly, and are faster at the head side, and have moderate precession at the middle (null point) (**Figure 3&4**). The protons in the selected slice precess with narrow range of frequency.

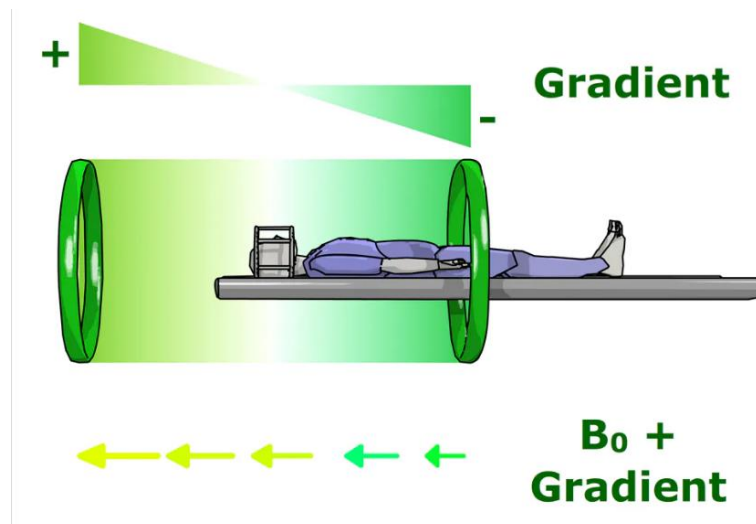

Figure 3: Z axis gradient coil, for slice selection

A narrow band RF pulse is applied to the whole volume and only protons in the thinner slice are excited. The spins along the gradient that have a precessional frequency equal to RF will absorb energy due to resonance. The magnetic vectors of the above spins will tip and gives MR signal. As none of the protons located outside the slice plane are excited, they will not emit a signal.

The slice thickness depends on

- (i) RF bandwidth.
- (ii) Gradient strength across FOV.

Slice thickness is reduced either by:

- (i) increasing the gradient magnetic field
- (ii) Decreasing the RF bandwidth.

Properties of thinner slice:

- 1- gives better anatomical detail with lesser partial volume effect
- 2- Takes longer time.
- 3- Typical slice thickness range is 2–10 mm.

A gap equal to **10%** of slice thickness should be kept in between slices, because RF may excite tissues on either side of the selected slice, since it has higher or lower frequency about the bandwidth and generate signal. This is called cross talk, which affects the image slice.

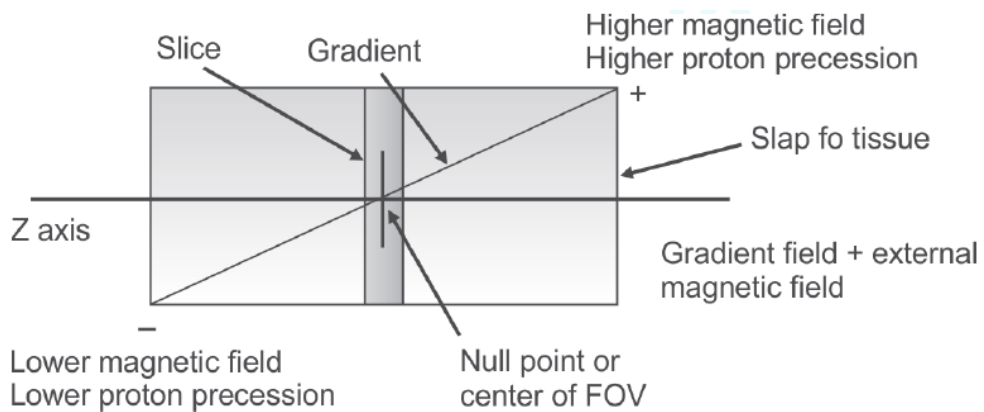

Figure 4: Gradient magnetic field makes the proton slower at the toe side and faster at the head side and moderate precession at the middle (null point).

2- Phase Encoding Gradient

The second step in spatial encoding consists in applying a phase encoding gradient. The protons in the slice are excited initially by 90° pulse, which are in phase coherence. Now, the Y gradient coil is switched on for few ms by DC voltage (Figure 5).

It produces magnetic field gradient, along y direction (front to back). Spins in the upper (front) voxel precess faster, and that are in the bottom (back) precess slowly.

Thus, spins in the bottom voxel lags behind that of upper voxel. Even if the gradient pulse is over, all precess at the same rate, but phase differences exist,

depending on the position (figure 6). Thus, MR signal has phase variation from different pixel of tissue, in the selected slice.

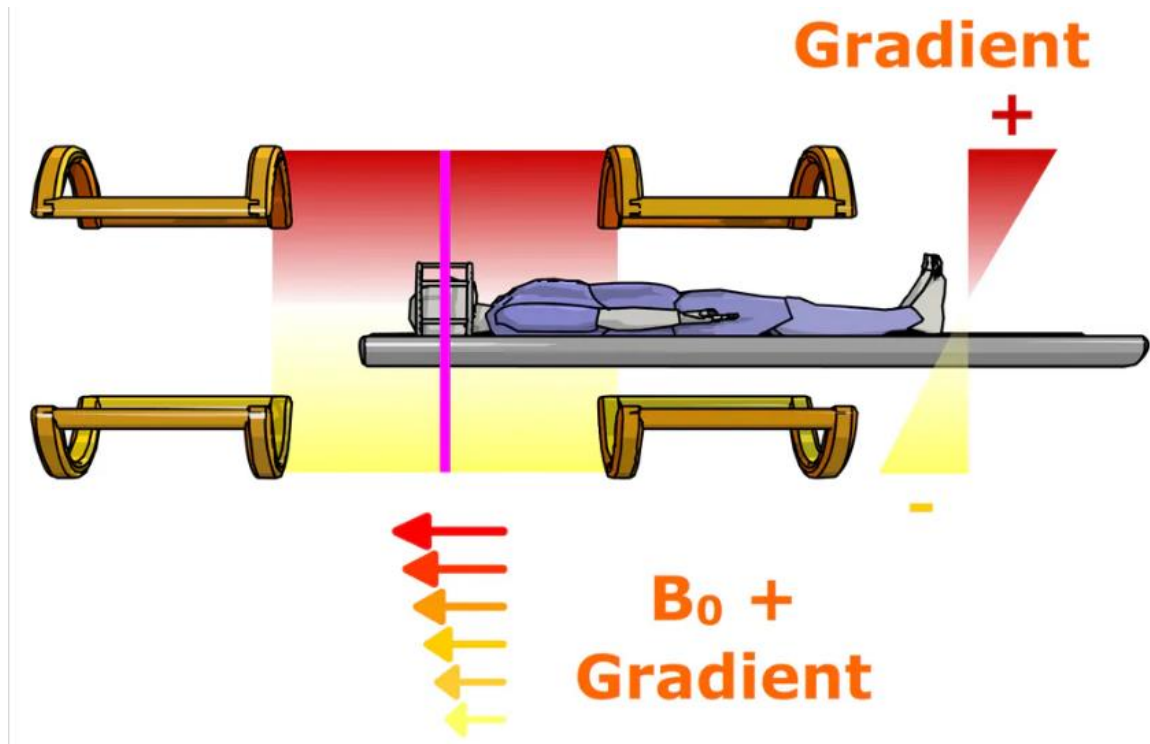

Figure 5: Y-axis gradient coil, for phase encoding gradient.

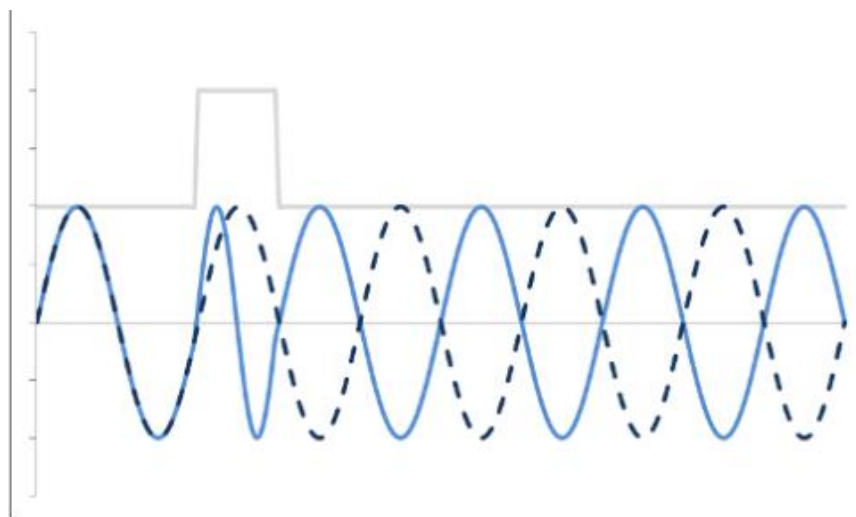

Figure 6: phase shift in phase encoding gradient.

Frequency Encoding Gradient

The final step in spatial encoding consists in applying a frequency encoding gradient (FEG). When the gradient field is applied in X- direction, X-gradient coil (Figure 7) is energized, applied in orthogonal direction (patient side-side).

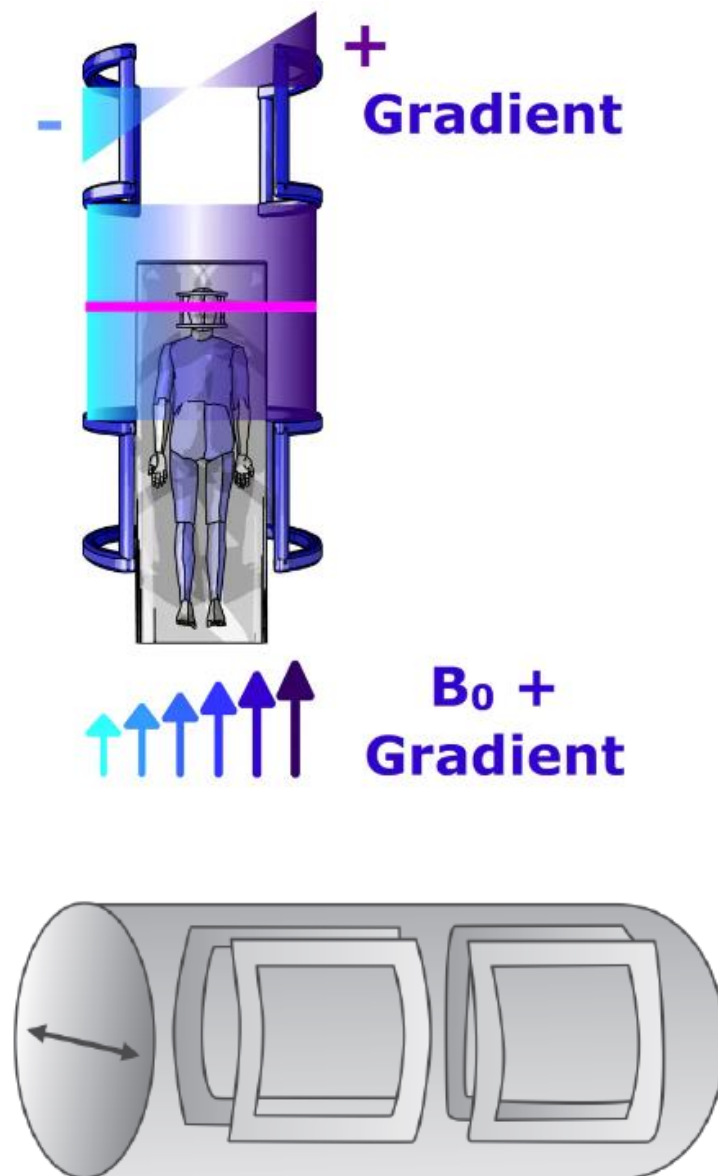

Figure 7: X-axis gradient coil, for frequency encoding

Protons in a vertical column experience same magnetic field and emit MR signal of same frequency. Spins in the left side precess slowly, and that in right precess faster, resulting in a frequency gradient from left to right. The MR

signal from a given slice consists of range of RF frequencies, on either side of the applied pulse.

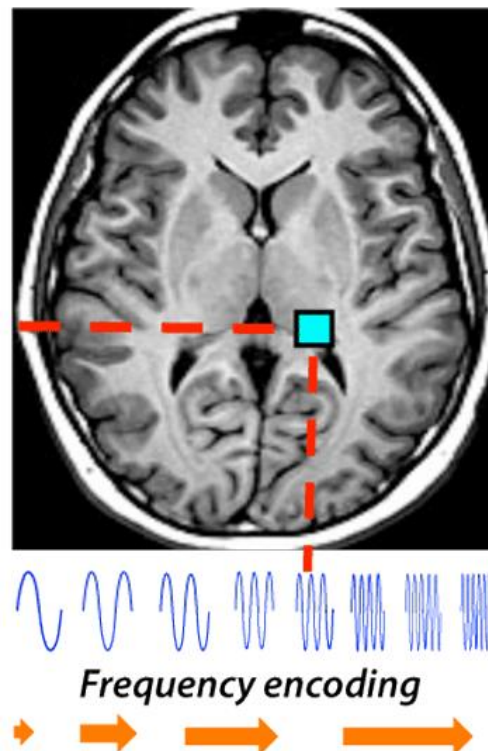

Figure 8: shows the frequency encoding gradient begins at the left side of the image and increases along the horizontal direction to the right side

Questions:

- 1- Find the magnetic gradient, if the magnetic field at the two ends of a horizontal bore scanner are 1.000 T and 1.002 T respectively?
- 2- What are the Gradients coils? And why the gradient coils are fixed by epoxy resin?
- 3- What occur when gradient magnetic field applied along the Z-Direction?
- 4- The reasons of thinner slices are better?
- 5- Why should be kept a gap equal to 10% of slice thickness in between slices?
- 6- What occur when the magnetic field gradient applied along Y axis?
- 7- What is the frequency encoding gradient with drawing?