

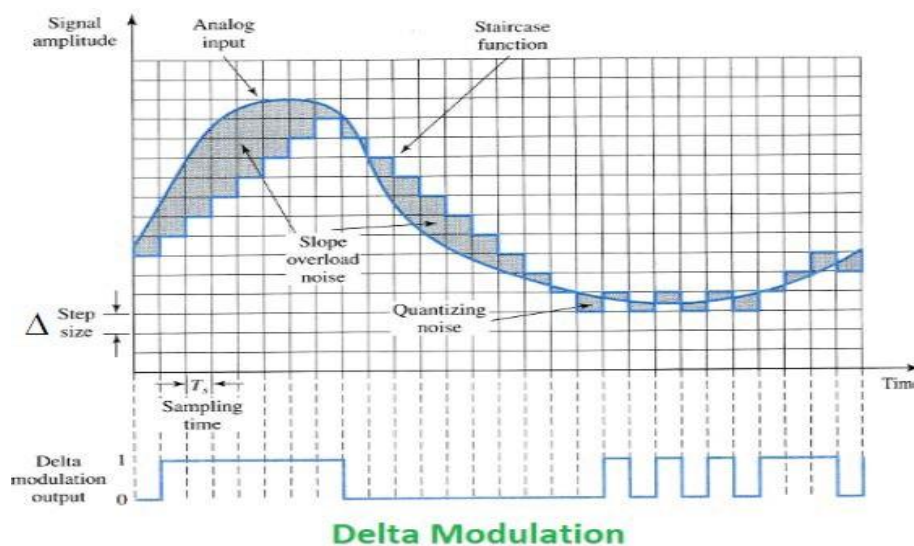

Delta modulation (DM)

In the basic form, DM provides a stair case approximation to the over sampled version of the message signal, as shown in figure below, the difference between the input and the approximation is quantized into only two levels, namely, $\pm \Delta$, corresponding to positive and negative differences, respectively. Thus, if the approximation below the signal at any sampling epoch, it is increased by Δ , on the other hand, the approximation lies above the signal, it is diminished by Δ .



Denoting the input signal as $m(t)$, and its stair case approximation as $m_q(t)$, the basic principle of DM may be formalized in the following set of discrete time relations:-

$$e(nT_s) = m(nT_s) - m_q(nT_s - T_s) \quad \dots\dots\dots(a)$$

$$e_q(nT_s) = \Delta \text{Sgn}[e(nT_s)] \quad \dots\dots\dots(b)$$

$$m_q(nT_s) = m_q(nT_s - T_s) + e_q(nT_s) \quad \dots\dots\dots(c)$$

where

T_s =sampling time, $e(nT_s)$ =error signal representing difference between $m(nT_s)$ and the latest approximation to it $m(nT_s)-m_q(nT_s-T_s)$, $e_q(nT_s)$ =the quantized version of $e(nT_s)$.

Finally, the quantizer output $e_q(nT_s)$ coded to produce the DM signal.

DM modulator and demodulator are shown below.

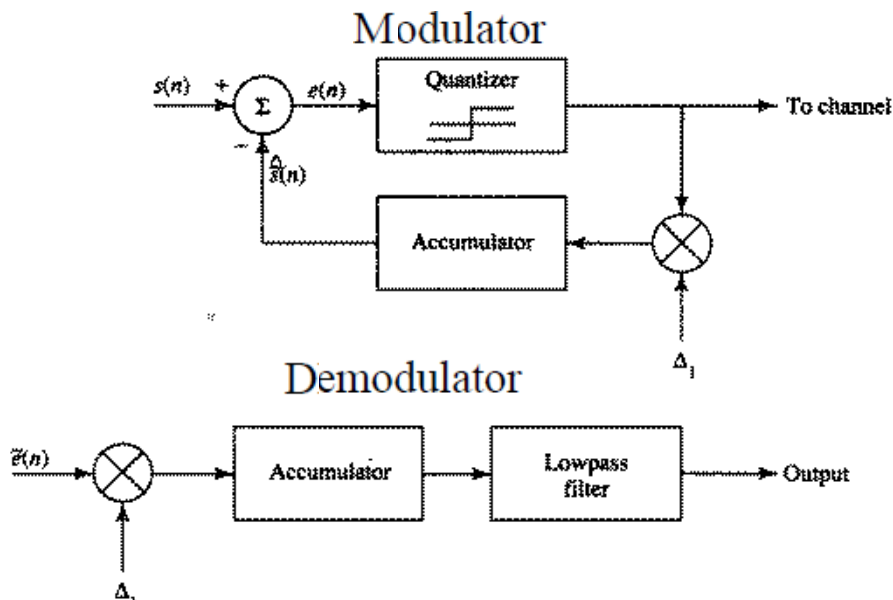



The comparator computes the difference between two inputs. The quantizer consists of hard limiter with an input/output relation that is scaled version of the signum function. The accumulator increments the approximation by a step Δ in positive or negative direction, depending on the algebraic sign of the error signal $e(nT_s)$.

Demodulation is subjected to two types of error:-

- (1) Slop over load direction.
- (2) Granular noise.

Equation (c) may be observed as a digital equivalent of integration in the sense that it represents the accumulation of positive and negative increments of magnitude Δ , also, denoting the quantization error by $q(nT_s)$, as shown by

$$m_q(nT_s) = m(nT_s) + q(nT_s)$$

From equation (a) may be observed

$$e(nT_s) = m(nT_s) - m(nT_s - T_s) - q(nT_s - T_s)$$

Thus, except for the quantization error $q(nT_s - T_s)$, the quantizer input is a first backward difference of the input signal, which may be viewed as a digital approximation to the derivative of the input signal or, equivalently, as the inverse of the digital integration process.

Consider the maximum slope of input $m(t)$, it is clear that in order for the sequence of samples $m_q(nT_s)$ to increase as fast as the input sequence of samples $m(nT_s)$ in a region of maximum slope of $m(t)$, the condition

$$\frac{\Delta}{T_s} \geq \left| \frac{dm(t)}{dt} \right|$$

This condition must be satisfied.

It is therefore clear that the choice of optimum step size that minimize the mean square value of quantization error in a linear delta modulator will be the result of a compromise between slope overload distortion and granular distortion. To satisfy such a requirement, the modulator must be made (*adaptive*) in the sense that the step size is made to vary in accordance with the input signal.

❖ Adaptive delta modulation

Adaptive delta modulation is a delta modulation where the step size (Δ) is automatically varied depending on the amplitude characteristics of the analog input signal, as shown in figure below.

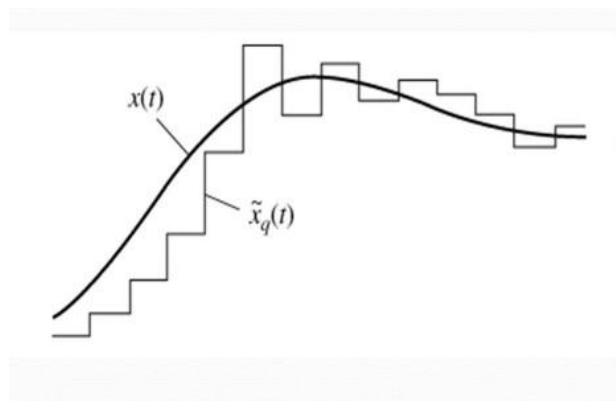



Example

A Delta modulator is used to encode speech signal band-limited to 3KHz with sampling frequency 100 KHz. For ± 1 volt peak signal voltage, find Minimum step size to avoid slope overloading.

Solution:-

For DM system, if input signal $f(t) = b \cos \omega_m t$.

$$(a) \therefore \left| \frac{df(t)}{dt} \right|_{\max} = b 2 \pi f_m$$

if step size used in DM system= a

$$\therefore f_s \geq \frac{2 \pi f_m}{a/b}$$

$$\therefore a \geq \frac{2 \pi f_m b}{f_s}$$

$$\frac{2 \pi * 3 * 10^3 * 1}{100 * 10^3} = 0.188V \text{ minimum step size.}$$

➤ Channel Capacity

The maximum rate of transmission was found by Shannon to be given by:-

$$C = W \log_2 (1 + S/N)$$

Shannon's maximum capacity expression provides an upper bound on the rate at which one can communicate over a channel of bandwidth W , and signal to noise ratio SNR .