



Class: 1st

Subject: Mechanical Engineering

Lecturer: Mays Khalid Mohammad

E-mail: mays.khalid@mustaqbal-college.edu.iq

Lecture No. / 4



RESULTANTS

The resultant of a system of forces is the simplest force combination which can replace the original forces without altering the external effect on the rigid body to which the forces are applied.

The most common type of force system occurs when the forces all act in a single plane, say, the x - y plane, as illustrated by the system of three forces F_1 , F_2 , and F_3 in Figure. We obtain the magnitude and direction of the resultant force R by forming the *force polygon* shown in part *b* of the figure

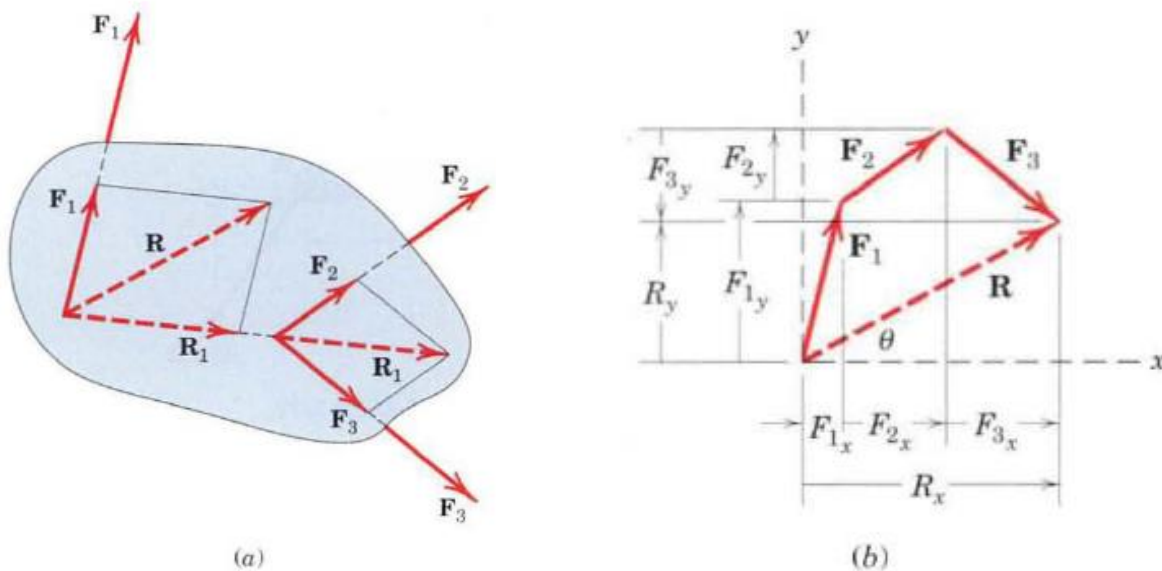

$$\mathbf{R} = \mathbf{F}_1 + \mathbf{F}_2 + \mathbf{F}_3 + \dots = \Sigma \mathbf{F}$$
$$R_x = \Sigma F_x \quad R_y = \Sigma F_y \quad R = \sqrt{(\Sigma F_x)^2 + (\Sigma F_y)^2}$$
$$\theta = \tan^{-1} \frac{R_y}{R_x} = \tan^{-1} \frac{\Sigma F_y}{\Sigma F_x}$$

Principle of Moments

This process is summarized in equation form by

$$\mathbf{R} = \Sigma \mathbf{F}$$
$$M_O = \Sigma M = \Sigma (Fd)$$
$$Rd = M_O$$



Problem 1

Determine the resultant of the four forces and one couple which act on the plate shown.

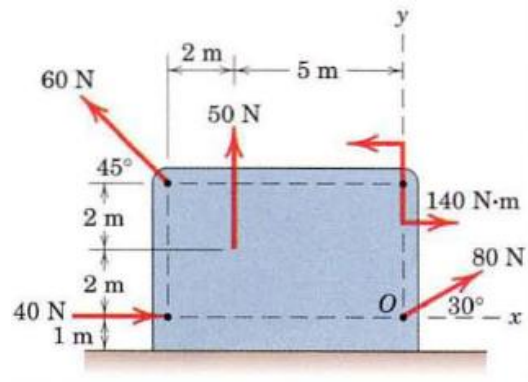

Solution

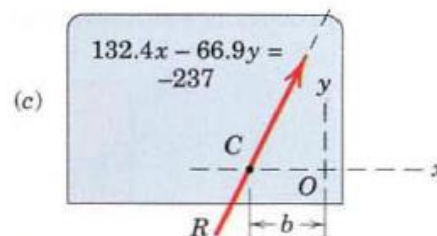
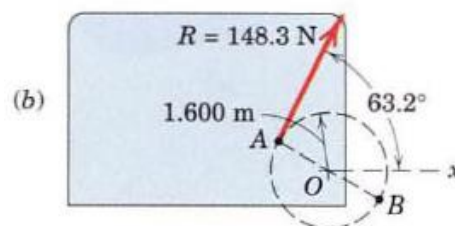
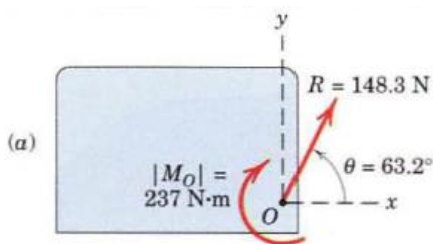

$[R_x = \Sigma F_x]$	$R_x = 40 + 80 \cos 30^\circ - 60 \cos 45^\circ = 66.9 \text{ N}$	
$[R_y = \Sigma F_y]$	$R_y = 50 + 80 \sin 30^\circ + 60 \cos 45^\circ = 132.4 \text{ N}$	
$[R = \sqrt{R_x^2 + R_y^2}]$	$R = \sqrt{(66.9)^2 + (132.4)^2} = 148.3 \text{ N}$	Ans.
$\left[\theta = \tan^{-1} \frac{R_y}{R_x} \right]$	$\theta = \tan^{-1} \frac{132.4}{66.9} = 63.2^\circ$	Ans.
$[M_O = \Sigma(Fd)]$	$M_O = 140 - 50(5) + 60 \cos 45^\circ(4) - 60 \sin 45^\circ(7)$ $= -237 \text{ N}\cdot\text{m}$	

$[Rd = M_O]$	$148.3d = 237 \quad d = 1.600 \text{ m}$
----------------	--



Problem 2

Determine and locate the resultant R of the two forces and one couple acting on the I-beam.

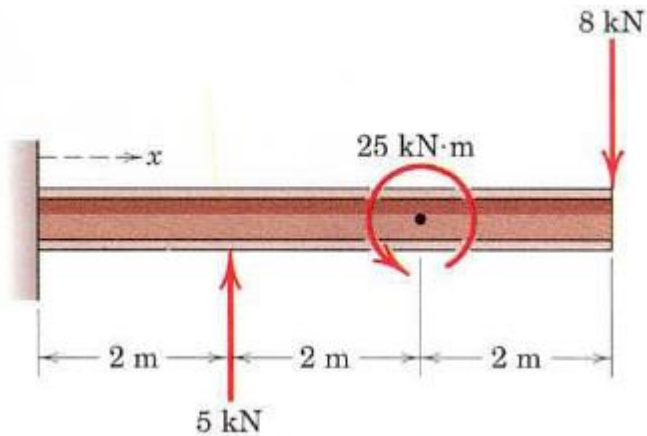

Solution

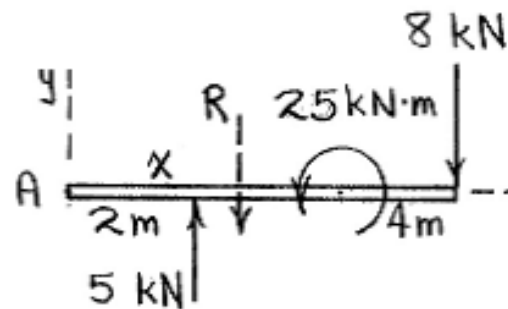

$$R = \sum F_y = 5 - 8 = \underline{-3 \text{ kN}}$$
$$\uparrow + |R|x = M_A : 3x = -5(2) - 25 + 8(6)$$
$$\underline{x = 4.33 \text{ m}}$$



Class: 1st

Subject: Mechanical Engineering

Lecturer: Mays Khalid Mohammad

E-mail: mays.khalid@mustaqbal-college.edu.iq

Lecture No. / 4



Homework 4

A commercial airliner with four jet engines, each producing 90 kN of forward thrust, is in a steady, level cruise when engine number 3 suddenly fails. Determine and locate the resultant of the three remaining engine thrust vectors. Treat this as a two dimensional problem.

