



Class: 2nd stage

Subject: Physical Chemistry



**Ministry of Higher Education and Scientific Research
Al-Mustaqbal University College**

**Chemical engineering and petroleum industries
(Physical Chemistry lab)**

Experiment No.6

**(Determination of Surface Tension of Liquids By Du
Nouy ring method)**

Prepared by

Asst.Lect. Sarah Ali Abdul Hussein

Asst.Lect. Zahraa Abdulelah Hadi

Asst.Lect. Rand Fadel Kadim

Eng. Ahmed Abbas Mohammed



Class: 2nd stage

Subject: Physical Chemistry



Determination of Surface Tension of Liquids by Du Nouy ring method

Theory:

Surface Tension is the phenomenon that occurs when the surface of a liquid is in contact with another phase (it can be a liquid as well). The surface of the liquid behaves like an elastic sheet.

The surface tension of a liquid results from an imbalance of intermolecular attractive forces, the *cohesive forces* between molecules:

- A molecule in the bulk liquid experiences cohesive forces with other molecules in all directions.
- A molecule at the surface of a liquid experiences only net inward cohesive forces.

In another words, the surface tension arises due to cohesive interactions between the molecules in the liquid. At the bulk of the liquid, the molecules have neighboring molecules on each side. Molecules are pulling each other equally in all directions causing a net force of zero. However, at the interface, the liquid molecules have only half of the neighboring liquid molecules compared to the bulk of the liquid. This makes the molecule associate more strongly with the molecules at its sides and causes a net inward force towards the liquid. This force resists the breakage of the surface and is called surface tension.

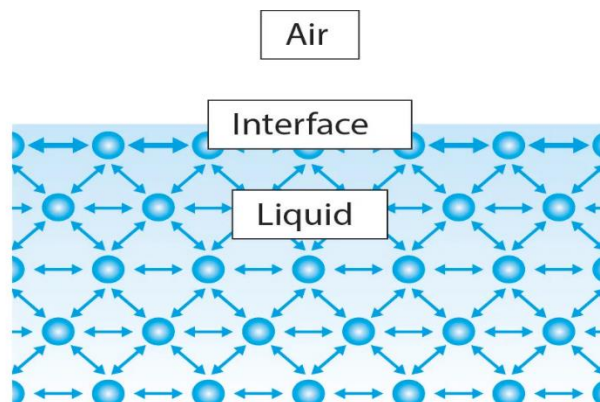



Class: 2nd stage

Subject: Physical Chemistry



The effect of temperature on surface tension:

As the temperature of a liquid increases, its surface tension decreases. When water heats up, the movement of its molecules disrupts the imbalanced forces on the surface of the water and weakens its sheet-like barrier of tightly bound molecules, thereby lowering the surface tension.

Aim of the experiment:

-To determine the surface tension of liquid (Water).

Equipment:

-Water, Du Nouy Ring Tensiometer.





Class: 2nd stage

Subject: Physical Chemistry



Procedure of the Du Nouy Ring Method:

Du Nouy Ring Tensiometer - uses a platinum ring that is submersed in a liquid. When the ring is pulled out of the liquid, the tension required is measured to determine the surface tension of the liquid.

Discussion:

1. How do you explain surface tension?
2. Which liquid has the highest surface tension and why?
3. why hot water is more effective when it uses for cleaning?