

Moment

As a familiar example of the concept of moment, consider the pipe wrench of Fig. a. One effect of the force applied perpendicular to the handle of the wrench is the tendency to rotate the pipe about its vertical axis. The magnitude of this tendency depends on both the magnitude F of the force and the effective length d of the wrench handle. Figure b shows a two-dimensional body acted on by a force F in its plane. The magnitude of the moment or tendency of the force to rotate the body about the axis $O-O$ perpendicular to the plane of the body is proportional both to the magnitude of the force and to the *moment arm* d , which is the perpendicular distance from the axis to the line of action of the force

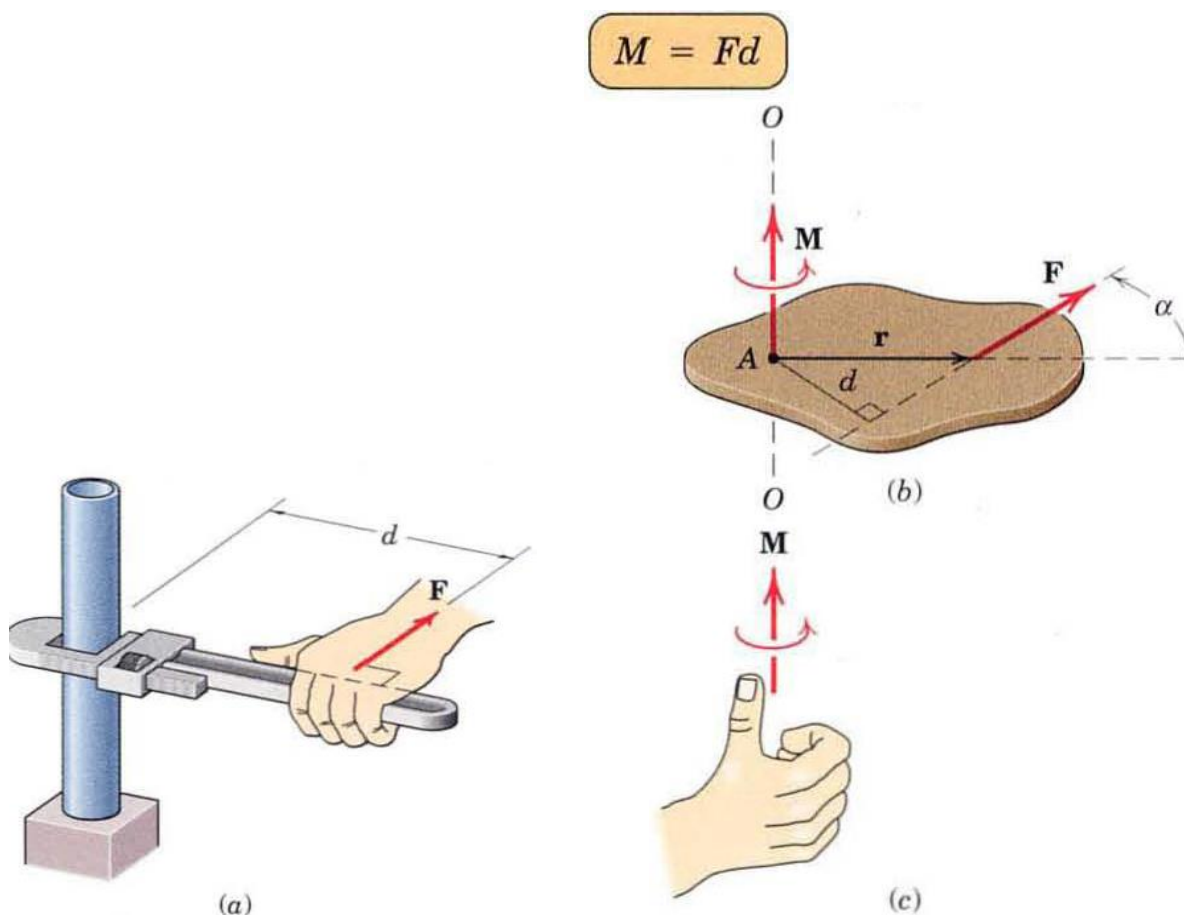

Problem1

Calculate the magnitude of the moment about the base point O of the 600-N

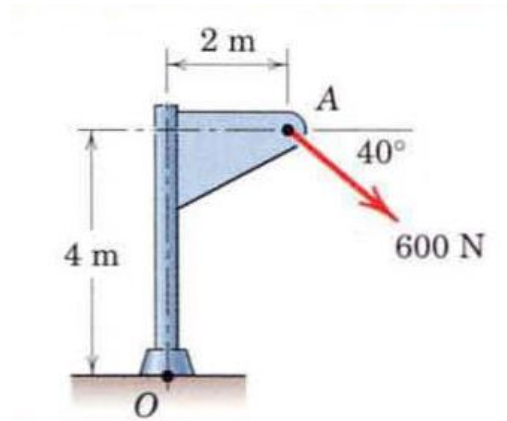

Solution

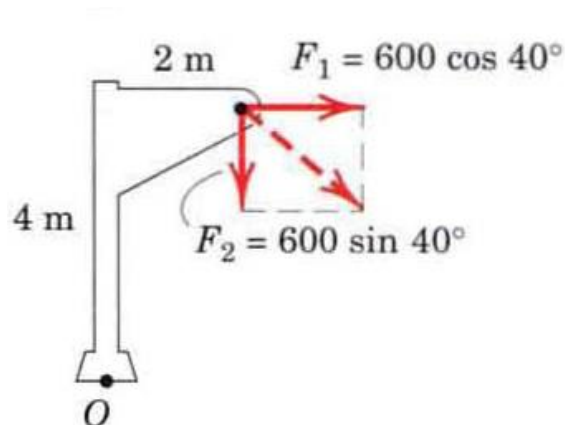

Replace the force by its rectangular components at A

$$F_1 = 600 \cos 40 = 460 \text{ N}$$

$$F_2 = 600 \sin 40 = 386 \text{ N}$$

$$M_o = 460(4) + 386(2) = 2610 \text{ N}\cdot\text{m}$$

Problem 2

A force F of magnitude 40 N is applied to the gear. Determine the moment of F about point O .

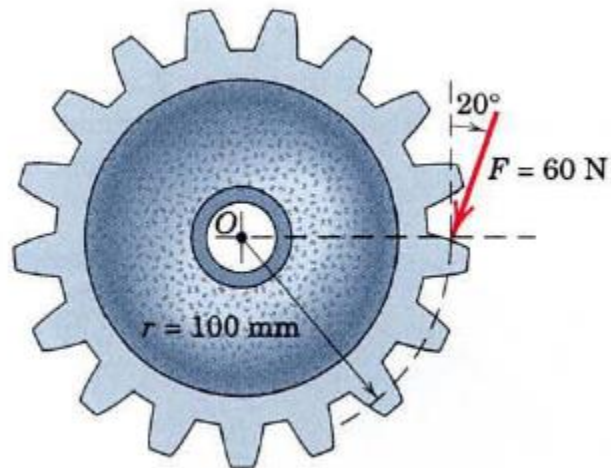

Solution/

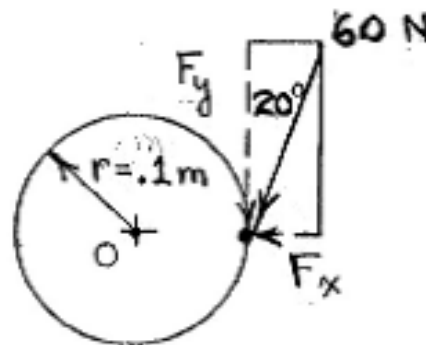

$$\begin{aligned} +2 M_o &= r F_y \\ &= (0.1) (60 \cos 20^\circ) \\ &= \underline{5.64 \text{ N}\cdot\text{m}} \end{aligned}$$

Homework 3/

Calculate the moment of the 250·N force on the handle of the monkey wrench about the center of the bolt.

