

5. Steam Power Plants

Steam power plants operate on the principles derived from the first and second laws of thermodynamics. The thermodynamic power cycle that is the basic concept of steam power plants is called **Rankine cycle**. In a simple Rankine cycle; water is heated, turns into steam and spins a steam turbine which drives an electrical generator. After it passes through the turbine, the steam is condensed in a condenser and recycled to where it was heated.

Rankine Cycle

A schematic diagram of a steam power plant and a (T - S) diagram of a simple ideal Rankine cycle are shown in figure below. The ideal Rankine cycle does not involve any internal irreversibilities and consists of the following four processes:

Process (1-2), isentropic compression in a pump: water enters the pump at state 1 as saturated liquid and is compressed isentropically to the operating pressure of the boiler. The water temperature increases somewhat during this isentropic compression process.

Process (2-3), constant pressure heat addition in a boiler: water enters the boiler as compressed liquid at state 2 and leaves as superheated vapor at state 3. The boiler is basically a large heat exchanger where the heat originating from a heat source is transferred to the water at constant pressure. The boiler, together with the section where the steam is superheated (the superheater), is often called the steam generator.

Process (3-4), isentropic expansion in a turbine: the superheated vapor at state 3 enters the turbine, where it expands isentropically and produces work by rotating the connected shaft. The pressure and temperature of steam drop during this process to the values at state 4, where steam enters the condenser. At this state, steam is usually a saturated liquid–vapor mixture with high quality.

Process (4-1), constant pressure heat rejection in a condenser: at state 4, steam is condensed at constant pressure in the condenser by rejecting heat to a cooling medium. Steam leaves the condenser as saturated liquid at state 1 and enters the pump completing the cycle.

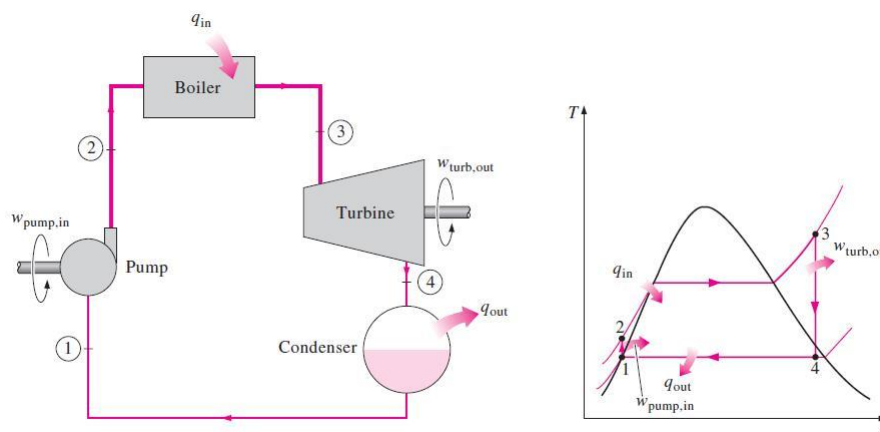

Simple Ideal Rankine Cycle

The area under the process curve on a (T - S) diagram represents the heat transfer for internally reversible processes, it can be seen that the area under the process curve (2-3) represents the heat transferred to the water in the boiler and the area under the process curve (4-1) represents the heat rejected in the condenser. The difference between these two (the area enclosed by the cycle) is the net work produced during the cycle.

Energy Analysis of the Cycle

All four components associated with the Rankine cycle (pump, boiler, turbine, and condenser) are steady-flow devices, and thus all four processes that make up the Rankine cycle can be analyzed as steady-flow processes. The kinetic and potential energy changes of the steam are usually small relative to the work and heat transfer terms and are therefore usually neglected. Then the steady-flow energy equation per unit mass of steam can be expressed as follows:

$$(q_{in} - q_{out}) + (w_{pump} - w_{turbine}) = h_e - h_i$$

- For pump: $q = 0$ and $w_{pump} = h_2 - h_1$
 or $w_{pump} = v(P_2 - P_1)$
- where: $h_1 = h_f$ and $v = v_1 = v_f$ at P_1
- For boiler: $w = 0$ and $q_{in} = h_3 - h_2$
- For turbine: $q = 0$ and $w_{turbine} = h_3 - h_4$
- For condenser: $w = 0$ and $q_{out} = h_4 - h_1$

$$W_{net} = W_{turbine} - W_{pump} = q_{in} - q_{out}$$

$$\eta_{th} = \frac{W_{net}}{q_{in}} = 1 - \frac{q_{out}}{q_{in}}$$

Example (5.1): A steam power plant operates on a simple ideal Rankine cycle between the pressure limits of 3 MPa and 50 kPa. The temperature of the steam at the turbine inlet is 300°C, and the mass flow rate of steam through the cycle is 35 kg/s. Show the cycle on a (T - S) diagram with respect to the saturation lines, and determine: (a) the thermal efficiency of the cycle (b) the net power output of the power plant.

Solution:

$$h_1 = h_f = 340.54 \text{ kJ/kg} \quad \text{at} \quad P_1 = 50 \text{ kPa}$$

$$v_1 = v_f = 0.00103 \text{ m}^3/\text{kg} \quad \text{at} \quad P_1 = 50 \text{ kPa}$$

$$w_{pump} = v(P_2 - P_1) = 0.00103 \times (3000 - 50) = 3.04 \text{ kJ/kg}$$

$$w_{pump} = h_2 - h_1 \rightarrow h_2 = h_1 + w_{pump} = 340.54 + 3.04 = 343.58 \text{ kJ/kg}$$

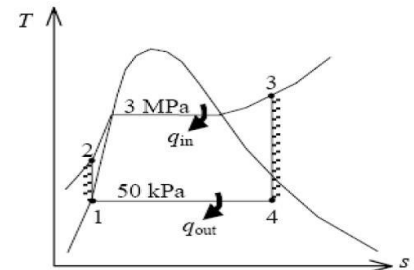

At $P_3 = 3 \text{ Mpa}$ and $T_3 = 300^\circ\text{C} \rightarrow h_3 = 2994.3 \text{ kJ/kg}$ and $s_3 = 6.5412 \text{ kJ/kg}\cdot\text{K}$

$$\text{At } P_4 = 50 \text{ kPa and } s_4 = s_3 \rightarrow x_4 = \frac{s_4 - s_f}{s_{fg}} = \frac{6.5412 - 1.0912}{6.5019} = 0.8382$$

$$h_4 = h_f + x_4 \cdot h_{fg} = 340.54 + 0.8382 \times 2304.7 = 2272 \text{ kJ/kg}$$

$$q_{in} = h_3 - h_2 = 2994.3 - 343.58 = 2650.6 \text{ kJ/kg}$$

$$q_{out} = h_4 - h_1 = 2272.3 - 340.54 = 1931.8 \text{ kJ/kg}$$

$$w_{net} = q_{in} - q_{out} = 2650.6 - 1931.8 = 718.9 \text{ kJ/kg}$$

$$\eta_{th} = 1 - \frac{q_{out}}{q_{in}} = 1 - \frac{1931.8}{2650.7}$$

$$\eta_{th} = 27.1\% \quad \text{Ans.}$$

$$\text{Power} = \dot{m} \times w_{net} = 35 \times 718.9$$

$$\text{Power} = 25.2 \text{ kW} \quad \text{Ans.}$$

Actual Rankine Cycle

The actual cycle differs from the ideal Rankine cycle as a result of irreversibilities in various components. Fluid friction and heat loss to the surroundings are the main sources of irreversibilities.

Fluid friction causes pressure drops in the boiler, condenser and the piping between various components. As a result, steam leaves the boiler at a somewhat lower pressure. Also, the pressure at the turbine inlet is somewhat lower than that at the boiler exit due to the pressure drop in the connecting pipes. The pressure drop in the condenser is usually very small. To compensate for these pressure drops, the water must be pumped to a higher pressure than the ideal cycle calls for. This requires a larger pump and larger work input to the pump.

The other major source of irreversibility is the heat loss from the steam to the surroundings as the steam flows through various components. To maintain the same level of net work output, more heat needs to be transferred to the steam in the boiler to compensate for these undesired heat losses. As a result, cycle efficiency decreases.

Of particular importance are the irreversibilities occurring within the **pump** and the **turbine**. A pump requires a greater work input, and a turbine produces a smaller work output as a result of irreversibilities. Under ideal conditions, the flow through these devices is isentropic. The deviation of actual pumps and turbines from the isentropic ones can be accounted for by utilizing isentropic efficiencies, defined as:

$$\eta_P = \frac{w_{Ps}}{w_{Pa}} = \frac{h_{2s} - h_1}{h_{2a} - h_1} \quad \text{For pump}$$

$$\eta_T = \frac{w_{Ta}}{w_{Ts}} = \frac{h_3 - h_{4a}}{h_3 - h_{4s}} \quad \text{For turbine}$$

Where states **2a** and **4a** are the actual exit states of the pump and the turbine respectively, and **2s** and **4s** are the corresponding states for the isentropic case.

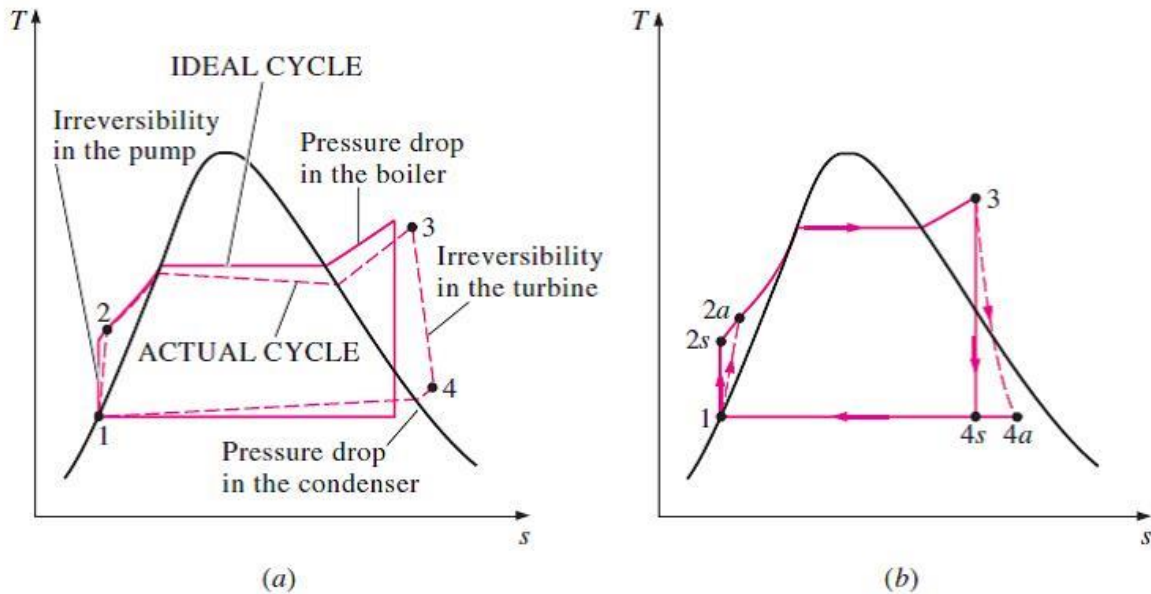

(a) Deviation of actual vapor power cycle from the ideal Rankine cycle. (b) The effect of pump and turbine irreversibilities on the ideal Rankine cycle.

Example (5.2): A steam power plant operates on the cycle shown in the figure below. If the isentropic efficiency of the turbine is 87% and the isentropic efficiency of the pump is 85%, determine: (a) the thermal efficiency of the cycle (b) the net power output of the plant for a mass flow rate of 15 kg/s.

Solution:

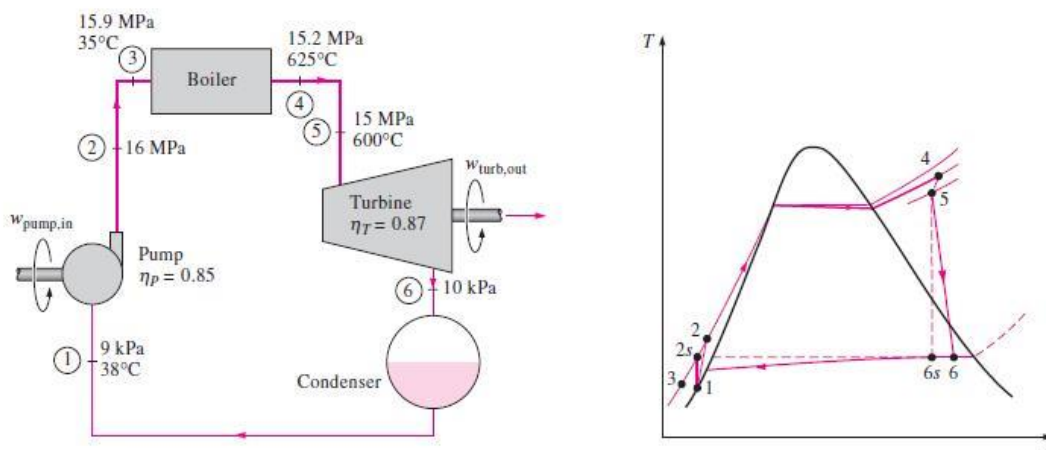

a. The thermal efficiency of the cycle is the ratio of the net work output to the heat input.

$$\eta_P = \frac{w_{Ps}}{w_{Pa}} = \frac{v_1(P_2 - P_1)}{w_{Pa}} \rightarrow w_{Pa} = \frac{v_1(P_2 - P_1)}{\eta_P}$$

$$w_{Pa} = \frac{0.001009 \times (16 \times 10^3 - 9)}{0.85} = 18.98 \text{ kJ/kg}$$

$$\eta_T = \frac{w_{Ta}}{w_{Ts}} \rightarrow w_{Ta} = \eta_T \times w_{Ts} = \eta_T \times (h_5 - h_{6s})$$

$$w_{Ta} = 0.87 \times (3583.1 - 2115.3) = 1277 \text{ kJ/kg}$$

$$w_{net} = w_{Ta} - w_{pa} = 1277 - 18.98 = 1258.02 \text{ kJ/kg}$$

$$q_{add} = h_4 - h_3 = 3647.6 - 160.1 = 3487.5 \text{ kJ/kg}$$

$$\eta_{th} = \frac{w_{net}}{q_{add}} = \frac{1258.02}{3487.5}$$

$$\eta_{th} = 36.1\% \quad \text{Ans.}$$

b. The net power output of the plant is:

$$Power = \dot{m} \times w_{net} = 15 \times 1258.02$$

$$Power = 18.9 \text{ kW} \quad \text{Ans.}$$

Improving the Rankine Cycle Efficiency

Steam power plants are responsible for the production of most electric power in the world, and even a small increase in thermal efficiency can mean large savings from the fuel requirements.

The basic idea behind all the modifications to increase the thermal efficiency of a power cycle is the same: **Increase the average temperature at which heat is transferred to the working fluid in the boiler, or decrease the average temperature at which heat is rejected from the working fluid in the condenser.** Three ways can be illustrated to accomplish the subject:

1. Lowering the condenser pressure: lowering the operating pressure of the condenser automatically lowers the temperature of the steam, and thus the temperature at which heat is rejected. The effect of lowering the condenser pressure on the Rankine cycle efficiency is illustrated on the (T - S) diagram in the following figure. For comparison purposes, the turbine inlet state is maintained the same. The shaded area on this diagram represents the increase in net work output as a result of lowering the condenser pressure from P_4 to P'_4 .

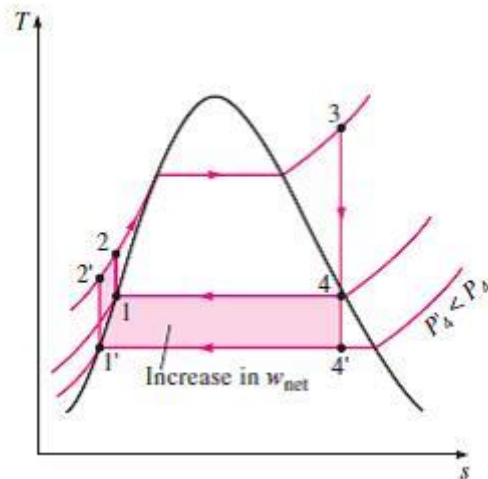

2. Superheating the Steam at High Temperature: the average temperature at which heat is transferred to steam can be increased without increasing the boiler pressure by superheating the steam to high temperatures. The effect of superheating on the performance of vapor power cycles is illustrated on a (T - S) diagram in the following figure. The shaded area on this diagram represents the increase in the net work. The total area under the process curve 3-3' represents the increase in the heat input. Thus both the net work and heat input increase as a result of superheating the steam to a higher temperature. The overall effect is an increase in thermal efficiency, however, since the average temperature at which heat is added increases.

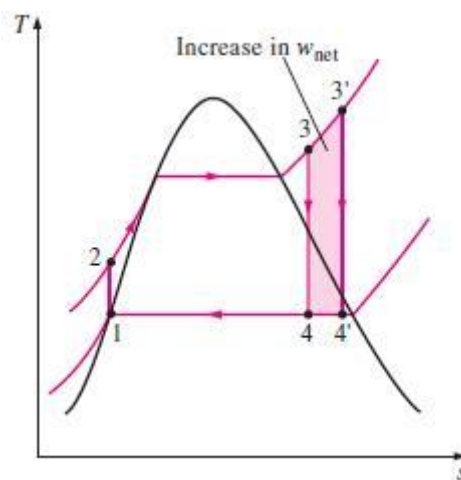

3. Increasing the Boiler Pressure: another way of increasing the average temperature during the heat addition process is to increase the operating pressure of the boiler, which automatically raises the temperature at which boiling takes place. This, in turn, raises the average temperature at which heat is transferred to the steam and thus raises the thermal efficiency of the cycle. The effect of increasing the boiler pressure on the performance of vapor power cycles is illustrated on a (T - S) diagram in the following figure. Notice that for a fixed turbine inlet temperature, the cycle shifts to the left and the moisture content of steam at the turbine exit increases. This undesirable side effect can be corrected.

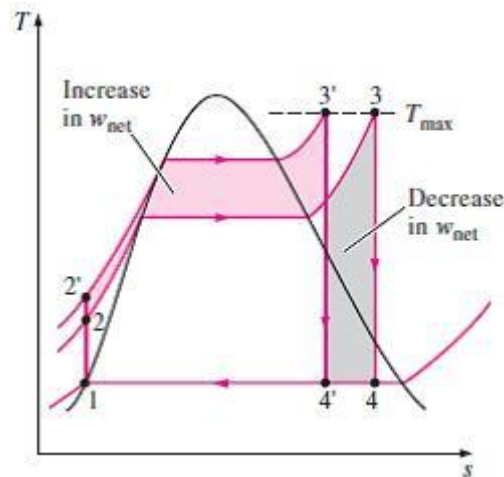

Example (5.3): Consider a steam power plant operating on an ideal Rankine cycle. Steam enters the turbine at 3 MPa and 350°C and is condensed in the condenser at a pressure of 10 kPa. Determine: (a) the thermal efficiency of this power plant (b) the thermal efficiency if steam is superheated to 600°C instead of 350°C (c) the thermal efficiency if the boiler pressure is raised to 15 MPa while the turbine inlet temperature is maintained at 600°C.

Solution:

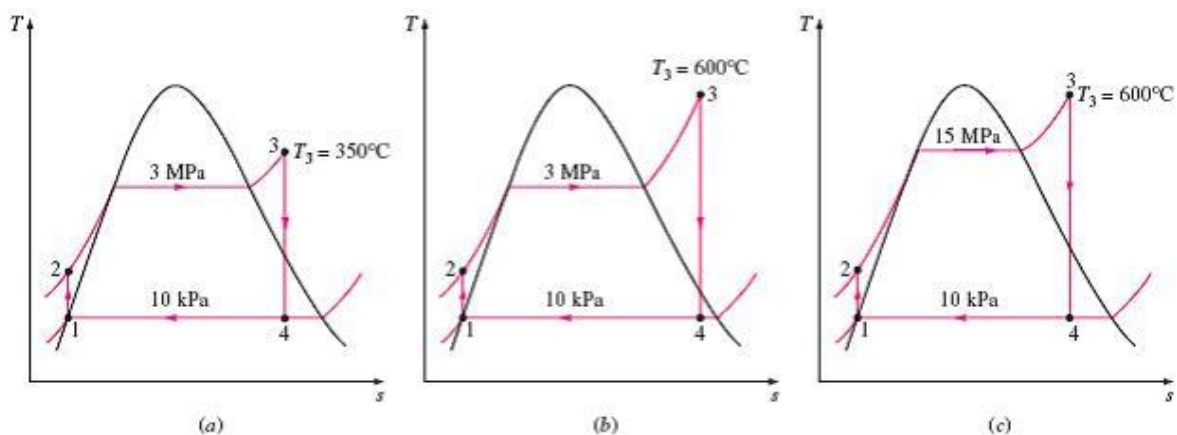

a. From saturated steam tables:

State 1: at $P_1 = 10 \text{ kPa} \rightarrow h_1 = h_f = 191.81 \text{ kJ/kg}, v_1 = v_f = 0.00101 \text{ m}^3/\text{kg}$

State 2: $P_2 = 3 \text{ MPa}$

$$w_{pump} = v_1(P_2 - P_1) = 0.00101 \times (3 \times 10^3 - 10) = 3.02 \text{ kJ/kg}$$

$$w_{pump} = h_2 - h_1 \rightarrow h_2 = h_1 + w_{pump} = 191.81 + 3.02 = 194.83 \text{ kJ/kg}$$

State 3: at $P_3 = 3 \text{ MPa}$ and $T_3 = 350^\circ\text{C}$ from superheated steam tables:

$$h_3 = 3116.1 \text{ kJ/kg} \text{ and } s_3 = 6.745 \text{ kJ/kg} \cdot \text{K}$$

State 4: at $P_4 = 10$ kPa and $s_4 = s_3 = 6.745$ kJ/kg. K

From saturated steam tables: $s_f = 0.6492$ kJ/kg. K, $s_{fg} = 7.4996$ kJ/kg. K

$$h_f = 191.81 \text{ kJ/kg}, h_{fg} = 2392.1 \text{ kJ/kg}$$

$$x_4 = \frac{s_4 - s_f}{s_{fg}} = \frac{6.745 - 0.6492}{7.4996} = 0.8128$$

$$h_4 = h_f + x_4 \cdot h_{fg} = 191.81 + 0.8128 \times 2392.1 = 2136.1 \text{ kJ/kg}$$

$$q_{in} = h_3 - h_2 = 3116.1 - 194.83 = 2921.3 \text{ kJ/kg}$$

$$q_{out} = h_4 - h_1 = 2136.1 - 191.81 = 1944.3 \text{ kJ/kg}$$

$$\eta_{th} = 1 - \frac{q_{out}}{q_{in}} = 1 - \frac{1944.3}{2921.3}$$

$$\eta_{th} = 33.4\% \quad \text{Ans.}$$

b. States 1 and 2 remain the same in this case, and the enthalpies at state 3 (3 MPa and 600°C) and state 4 (10 kPa and $s_4 = s_3$) are determined to be:

$$h_3 = 3682.8 \text{ kJ/kg}$$

$$h_4 = 2380.3 \text{ kJ/kg} (x_4 = 0.915)$$

$$q_{in} = h_3 - h_2 = 3682.8 - 194.83 = 3488 \text{ kJ/kg}$$

$$q_{out} = h_4 - h_1 = 2380.3 - 191.81 = 2188.5 \text{ kJ/kg}$$

$$\eta_{th} = 1 - \frac{q_{out}}{q_{in}} = 1 - \frac{2188.5}{3488}$$

$$\eta_{th} = 37.3\% \quad \text{Ans.}$$

Therefore, the thermal efficiency increases from 33.4% to 37.3% as a result of superheating the steam from 350°C to 600°C. At the same time, the quality of the steam (dryness fraction) increases from 0.813 to 0.915.

c. State 1 remains the same in this case, but the other states change. The enthalpies at state 2 (15 MPa and $s_2 = s_1$), state 3 (15 MPa and 600°C) and state 4 (10 kPa and $s_4 = s_3$) are determined in a similar manner to be:

$$h_2 = 206.95 \text{ kJ/kg}, h_3 = 3583.1 \text{ kJ/kg} \text{ and } h_4 = 2115.3 \text{ kJ/kg} (x_4 = 0.804)$$

$$q_{in} = h_3 - h_2 = 3583.1 - 206.95 = 3376.2 \text{ kJ/kg}$$

$$q_{out} = h_4 - h_1 = 2115.3 - 191.81 = 1923.5 \text{ kJ/kg}$$

$$\eta_{th} = 1 - \frac{q_{out}}{q_{in}} = 1 - \frac{1923.5}{3376.2}$$

$\eta_{th} = 43\%$ **Ans.**

The thermal efficiency increases from 37.3% to 43% as a result of raising the boiler pressure from 3 MPa to 15 MPa while maintaining the turbine inlet temperature at 600°C. At the same time, the quality of the steam decreases from 0.915 to 0.804 (in other words, the moisture content increases from 0.085 to 0.196).

The Ideal Reheat Rankine Cycle

Increasing the boiler pressure increases the thermal efficiency of the Rankine cycle, but it also increases the moisture content of the steam to unacceptable levels. Therefore, the desirable approach is expanding the steam in the turbine in two stages, and reheats it in between. In other words, modify the simple ideal Rankine cycle with a **reheat** process. Reheating is a practical solution to the excessive moisture problem in turbines, and it is commonly used in modern steam power plants.

The figure below explains the (*T-S*) diagram of the ideal reheat Rankine cycle and the schematic of the power plant operating on this cycle. The ideal reheat Rankine cycle differs from the simple ideal Rankine cycle in that the expansion process takes place in two stages. In the first stage (the high-pressure turbine), steam is expanded isentropically to an intermediate pressure and sent back to the boiler where it is reheated at constant pressure, usually to the inlet temperature of the first turbine stage. Steam then expands isentropically in the second stage (low-pressure turbine) to the condenser pressure. Thus the total heat input and the total turbine work output for a reheat cycle become:

$$q_{add} = q_{primary} + q_{reheat} = (h_3 - h_2) + (h_5 - h_4)$$

$$w_{out} = w_{turbine\ 1} + w_{turbine\ 2} = (h_3 - h_4) + (h_5 - h_6)$$

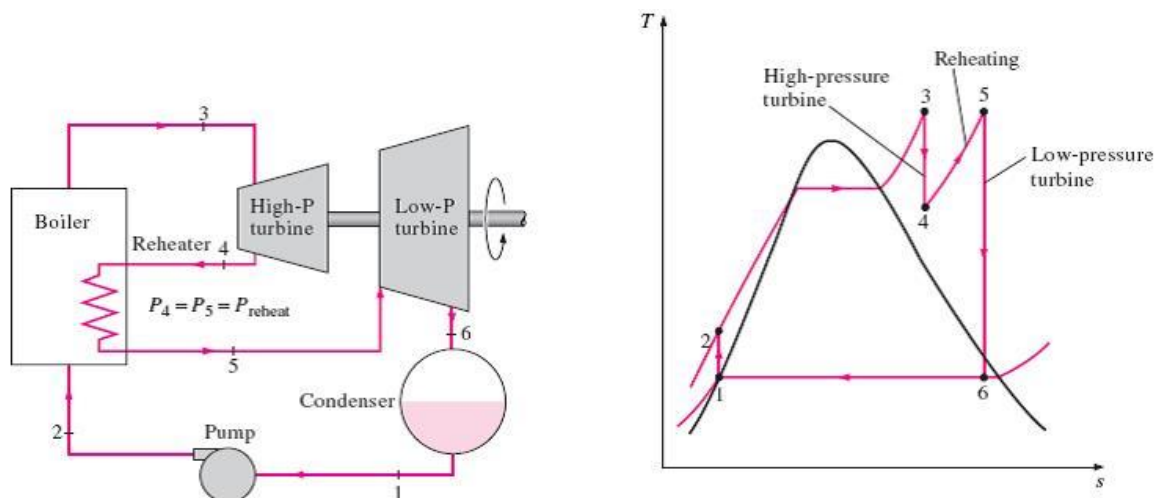

The Ideal Reheat Rankine Cycle

The incorporation of the single reheat in a modern power plant improves the cycle efficiency by 4 to 5 percent by increasing the average temperature at which heat is transferred to the steam.

The reheat temperatures are very close or equal to the turbine inlet temperature. The optimum reheat pressure is about one-fourth of the maximum cycle pressure. For example, the optimum reheat pressure for a cycle with a boiler pressure of 12 MPa is about 3 MPa.

Example (5.4) Consider a steam power plant operating on the ideal reheat Rankine cycle. Steam enters the high-pressure turbine at 15 MPa and 600°C and is condensed in the condenser at a pressure of 10 kPa. If the moisture content of the steam at the exit of the low-pressure turbine is not to exceed 10.4%, determine: (a) the pressure at which the steam should be reheated (b) the thermal efficiency of the cycle. Assume the steam is reheated to the inlet temperature of the high-pressure turbine.

Solution:

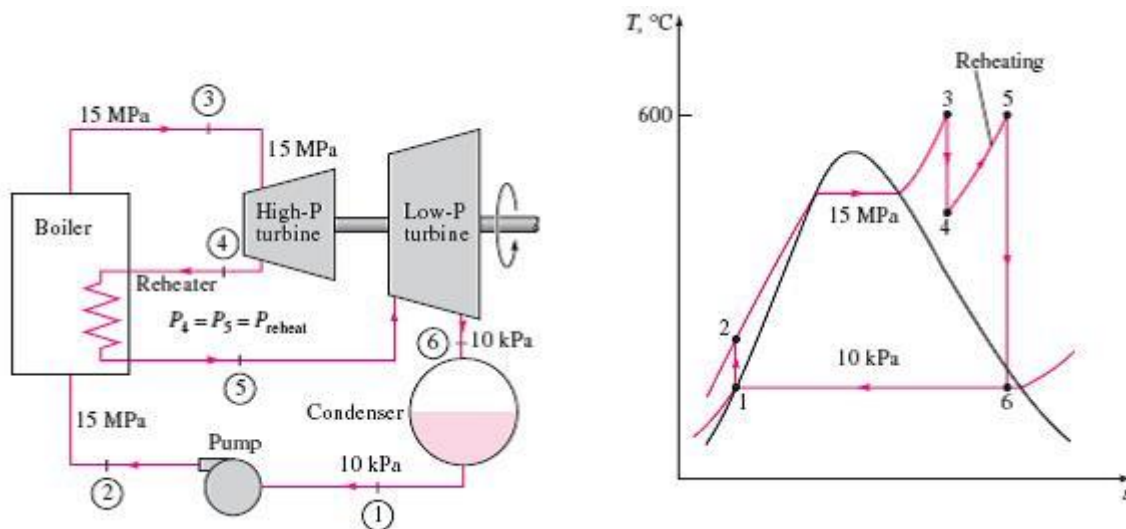

a) State 6: at $P_6 = 10 \text{ kPa}$ and $x_6 = 0.896$

$$s_6 = s_f + x_6 s_{fg} = 0.6492 + 0.896 \times (7.34996) = 7.3688 \text{ kJ/kg.K}$$

$$h_6 = h_f + x_6 h_{fg} = 191.8 + 0.896 \times (2392.1) = 2335.1 \text{ kJ/kg}$$

Thus, $T_5 = 600^\circ\text{C}$ and $s_5 = s_6$

And, $P_5 = 4 \text{ MPa}$ and $h_5 = 3674.9 \text{ kJ/kg}$

So the steam should be reheated at a pressure of 4 MPa to prevent a moisture content greater than 10.4%.

b) The thermal efficiency is calculated as follows:

State 1: at $P_1 = 10 \text{ kPa}$

$$h_1 = h_f = 191.81 \text{ kJ/kg and } v_1 = v_f = 0.00101 \text{ m}^3/\text{kg}$$

State 2: at $P_2 = 15 \text{ MPa}$ and $s_2 = s_1$

$$w_{pump} = v_1(P_2 - P_1) = 0.00101 \times (15 \times 10^3 - 10) = 15.14 \text{ kJ/kg}$$

$$w_{pump} = h_2 - h_1 \rightarrow h_2 = 191.81 + 15.14 = 206.96 \text{ kJ/kg}$$

State 3: at $P_3 = 15 \text{ MPa}$ and $T_3 = 600^\circ\text{C}$

From superheated steam tables: $h_3 = 3583.1 \text{ kJ/kg}$ and $s_3 = 6.6796 \text{ kJ/kg.K}$

State 4: at $P_4 = 4 \text{ MPa}$ and $s_3 = s_4$

From superheated steam tables: $h_4 = 3155 \text{ kJ/kg}$ and $T_4 = 375.5^\circ\text{C}$

$$q_{in} = (h_3 - h_2) + (h_5 - h_4)$$

$$q_{in} = (3583.1 - 206.95) + (3674.9 - 3155.0) = 3896.1 \text{ kJ/kg}$$

$$q_{out} = h_6 - h_1 = 2335.1 - 191.8 = 2143.3 \text{ kJ/kg}$$

$$\eta_{th} = 1 - \frac{q_{out}}{q_{in}} = 1 - \frac{2143.3}{3896.1}$$

$$\eta_{th} = 45\% \quad \text{Ans.}$$

The Regenerative Rankine Cycle

A practical regeneration process in steam power plants is accomplished by extracting or (bleeding) steam from the turbine at various points. This steam, which could have produced more work by expanding further in the turbine, is used to heat the feedwater instead. The device where the feedwater is heated by regeneration is called a **regenerator**, or a **feedwater heater (FWH)**.

Regeneration not only improves cycle efficiency, but also provides a convenient means of deaerating the feedwater (removing the air that leaks in at the condenser) to prevent corrosion in the boiler. It also helps control the large volume flow rate of the steam at the final stages of the turbine (due to the large specific volumes at low pressures). Therefore, regeneration has been used in all modern steam power plants since its introduction in the early 1920s.

A feedwater heater is basically a heat exchanger where heat is transferred from the steam to the feedwater either by mixing the two fluid streams (open feedwater heaters) or without mixing them (closed feedwater heaters). Regeneration with both types of feedwater heaters is discussed below.

1. Open Feedwater Heaters: It is an open (or direct-contact) feedwater heater, it is basically a mixing chamber, where the steam extracted from the turbine mixes with the feedwater exiting the pump. Ideally, the mixture leaves the heater as a **saturated liquid** at the heater pressure. The schematic of a steam power plant with one open feedwater heater (also

called single-stage regenerative cycle) and the (T - S) diagram of the cycle are shown in figure below.

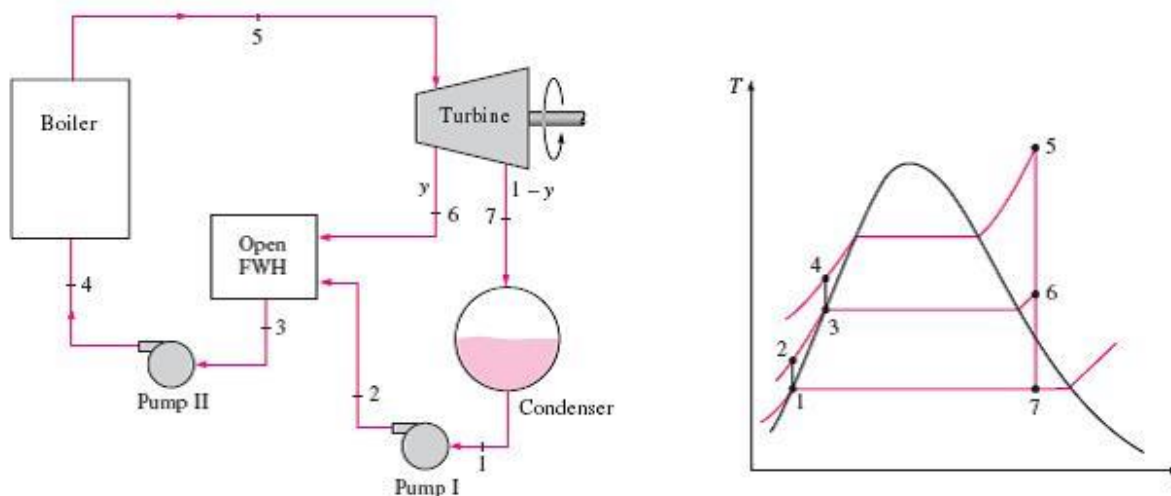

Ideal Rankine Cycle with (Open Feedwater Heater)

In an ideal regenerative Rankine cycle, steam enters the turbine at the boiler pressure (state 5) and expands isentropically to an intermediate pressure (state 6). Some steam is extracted at this state and routed to the feedwater heater, while the remaining steam continues to expand isentropically to the condenser pressure (state 7). This steam leaves the condenser as a saturated liquid at the condenser pressure (state 1). The condensed water, which is also called the feedwater, then enters an isentropic pump, where it is compressed to the feedwater heater pressure (state 2) and is routed to the feedwater heater, where it mixes with the steam extracted from the turbine. The fraction of the steam extracted is such that the mixture leaves the heater as a saturated liquid at the heater pressure (state 3). A second pump raises the pressure of the water to the boiler pressure (state 4). The cycle is completed by heating the water in the boiler to the turbine inlet state (state 5).

In the analysis of steam power plants, it is more convenient to work with quantities expressed per unit mass of the steam flowing through the boiler. For each 1 kg of steam leaving the boiler, (y) kg expands partially in the turbine and is extracted at state 6. The remaining ($1 - y$) kg expands completely to the condenser pressure. Therefore, the mass flow rates are different in different components. If the mass flow rate through the boiler is m° , for example, it is $(1 - y) \times m^\circ$ through the condenser. This aspect of the regenerative Rankine cycle should be considered in the analysis of the cycle as well as in the interpretation of the areas on the (T - S) diagram. The heat and work interactions of a regenerative Rankine cycle with one feedwater heater can be expressed per unit mass of steam flowing through the boiler as follows:

$$q_{add} = h_5 - h_4$$

$$q_{rej} = (1 - y) \times (h_7 - h_1)$$

$$w_{turbine,out} = (h_5 - h_6) + (1 - y) \times (h_6 - h_7)$$

$$w_{pump,in} = (1 - y) \times w_{pump\ 1} + w_{pump\ 2}$$

$$y = \dot{m}_6 / \dot{m}_5$$

$$w_{pump,I} = v_1(P_2 - P_1) = h_2 - h_1$$

$$w_{pump,II} = v_3(P_4 - P_3) = h_4 - h_3$$

The thermal efficiency of the Rankine cycle increases as a result of regeneration. The cycle efficiency increases further as the number of feedwater heaters is increased. The optimum number of feedwater heaters is determined from economic considerations.

Example (5.5) Consider a steam power plant operating on the ideal regenerative Rankine cycle with one open feedwater heater. Steam enters the turbine at 15 MPa and 600°C and is condensed in the condenser at a pressure of 10 kPa. Some steam leaves the turbine at a pressure of 1.2 MPa and enters the open feedwater heater. Determine the fraction of steam extracted from the turbine and the thermal efficiency of the cycle.

Solution:

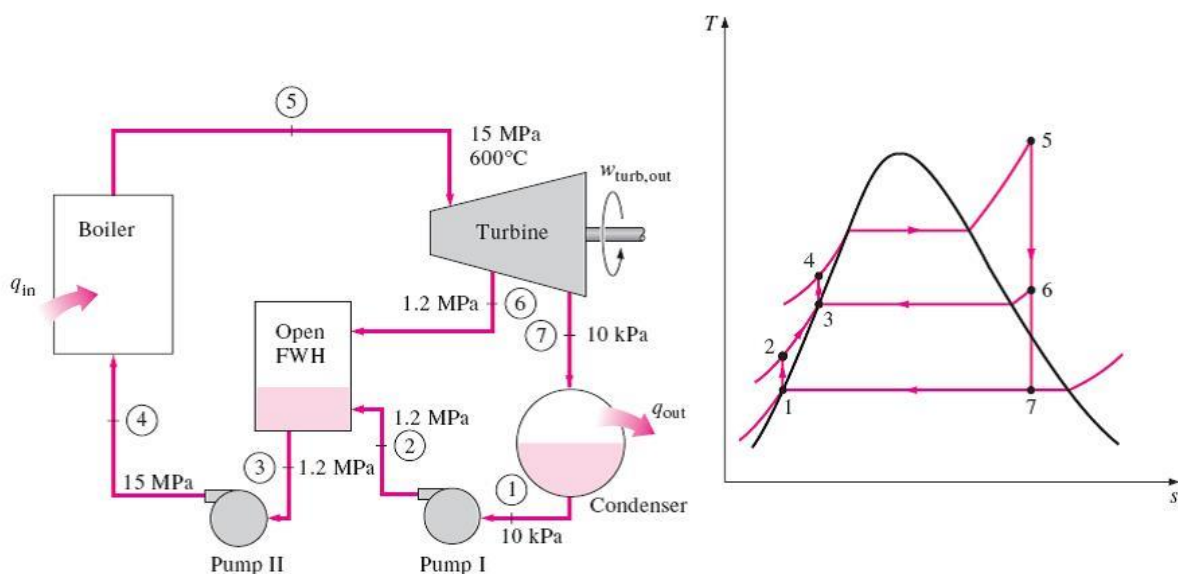

State 1 : at $P_1 = 10$ kPa and saturated liquid:

$$h_1 = h_f = 191.81 \text{ kJ/kg and } v_1 = v_f = 0.00101 \text{ m}^3/\text{kg}$$

State 2: at $P_2 = 1.2$ MPa and $s_2 = s_1$

$$w_{pump,I} = v_1(P_2 - P_1) = 0.00101 \times (1.2 \times 10^3 - 10) = 1.2 \text{ kJ/kg}$$

$$w_{pump,I} = h_2 - h_1 \rightarrow h_2 = 191.81 + 1.2 = 193.01 \text{ kJ/kg}$$

State 3: at $P_3 = 1.2$ MPa and saturated liquid:

$$v_3 = v_f = 0.001138 \text{ m}^3/\text{kg} \text{ and } h_3 = h_f = 798.33 \text{ kJ/kg}$$

$$\text{State 4: at } P_4 = 15 \text{ MPa} \quad \text{and} \quad s_4 = s_3$$

$$w_{pump,II} = v_3(P_4 - P_3) = 0.001138 \times (15 \times 10^3 - 1.2 \times 10^3) = 15.7 \text{ kJ/kg}$$

$$w_{pump,II} = h_4 - h_3 \rightarrow h_4 = 798.33 + 15.7 = 814.03 \text{ kJ/kg}$$

$$\text{State 5: at } P_5 = 15 \text{ MPa} \quad \text{and} \quad T_5 = 600^\circ\text{C}$$

$$\text{Thus, } h_5 = 3583.1 \text{ kJ/kg} \quad \text{and} \quad s_5 = 6.6796 \text{ kJ/kg} \cdot \text{K}$$

$$\text{State 6: } P_6 = 1.2 \text{ MPa} \quad \text{and} \quad s_6 = s_5$$

$$\text{Thus, } h_6 = 2860.2 \text{ kJ/kg} \quad \text{and} \quad T_6 = 218.4^\circ\text{C}$$

$$\text{State 7: } P_7 = 10 \text{ kPa} \quad \text{and} \quad s_7 = s_5$$

$$s_7 = s_f + x_7 \cdot s_{fg} \rightarrow x_7 = \frac{s_7 - s_f}{s_{fg}} = \frac{6.679 - 0.6492}{7.4996} = 0.8041$$

$$h_7 = h_f + x_7 h_{fg} = 191.81 + 0.8041 \times 2392.1 = 2115.3 \text{ kJ/kg}$$

The energy analysis of open feedwater heaters is identical to the energy analysis of mixing chambers. The feedwater heaters are generally well insulated ($Q = 0$), and they do not involve any work interactions ($W = 0$). The energy balance of the feedwater heater is:

$$e_{in} = e_{out} \rightarrow \sum_{in} \dot{m} h = \sum_{out} \dot{m} h$$

$$y \times h_6 + (1 - y) \times h_2 = 1 \times h_3 \rightarrow y = \frac{h_3 - h_2}{h_6 - h_2} = \frac{798.33 - 193.01}{2860.2 - 193.01} = 0.227$$

$$q_{add} = h_5 - h_4 = 3583.1 - 814.03 = 2769.1 \text{ kJ/kg}$$

$$q_{rej} = (1 - y)(h_7 - h_1) = (1 - 0.227) \times (2115.3 - 191.81) = 1486.9 \text{ kJ/kg}$$

$$\eta_{th} = 1 - \frac{q_{rej}}{q_{add}} = 1 - \frac{1486.9}{2769.1}$$

$$\eta_{th} = 46.29\% \quad \text{Ans.}$$

2. Closed Feedwater Heaters: It is another type of feedwater heater used in steam power plants, in which heat is transferred from the extracted steam to the feedwater without any mixing taking place. The two streams now can be at different pressures, since they do not mix. The schematic of a steam power plant with one closed feedwater heater and the (T - S) diagram of the cycle are shown in figure.

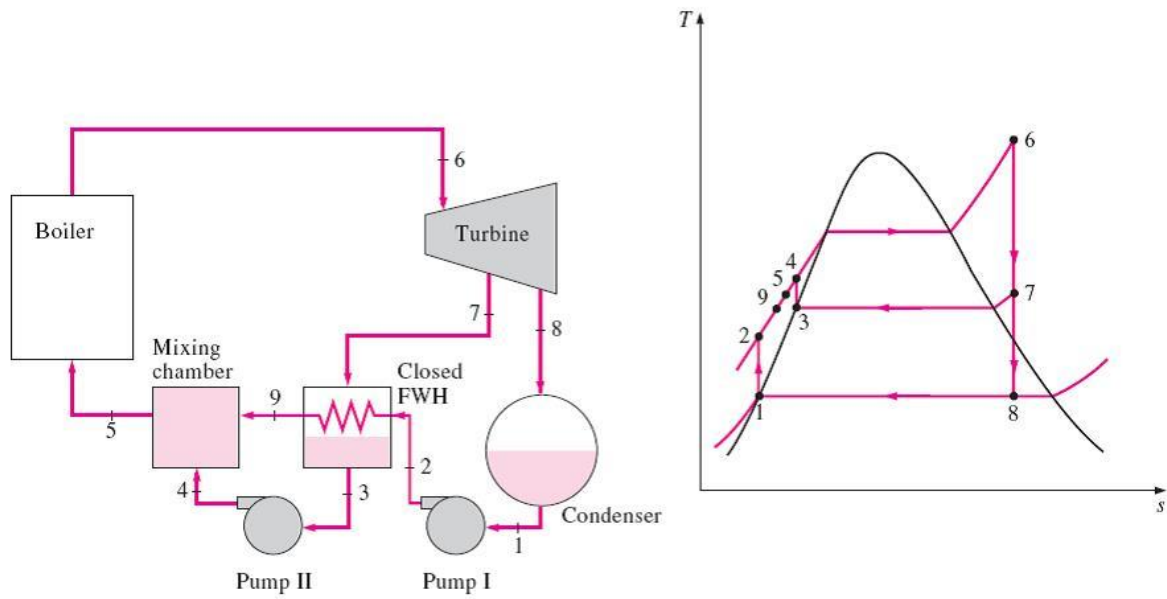

Ideal Rankine Cycle with (Closed Feedwater Heater)

Most steam power plants use a combination of open and closed feedwater heaters or reheating with feedwater heaters.

Exercises

Problem (5.1): Consider a steam power plant that operates on a simple ideal Rankine cycle and has a net power output of 45 MW. Steam enters the turbine at 7 MPa and 500°C and is cooled in the condenser at a pressure of 10 kPa by running cooling water from a lake through the tubes of the condenser. Show the cycle on a (*T-S*) diagram with respect to the saturation lines, and determine (a) the thermal efficiency of the cycle (b) the mass flow rate of the steam.

Ans. (38.9%, 36 kg/s)

Problem (5.2): A steam power plant operates on the reheat Rankine cycle. Steam enters the high-pressure turbine at 12.5 MPa and 550°C at a rate of 7.7 kg/s and leaves at 2 MPa. Steam is then reheated at constant pressure to 450°C before it expands in the low-pressure turbine. The isentropic efficiencies of the turbine and the pump are 85 percent and 90 percent, respectively. Steam leaves the condenser as a saturated liquid. If the moisture content of the steam at the exit of the turbine is not to exceed 5 percent, determine (a) the condenser pressure (b) the net power output (c) the thermal efficiency.

Ans. (9.73 kPa, 10.2 MW, 36.9%)

Problem (5.3): A steam power plant operates on an ideal regenerative Rankine cycle. Steam enters the turbine at 6 MPa and 450°C and is condensed in the condenser at 20 kPa. Steam is extracted from the turbine at 0.4 MPa to heat the feedwater in an open feedwater heater. Water leaves the feedwater heater as a saturated liquid. Show the cycle on a (*T-S*) diagram, and determine (a) the net work output per kilogram of steam flowing through the boiler (b) the thermal efficiency of the cycle.

Ans. (1017 kJ/kg, 37.8%)

Problem (5.4): Consider an ideal steam regenerative Rankine cycle with two feedwater heaters, one closed and one open. Steam enters the turbine at 12.5 MPa and 550°C and exhausts to the condenser at 10 kPa. Steam is extracted from the turbine at 0.8 MPa for the closed feedwater heater and at 0.3 MPa for the open one. The feedwater is heated to the condensation temperature of the extracted steam in the closed feedwater heater. The extracted steam leaves the closed feedwater heater as a saturated liquid, which is subsequently throttled to the open feedwater heater. Show the cycle on a (*T-S*) diagram with respect to saturation lines, and determine (a) the mass flow rate of steam through the boiler for a net power output of 250 MW (b) the thermal efficiency of the cycle.

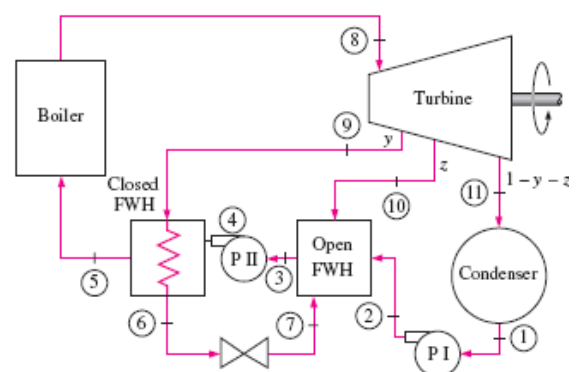

Ans. (200.2 kg/s, 45.4%)

Problem (5.5): Consider a steam power plant that operates on an ideal reheat–regenerative Rankine cycle with one open feedwater heater, one closed feedwater heater and one reheater. Steam enters the turbine at 15 MPa and 600°C and is condensed in the condenser at a pressure of 10 kPa. Some steam is extracted from the turbine at 4 MPa for the closed feedwater heater, and the remaining steam is reheated at the same pressure to 600°C. The extracted steam is completely condensed in the heater and is pumped to 15 MPa before it mixes with the feedwater at the same pressure. Steam for the open feedwater heater is extracted from the low-pressure turbine at a pressure of 0.5 MPa. Determine the fractions of steam extracted from the turbine as well as the thermal efficiency of the cycle.

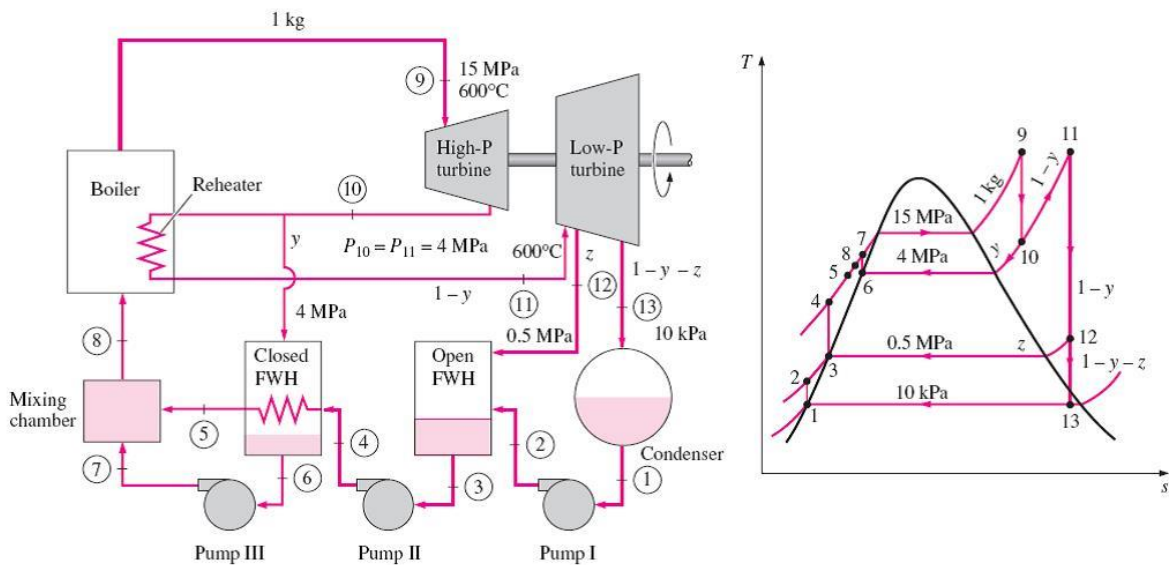

Ans. (0.1766, 0.1306, 49.2%)