



Electromagnetic waves

Lecture 10

Planar equations for electromagnetic waves

Bashaer Abdulhamza

Araa Hassa

Tow stage

**Department of medical physics
Al-Mustaqbal University-College**

Propagation of Uniform Plane Waves

Plane waves are the simplest type of electromagnetic waves, and the properties of these waves are concentrated in how it reflects, breaks, disperses, and loses energy. To find out how a plane wave propagates in a medium. The propagation shown in Figure (10-1) and what determines the distance or proximity of the distance at which the receiver should be.

In order for this to happen, a mathematical equation that describes the movement of wave propagation in the medium of propagation must be known.

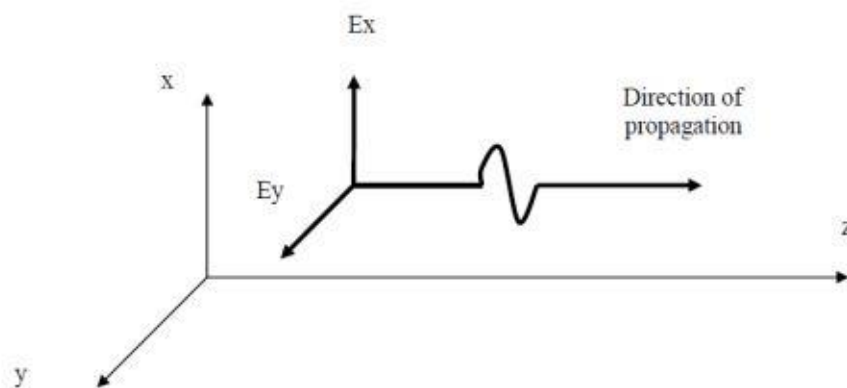

Fig (10-1)

$$\frac{d^2 E_x}{dz^2} - \gamma^2 E_x = 0$$

E_x = electric field component direction X

Z = diffusion direction

γ = propagation constant

By solving the above equation, the electric field can be found as a function of the distance and the propagation constant. Thus, the field can be found electricity at any distance. There is also an equation for the magnetic field that can be solved to find the magnetic field at any distance. By finding the electric and magnetic fields at a specific point, the energy at that point can be calculated.

The propagation constant is of great importance because it determines the following propagation wave:

a - The rate of decay in the wave energy. b - the speed of the wave.

This constant depends on the following:

a- Characteristics of the electrical diffusion medium. b - Frequency of the propagated signal

$$\gamma^2 = -\omega^2 \mu \varepsilon + j\omega \mu \sigma$$

ω = The angular frequency of the wave

$$\omega = 2\pi f$$

f= wave frequency

ε = permittivity of the diffusion medium

μ = permeability of the diffusion medium

σ = conductivity of the diffusion medium

j= The negative root of a single number

$$\gamma = \alpha + j\beta$$

α = wave decay constant

β = phase constant of the wave

The decay constant gives and shows the loss of energy in the wave during its propagation.

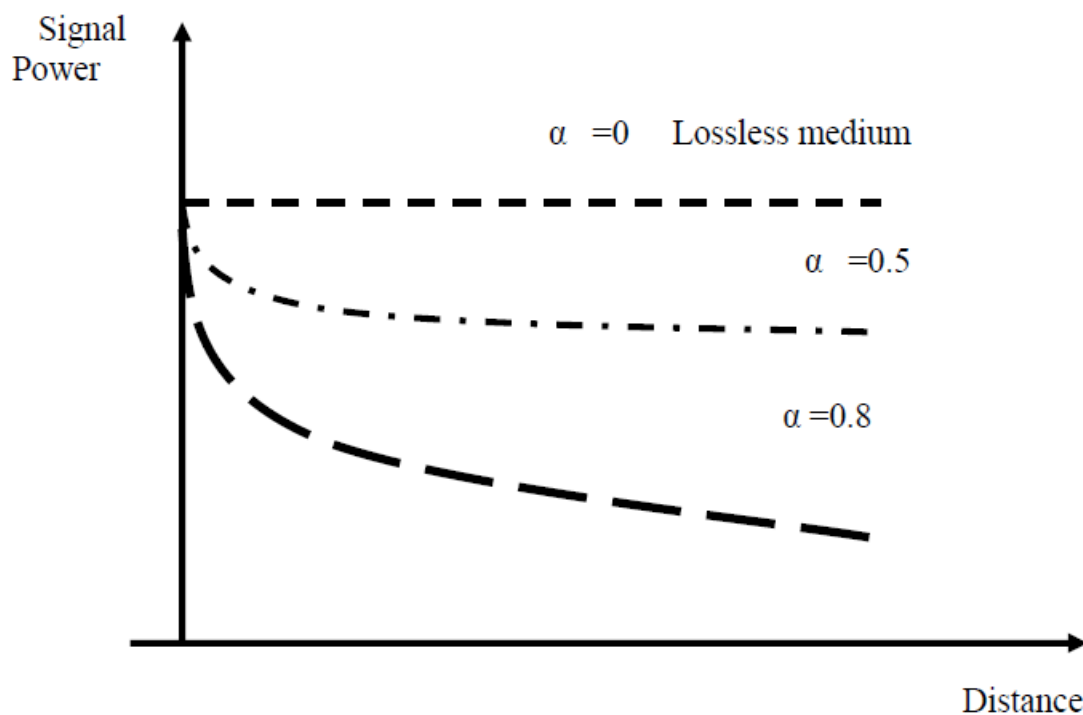

Fig (10-2)

Finger (10-2) The wave energy changes with the change in the value of the decay constant.

From the phase constant β , the wave velocity can be calculated from the following relations

$$v_{ph} = \omega / \beta$$

$$v_g = \partial \omega / \partial \beta$$

v_{ph} = phase speed

v_g = group speed

The phase velocity represents the wave velocity if the medium is not lossy, but if it is lossy, the wave velocity is set by group velocity.

***The impedance of the propagating medium of the electromagnetic wave is calculated by the following relation**

$$Z = \frac{E_x}{H_y} = \sqrt{\frac{j\omega\mu}{\sigma + j\omega\epsilon}}$$

The impedance depends on the properties of the electrical propagating medium and the frequency of the propagating signal.

***The propagation in lossless media $\sigma = 0$**

$$\gamma^2 = -\omega^2 \mu \epsilon + j\omega \mu \sigma$$

$$\gamma^2 = -\omega^2 \mu \epsilon + 0$$

$$\gamma = \sqrt{-\omega^2 \mu \epsilon}$$

$$\gamma = j \omega \sqrt{\mu \epsilon}$$

$$\gamma = \alpha + j \beta$$

$$\alpha = 0$$

$$\beta = \omega \sqrt{\mu \epsilon}$$

$$v_{ph} = v_g = \frac{1}{\sqrt{\epsilon_0 \mu_0}} = 3 \times 10^8 \text{ m/sec}$$

$$Z = \frac{E_x}{H_y} = \sqrt{\frac{j\omega\mu}{\sigma + j\omega\epsilon}} = \sqrt{\frac{\mu_0}{\epsilon_0}} = 120\pi = 377\Omega$$

Example: A regular plane electromagnetic wave propagating in a lossless medium with a relative permeability coefficient of 4 and a relative permittivity coefficient of one. Find: 1- decay constant 2- phase constant 3- phase velocity 4- velocity the group.

$$1- \alpha=0$$

$$2- \beta = \omega \sqrt{\mu \epsilon}$$

$$3- v_{ph} = \frac{\omega}{\beta} = \frac{1}{\sqrt{\mu \epsilon}} = \frac{1}{\sqrt{\mu_r \mu_0 \epsilon_r \epsilon_0}}$$

$$= 1/\sqrt{4 \times 8.85 \times 10^{-8} \times 1 \times 4\pi 10^{-7}}$$

$$= 3 \times 10^8 / 2 \text{ m/sec}$$

اي ان سرعة الموجة في هذا الوسط تساوي نصف سرعة الضوء.

$$4- Z = \sqrt{\frac{j\omega\mu}{\sigma + j\omega\epsilon}} = \sqrt{\frac{\mu}{\epsilon}} = \sqrt{\frac{\mu_r \mu_0}{\epsilon_0 \epsilon_r}} = \sqrt{\frac{1 \times 4\pi 10^{-7}}{4 \times (\frac{1}{36\pi}) 10^{-9}}} = 120\pi/2$$

From this it is clear that the impedance of the medium to the wave has become half the impedance of the lossless vacuum of this wave.

* Orthogonal incidence of uniform plane waves on flat surfaces

When electromagnetic waves fall from one medium to another that differs in electrical properties, these Waves may suffer from reflection or refraction and scattering.

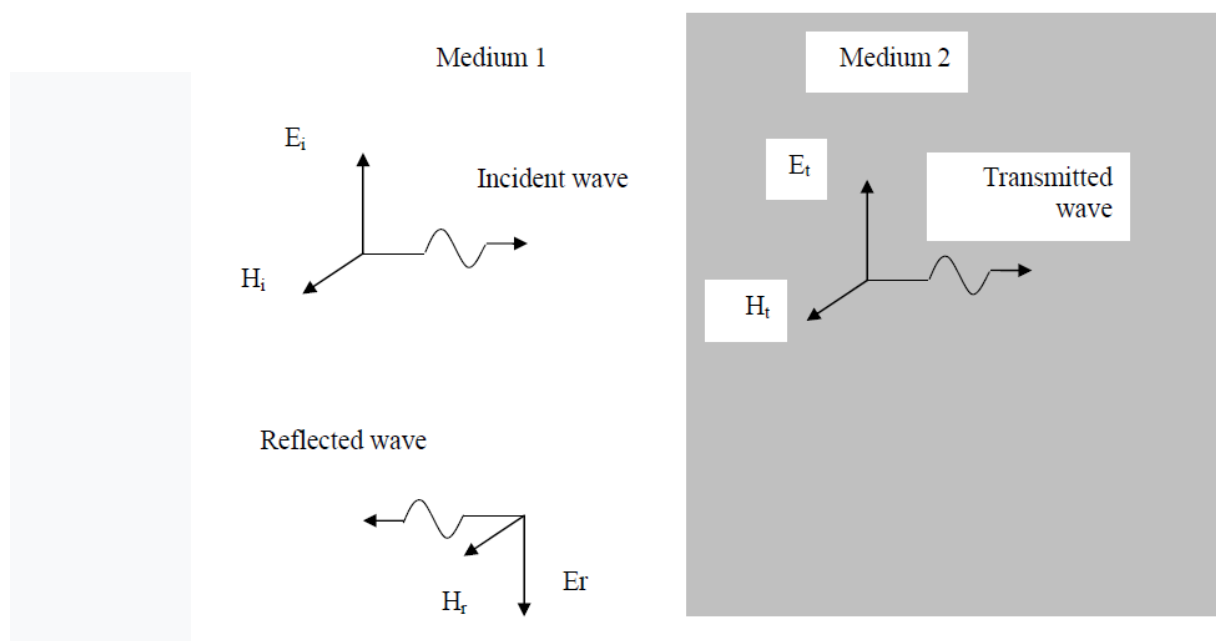

To set the value of Refracted Waves and Reflected Waves, it is necessary first Determine the value of incident waves, and this is done by solving the wave equation

$$\frac{d^2 E_x}{dz^2} - \gamma^2 E_x = 0$$

$$E_x = E_m^+ e^{-\gamma z} + E_m^- e^{+\gamma z}$$

The first part of the previous equation is called the forward wave, which propagates in the direction positive in the Z direction. The second part is called the Backward wave, which propagates in the direction The negative of the Z direction. We will be satisfied with the first part of the previous equation

$$H_i = H_m^+ e^{-\gamma z} a_y$$

$$H_i = H_m^+ e^{-\alpha z} e^{-\beta z} a_y$$

$$H_i = \frac{E_i}{Z_1}$$

$$E_r = E_m^+ e^{-\gamma z} a_x$$

$$E_r = E_m^+ e^{-\alpha z} e^{-\beta z} a_x$$

$$H_r = H_m^+ e^{-\gamma z} a_y$$

$$H_r = H_m^+ e^{-\alpha z} e^{-\beta z} a_y$$

$$H_r = \frac{E_r}{Z_1}$$

$$E_t = E_t^+ e^{-\gamma z} a_x$$

$$E_t = E_t^+ e^{-\alpha z} e^{-\beta z} a_x$$

$$H_r = H_t^+ e^{-\gamma z} a_y$$

$$H_r = H_t^+ e^{-\alpha z} e^{-\beta z} a_y$$

$$H_r = \frac{E_t}{Z_2}$$

From these relationships the reflection index and refractive index can be deduced.

Reflection coefficient: It is determined by the relationship between the reflected wave and the incident wave

$$\Gamma = \frac{E_r}{E_i} = \frac{Z_2 - Z_1}{Z_2 + Z_1}$$

Transmission coefficient: It is determined by the relationship between the transmitted wave and the incident wave

$$T = \frac{E_t}{E_i} = \frac{2Z_2}{Z_2 + Z_1}$$

From the previous relations, it is clear that when the reflection coefficient is equal to one, the transmission coefficient is equal to zero and vice versa, the relationship between these two factors is:

$$\Gamma + T = 1$$

Example 1: A plane electromagnetic wave with a value of 100 V/m falls vertically from a vacuum onto another medium that has a surface.

A plane with an impedance of 70 Ω Find: 1- the reflection coefficient

2- the transmission coefficient 3- the value of the reflected wave 4

The value of the refracted wave 5- The condition at which total reflection occurs 6- The condition at which total transmission occurs.

$$1- \Gamma = \frac{E_r}{E_i} = \frac{Z_2 - Z_1}{Z_2 + Z_1}$$

$$= \frac{70 - 377}{70 + 377} = -0.69$$

$$\Gamma + T = 0.69 + 0.31 = 1$$

$$E_r + E_t = 69 + 31 = 100 = E_i$$

$$E_t = E_i - E_r = 100 - 69 = 31 \text{ V/m}$$

$$5- Z_2 = 0$$

$$6- Z_1 = Z_2$$

$$2- T = \frac{E_t}{E_i} = \frac{2Z_2}{Z_2 + Z_1}$$

$$= \frac{2 \times 70}{70 + 377} = 0.31$$

$$3- \Gamma = \frac{E_r}{E_i}$$

$$-0.69 = \frac{E_r}{100}$$

$$E_r = -69 \text{ V/m}$$

$$4- T = \frac{E_t}{E_i}$$

$$0.31 = \frac{E_t}{100}$$

$$E_t = 31 \text{ V/m}$$

Homework

A plane electromagnetic wave with a value of 100 V/m falls vertically from a vacuum onto another medium that has a surface. A plane with an impedance equal to 300Ω - find:

- 1- the reflection coefficient
- 2- the transmission coefficient
- 3- the value of the reflected wave
- 4-The value of the refracted wave.