



Refrigeration and Air conditioning Engineering.

3rd year – refrigeration and Air conditioning Course

M.Sc. Zahraa F. Hussain



Pumps selection part 1

Lecture -17-

M.Sc. Zahraa F. Hussain

Msc. Zahraa F. Hussain



Msc. Zahraa F. Hussain



Pumps

- Pumps are required to transport the required fluid at a given mass flow rate around a system against the resistance to flow.
- Centrifugal pumps are normally used for most building services applications.
- There are other types of pumps, such as positive displacement pumps, that are normally used in applications where high viscosity fluid is the system medium, such as heavy fuel oil.



- configured with the suction and discharge connections are in line. Opposed to end suction pumps that require a change in direction. In-line pumps are often used in situations where fluid just needs to be pressurized to a higher pressure.



- The two main designs of pumps that are used in building services are the in-line pump

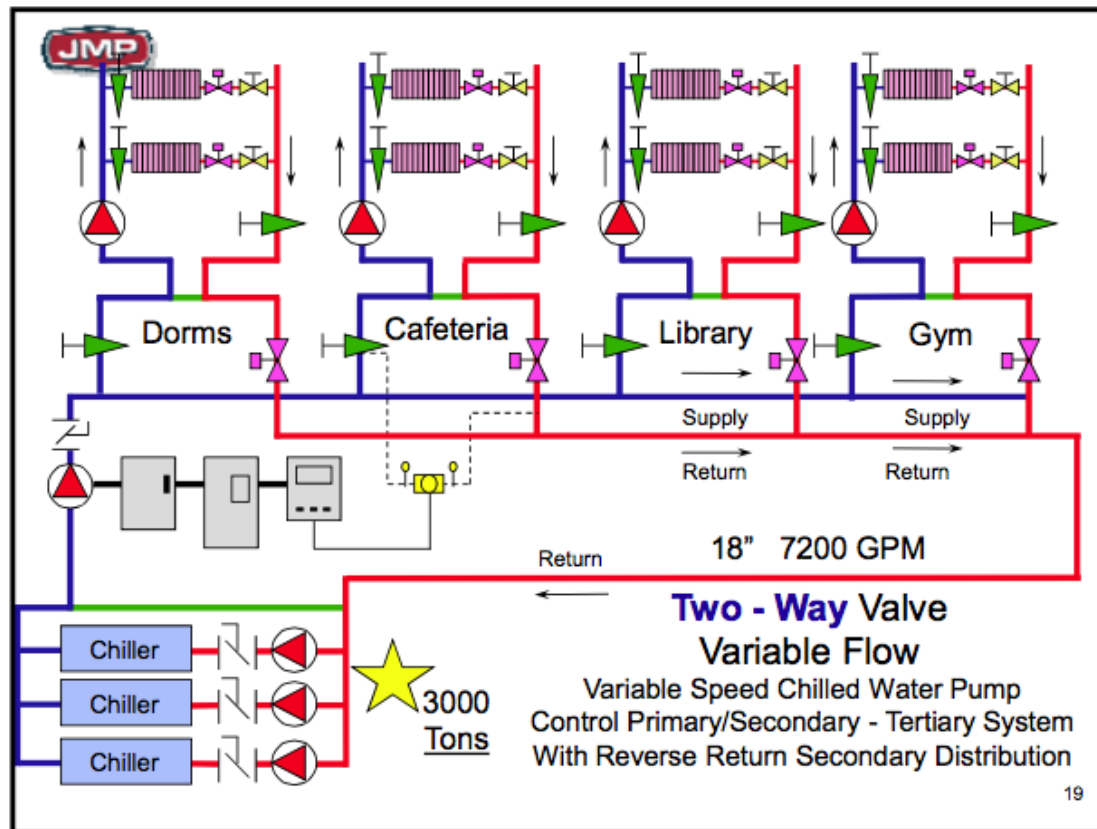

and the end-suction pump.

- A type of centrifugal pump that has a casing with the suction coming in one end and the discharge coming out the top. They are almost always

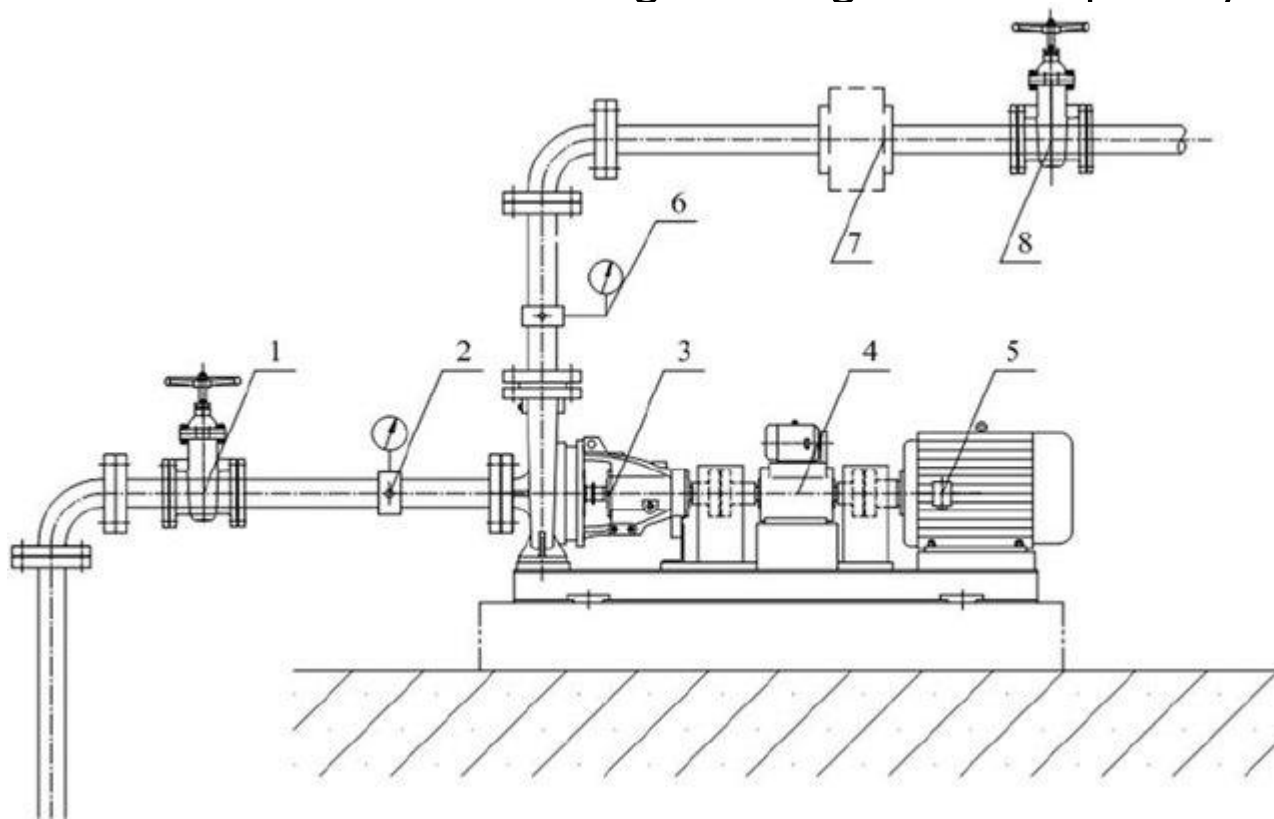

r.



- **The basic information required to size a pump are:**
- 1- the total mass flow rate required for the system
- 2- the total pressure drop (the index pressure drop).



- The centrifugal pump creates an increase in pressure by transferring mechanical energy from the motor to the fluid through the rotating impeller.
- The fluid flows from the inlet to the impeller center and out along its blades.
- The centrifugal force hereby increases the fluid velocity and consequently also the kinetic energy is transformed to pressure. Figure 1 shows an example of the fluid path through the centrifugal pump.

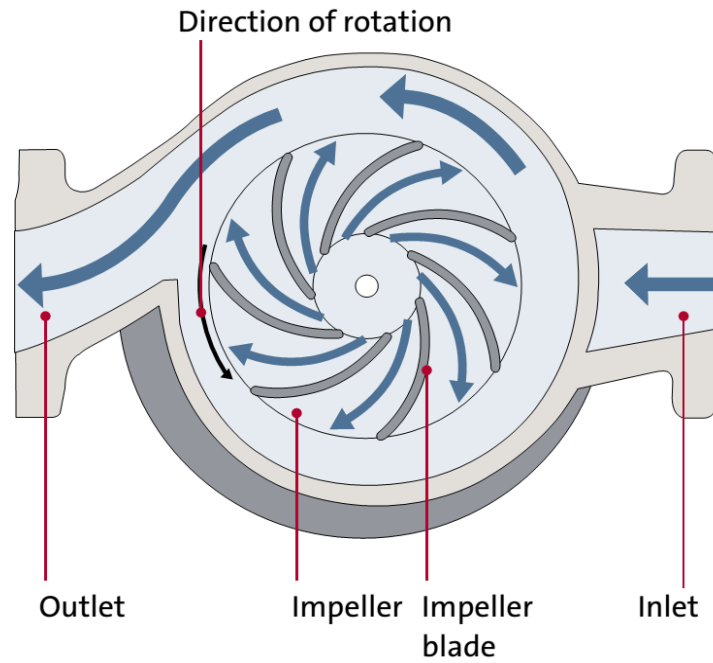



CENTRIFUGAL PUMPS



www.LearnEngineering.org



The blades of the rotating impeller transfer energy to the fluid there by increasing pressure and velocity. The fluid is sucked into the impeller at the impeller eye and flows through the impeller channels formed by the blades between the shroud and hub, see figure 2.



The impeller's direction of rotation

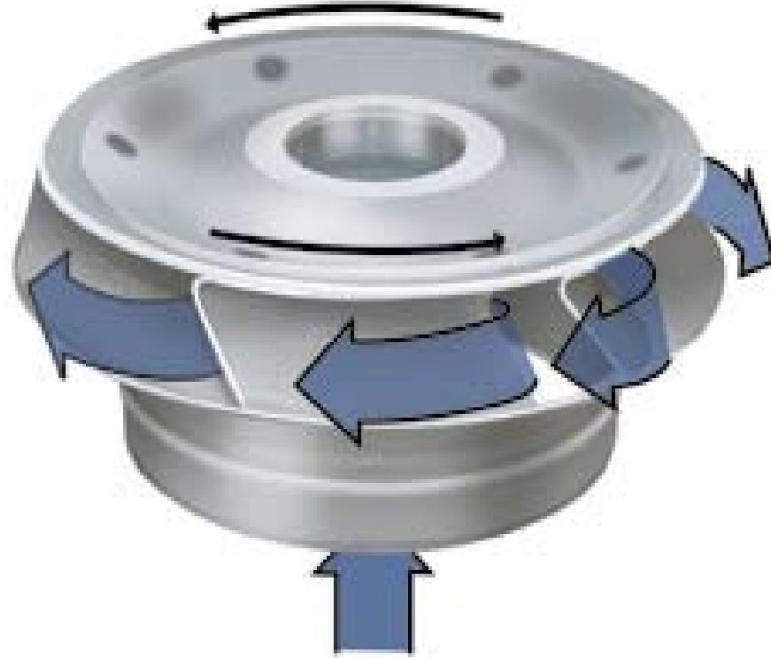



- The impeller is usually driven by an electric motor. The coupling between motor and hydraulics is a weak point because it is difficult to seal a rotating shaft. In connection with the coupling, distinction is made between two types of pumps. See Fig. 3

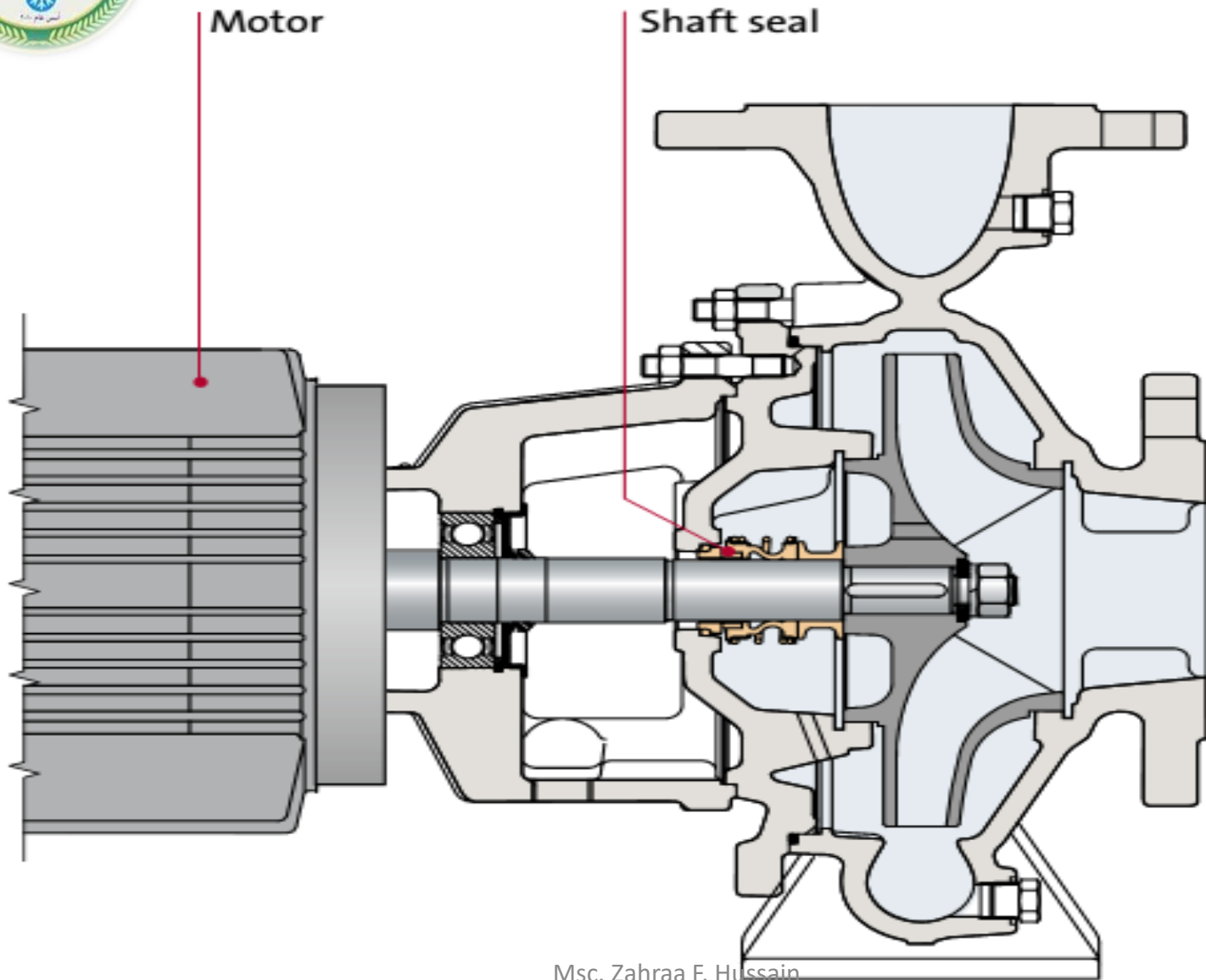



5-2 System characteristics:

- The system performance can be expressed in the form of the equation

$$\Delta p = R \cdot Q^2$$

- The constant R is required as the equation is derived from $p \propto Q^2$. Most building services systems will use the turbulent flow equation



- Any system will have a resistance to flow due to the fittings, components, (such as heat exchangers) and the materials used.
- The flow of fluid through a system will vary according to the pressure developed by the pump. Fig 4 shows the system characteristic on a pressure and volume flow rate graph.

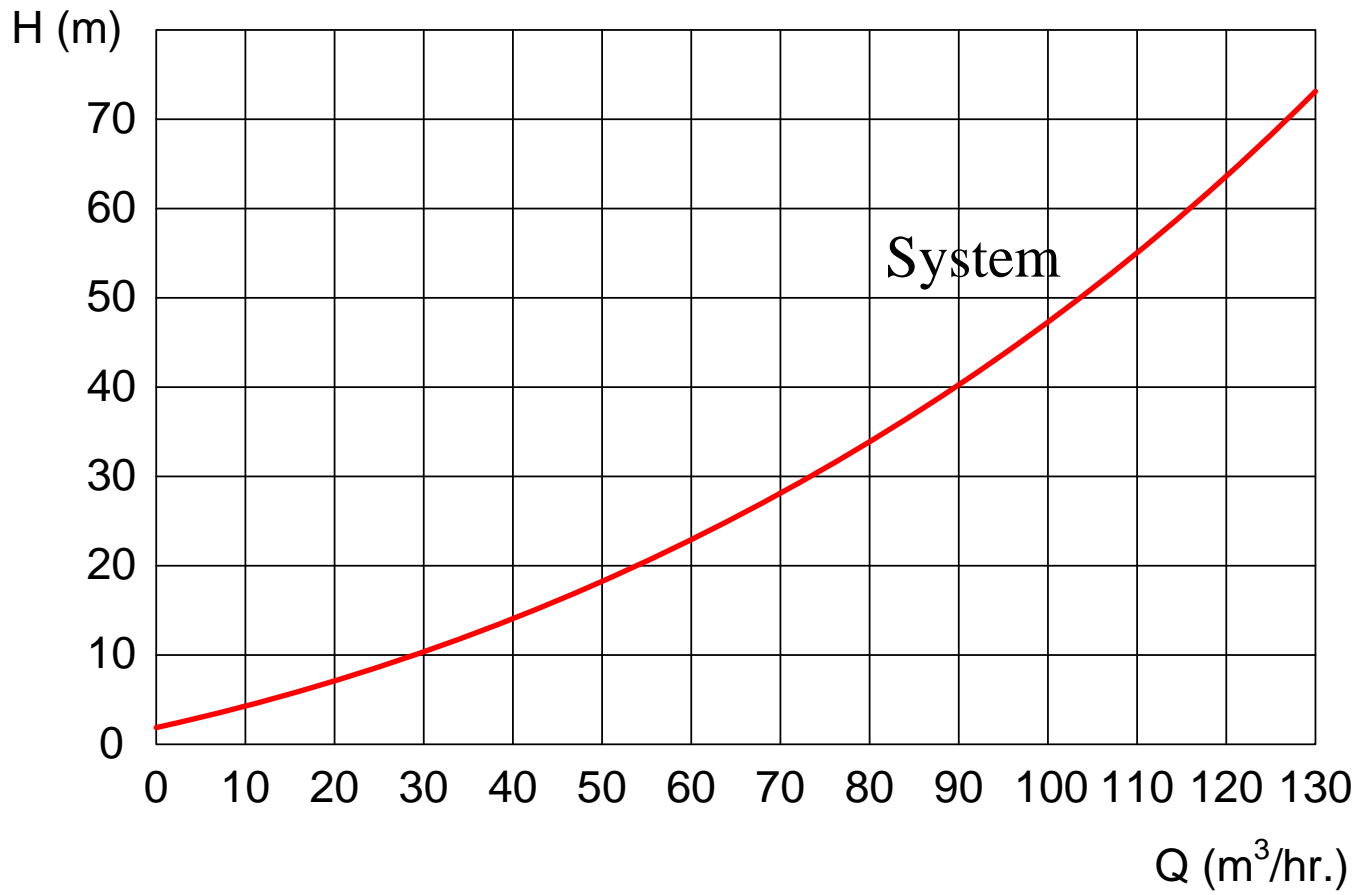



Pump performance curve

- The pump performance is normally described by a set of curves. As follows:
- **Standard curves:**
- Performance curves are used by the customer to select pump matching his requirements for a given application. The data sheet contains information about the head (H) at different flows (Q), see figure 4. The requirements for head and flow determine the overall dimensions of the pump.

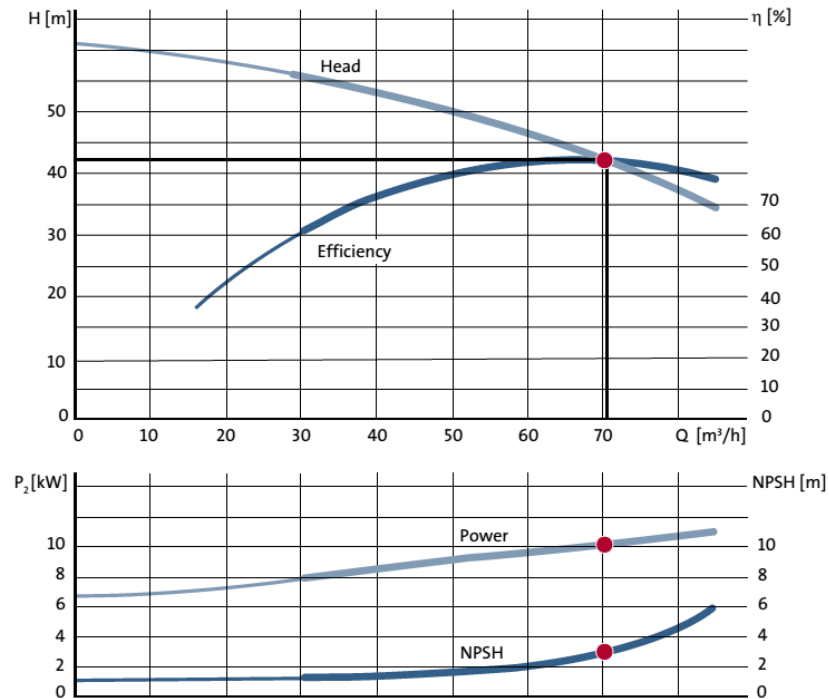

- Fig. 5 Typical performance curves for a centrifugal pump. Head (H), power consumption (P), efficiency (η) and **Net Positive Suction Head (NPSH)** are shown as function of the flow.



Pressure

- Pressure (p_t) is an expression of force per unit area and is split into static and dynamic pressure. The sum of the two pressures is the total pressure:
- $p_t = p_s + p_{dyn.}$
- p_s : Static pressure (Pa.)
- $p_{dyn.}$: Dynamic pressure (Pa.)



- Static pressure is measured with a pressure gauge, and the measurement of static pressure must always be done in static fluid or through a pressure tap mounted perpendicular to the flow direction, as shown in Fig. 5-a .

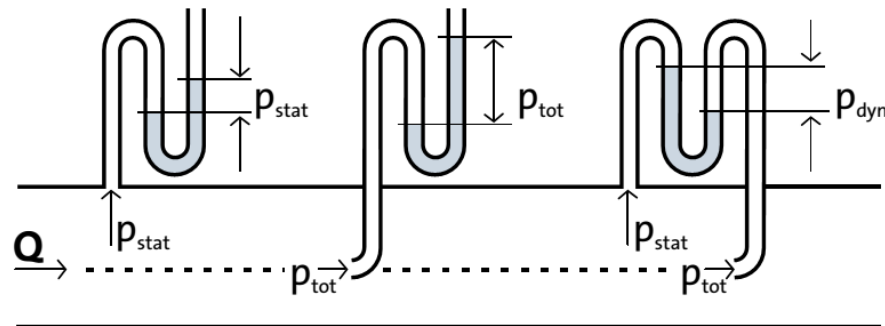



- Total pressure can be measured through a pressure tap with the opening facing the flow direction, see figure 5-a.
- The dynamic pressure can be found measuring the pressure difference between total pressure and static pressure.
- Such a combined pressure measurement can be performed using a pitot tube.



- Dynamic pressure is a function of the fluid velocity. The dynamic pressure can be calculated with the following formula, Where the velocity (C) is measured and the fluid density (ρ) is know:

- $$p_{dyn.} = \frac{1}{2} \rho \cdot C^2$$

- ρ : Liquid density (kg/m^3)
- C : Liquid velocity (m/s)



- Dynamic pressure can be transformed to static pressure and vice versa.
- Flow through a pipe where the pipe diameter is increased converts dynamic pressure to static pressure, see figure 6.
- The flow through a pipe is called a pipe flow, and the part of the pipe where the diameter is increasing is called a diffuser.

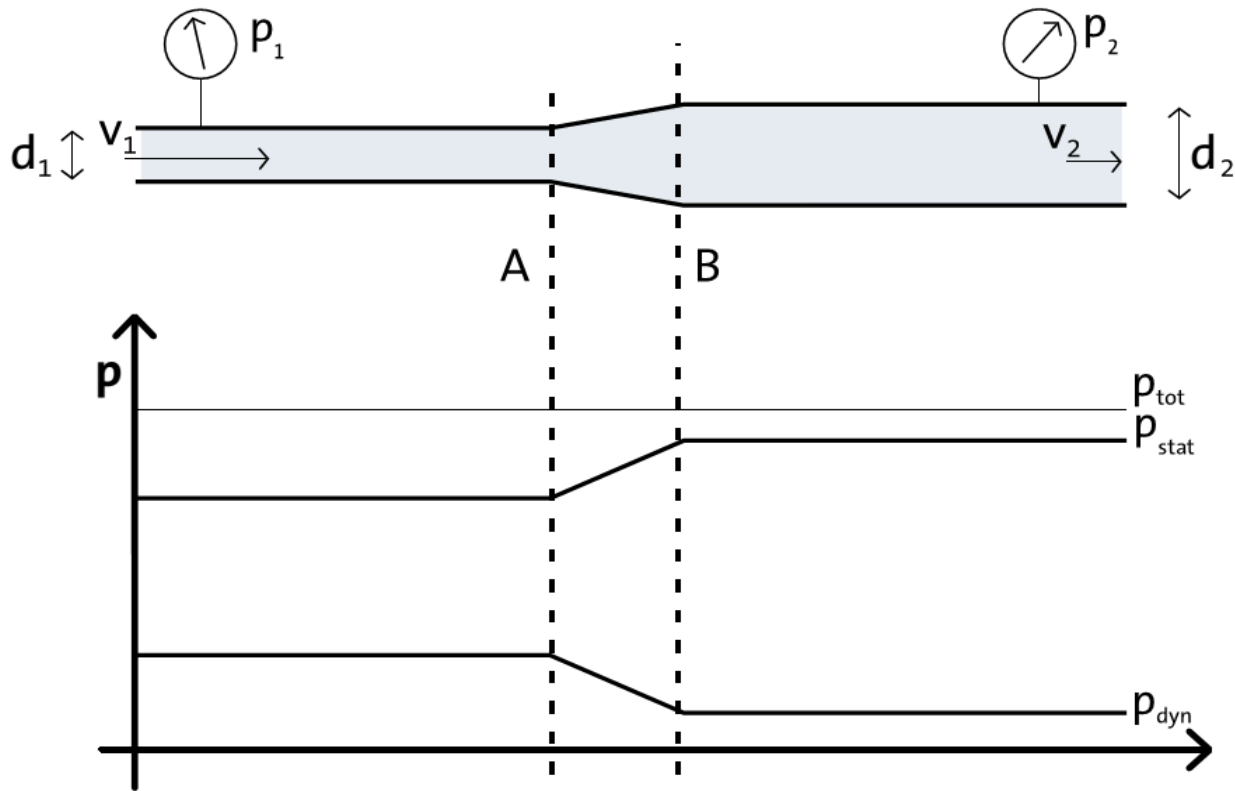



Absolute and gauge pressure

- Pressure is defined in two different ways: absolute pressure or gauge pressure.
- **Absolute pressure** refers to the absolute zero, and absolute pressure can thus only be a positive number.
- **gauge** refers to the pressure of the surroundings. A positive gauge pressure means that the pressure is above the barometric pressure, and a negative relative pressure means that the pressure is below the barometric pressure.



- The atmospheric pressure is measured as absolute pressure. The atmospheric pressure is affected by the weather and altitude.
- The conversion from relative pressure to absolute pressure is done by adding the current gauge pressure to the measured relative pressure
- $p_{abs} = p_g + p_a.$



Head

- A volume flow rate (Q) and head pressure (H) curve or pump curve shows the head as a function of the flow.
- The flow (Q) is the rate of fluid going through the pump. The flow is generally stated in cubic meter per hour [m^3/h] but at insertion into formulas cubic meter per second [m^3/s] is used.
- Fig. 7 shows a typical Q-H curve. The Q-H curve for a given pump can be determined using by run the pump with constant speed.
- Q equals 0 and H reaches its highest value when the valve is completely closed.
- The valve is gradually opened and as Q increases H decreases.

Graph 2

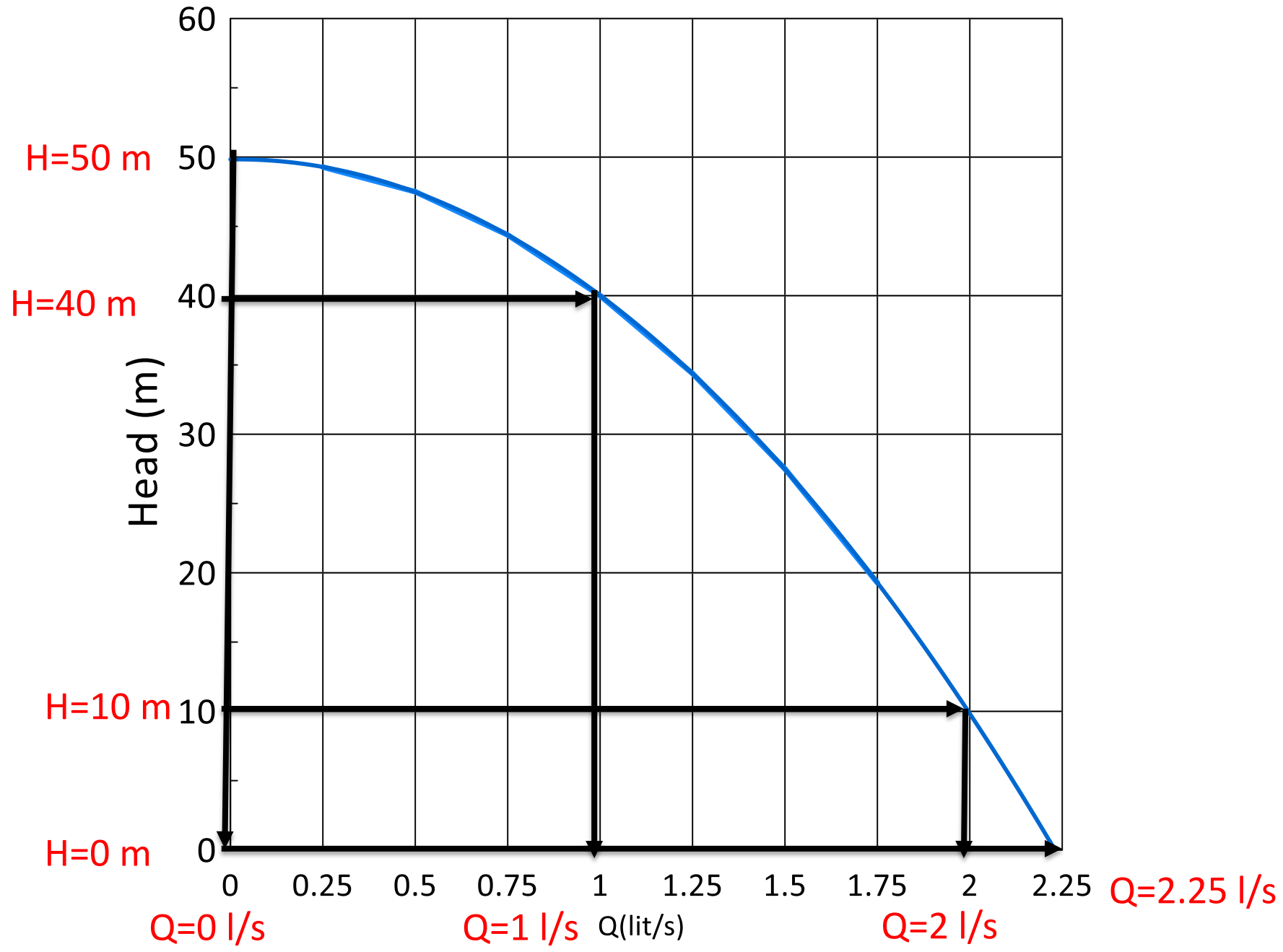



- H is the height of the fluid column in the open pipe after the pump.
- The Q-H curve is a series of coherent values of Q and H represented by the curve shown in figure 7.
- In most cases the differential pressure across the pump Δp_t is measured and the head H is calculated by the following formula:
- $$H = \frac{\Delta p_t}{\rho \cdot g}$$



Hydraulic power

- The hydraulic power P_{hyd} is the power transferred from the pump to the fluid. As seen from the following formula, the hydraulic power is calculated based on flow, head and density:
- $$P_{hyd} = \Delta p_t \cdot Q$$



Efficiency

- The total efficiency (η_{tot}) is the ratio between hydraulic power and supplied power

- $$\eta_{tot} = \frac{P_{hyd}}{P}$$



Pumps operating in systems

- A pump is always connected to a system where it must circulate or lift fluid.
- The energy added to the fluid by the pump is partly lost as friction in the pipe system or used to increase the head.



- If several pumps are combined in the same application, **the pump curve for the system can be found by adding up the pumps' curves** either serial or parallel. Regulated pumps adjust to the system by changing the rotational speed.
- The regulation of speed is especially used in **heating systems** where the need for heat depends on the ambient temperature, and in **water supply systems** where the demand for water varies with the consumer opening and closing the tap.



Single pump in a system:

- A system characteristic is described by a parabola due to an increase in friction loss related to the flow squared. $\Delta p \propto Q^2$
- The system characteristic is described by a steep parabola if the resistance in the system is high.

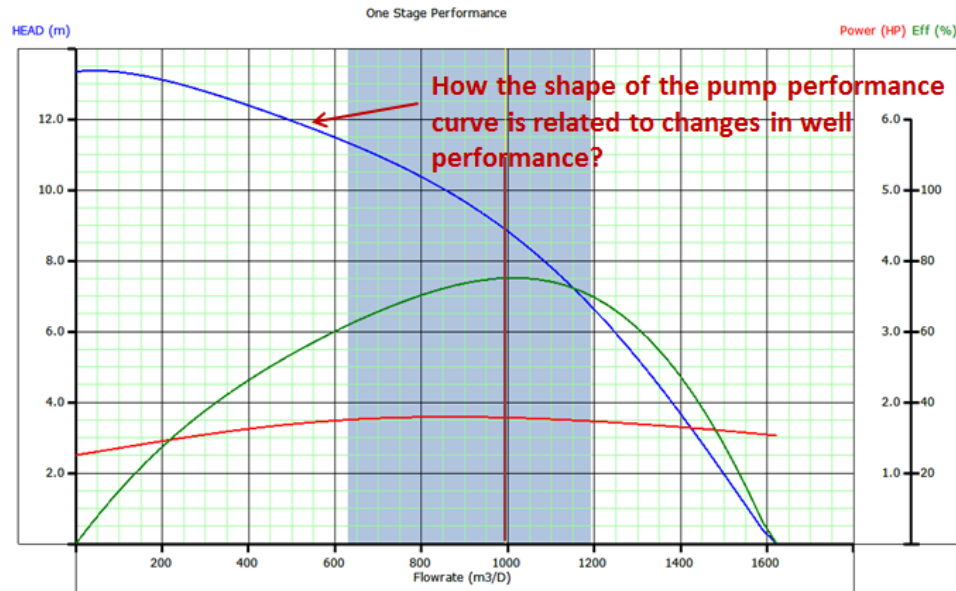



Single pump in a system:



- The parabola flattens when the resistance decreases. Changing the settings of the valves in the system changes the characteristics.

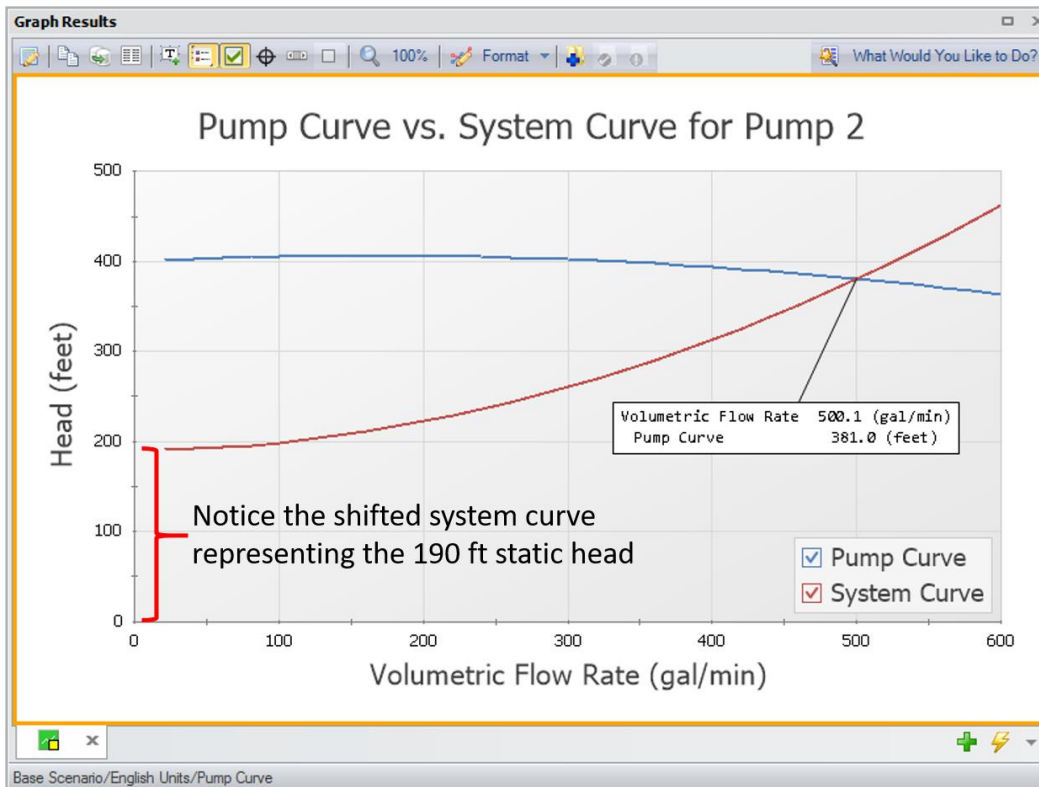



- The operating point is found where the curve of the pump and the system characteristic intersect.
- In closed systems, see figure 5, there is no head when the system is not operating. In this case the system characteristics of a closed system resembles a parabola starting at point (0.0)

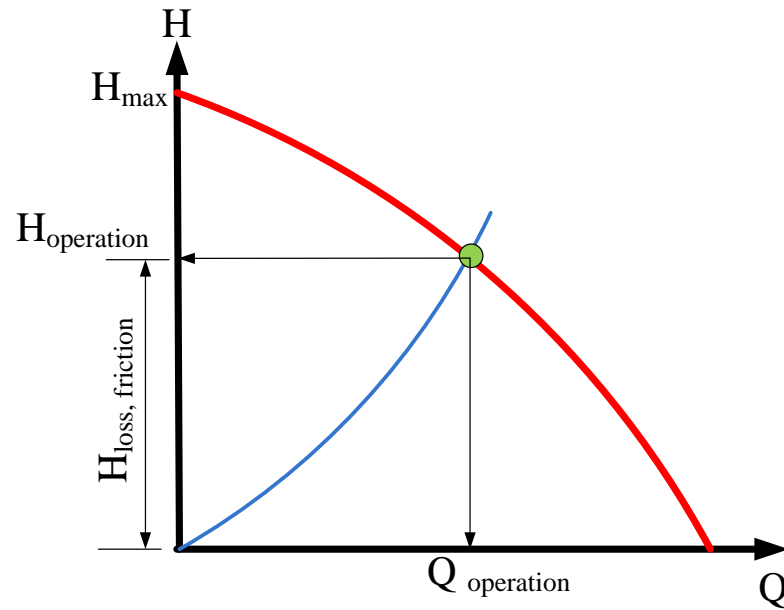
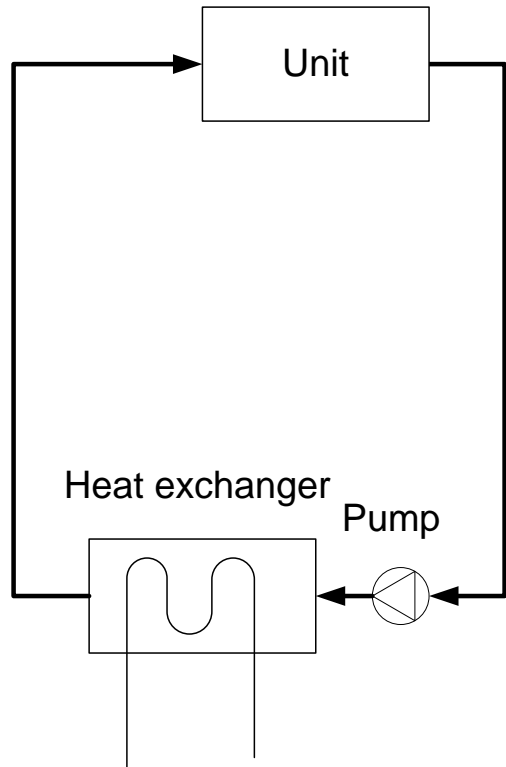

- Fig. 5 Closed system operation curve



- In systems where water is to be moved from one level to another, see figure 6, there is a constant pressure difference between the two reservoirs, corresponding to the height difference.
- This causes an additional head which the pump must overcome. In this case the system characteristics goes through $(0, H_z)$ instead of $(0, 0)$.

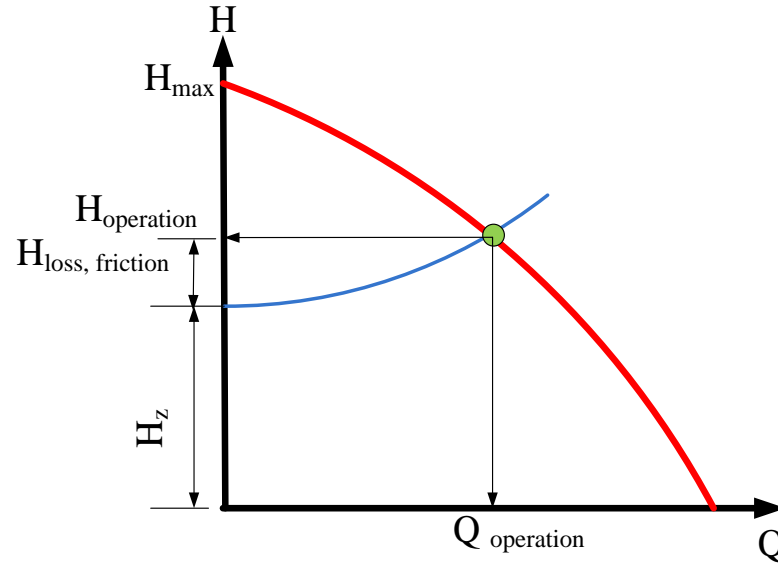
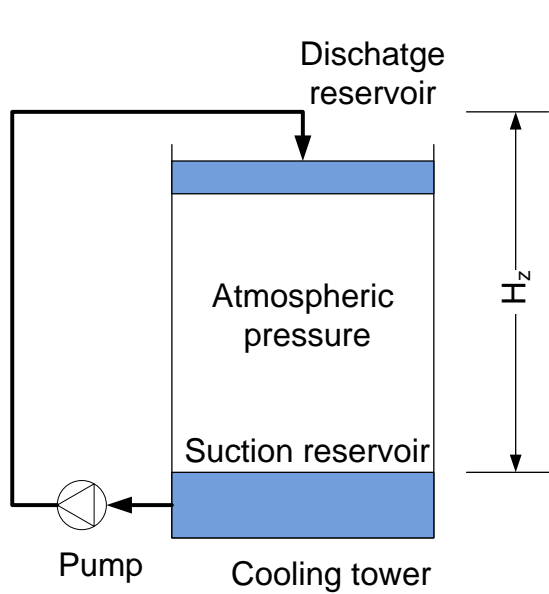

- Open system operation curve



Pumps operated in parallel

- In systems with **large variations in flow** and a **request for constant pressure**, two or more pumps can be connected in parallel.
- This is often seen central heating systems or district heating installations.



Pumps operated in parallel

- Parallel-connected pumps are also used when regulation is required or if an auxiliary pump or standby pump is needed.
- A non-return valve is therefore always mounted on the discharge line to prevent backflow through the pump not operating.

Pumps operated in parallel

- Parallel-connected pumps are also used when regulation is required or if an auxiliary pump or standby pump is needed.
- A non-return valve is therefore always mounted on the discharge line to prevent backflow through the pump not operating.

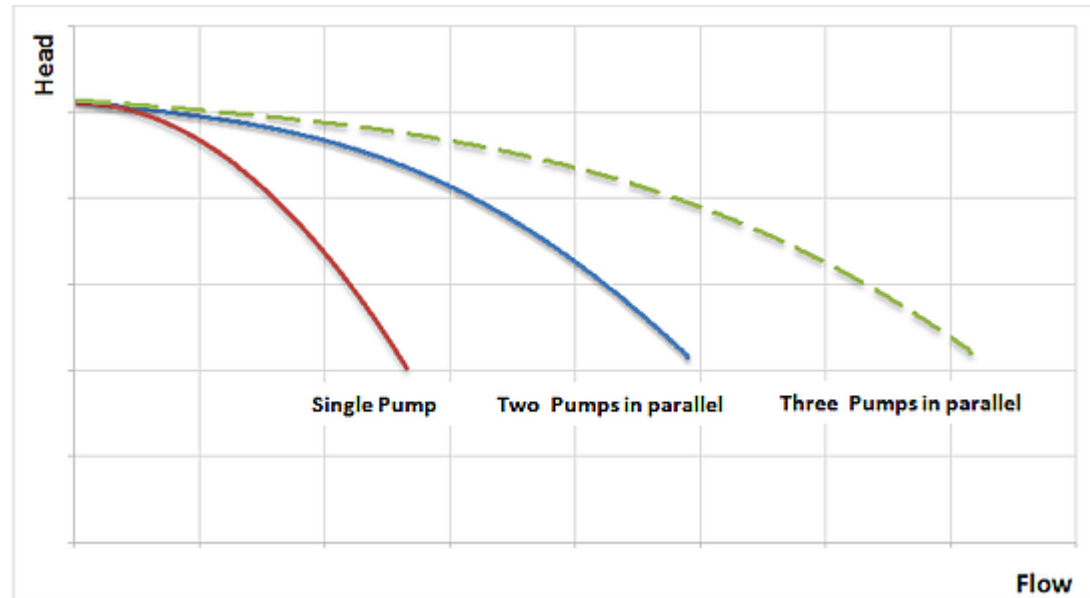
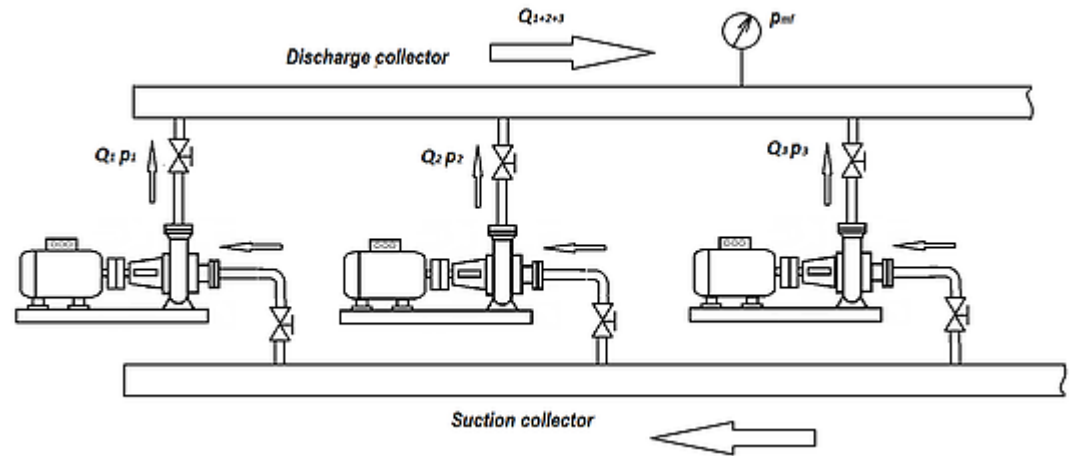



Two similar pumps connected in parallel

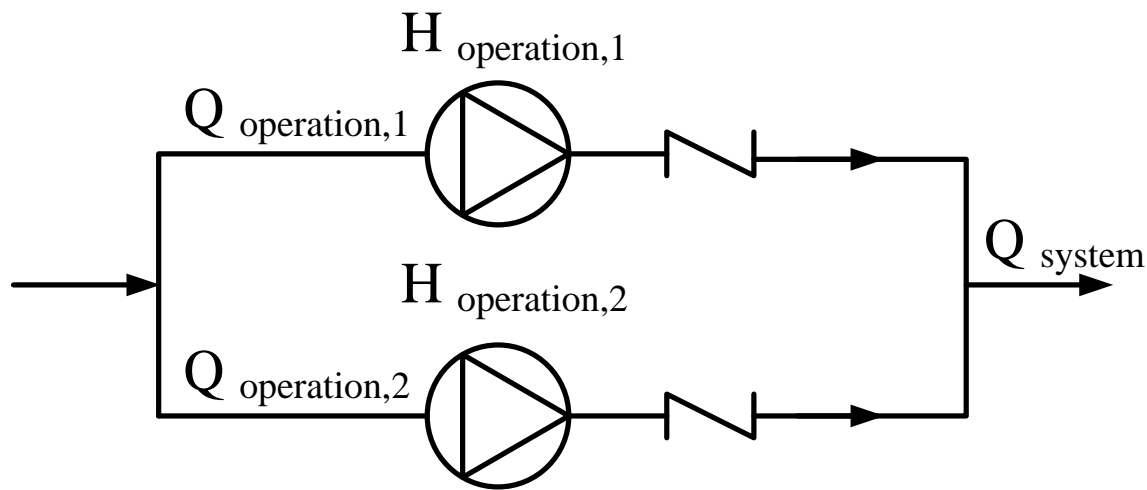

Graph 1

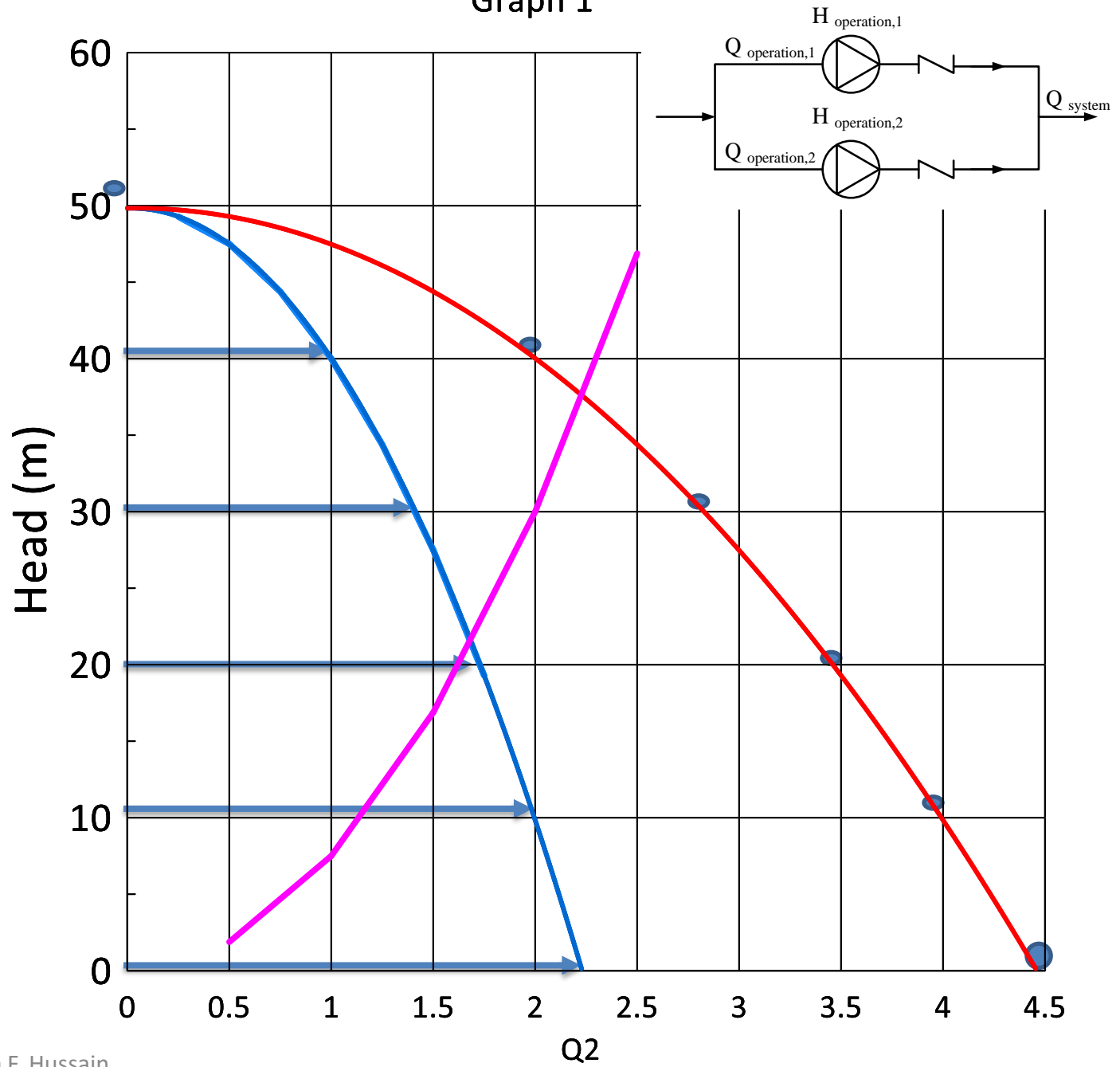

Graph 1

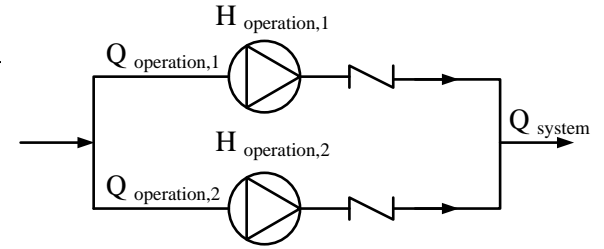
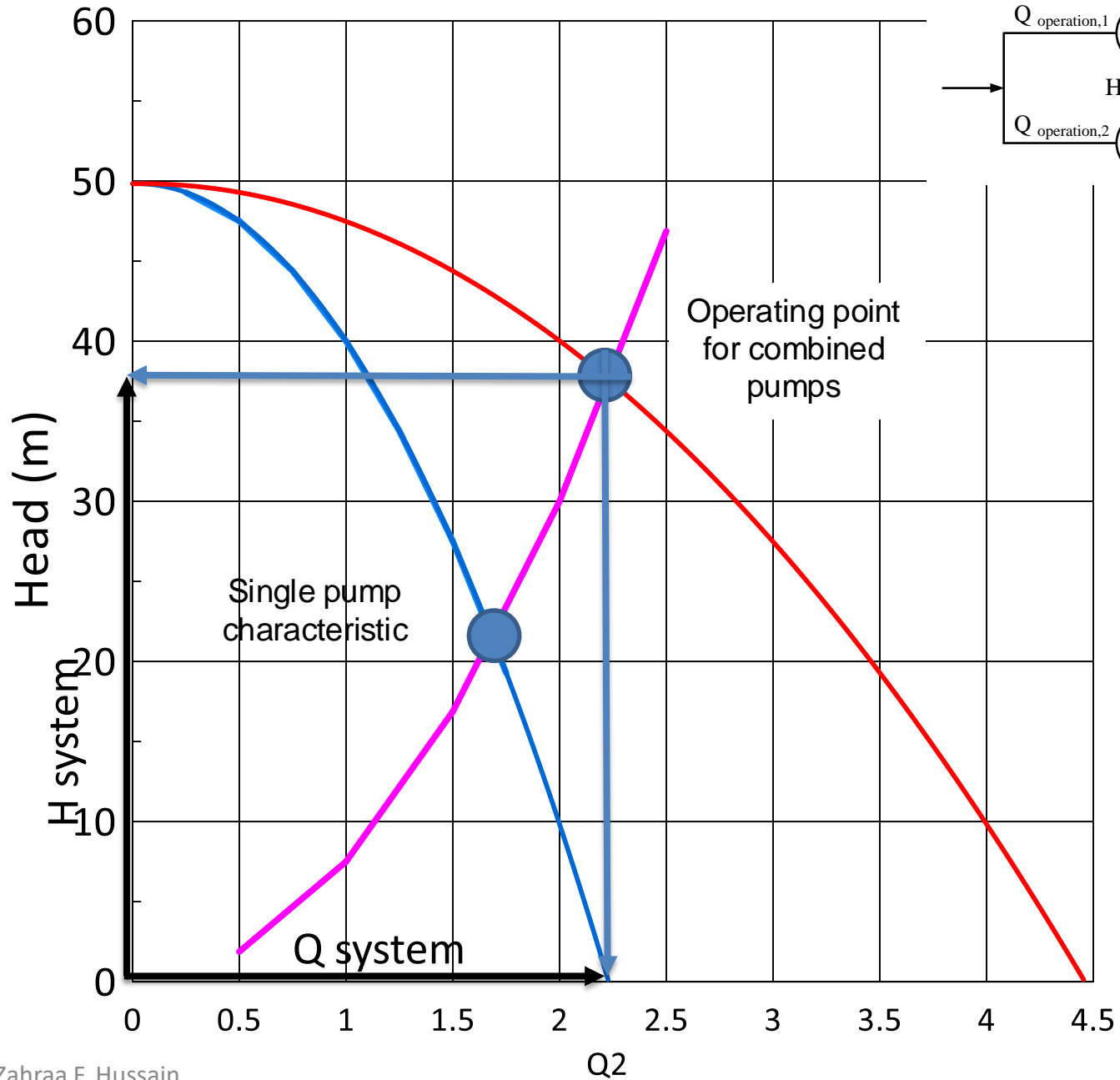

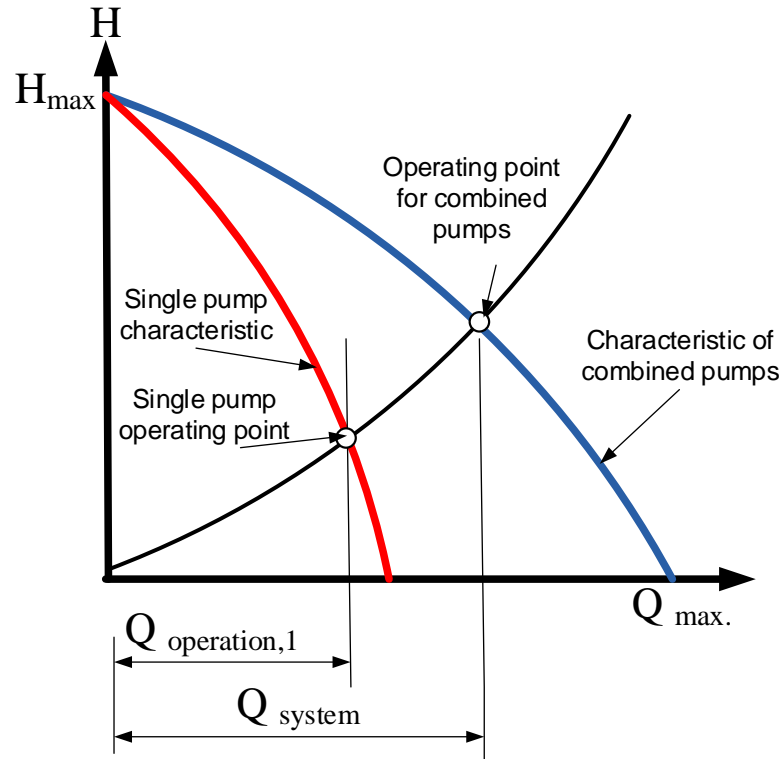
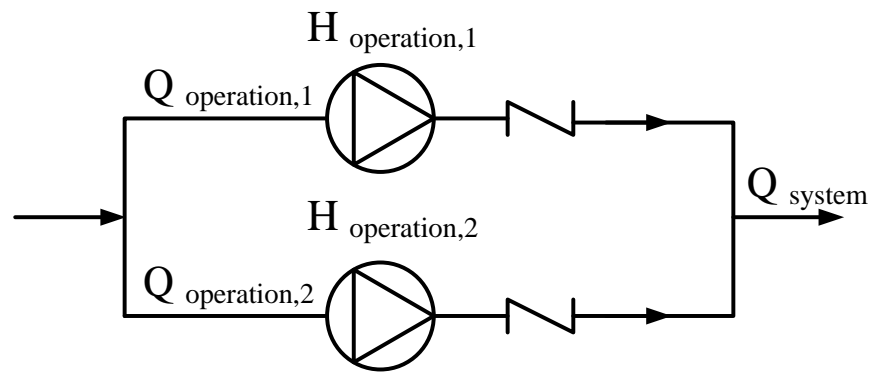

- **Two similar pumps connected in parallel**