

## Experiment No.3

# Center-Tapped Full-Wave Rectifier

### 1. Objectives:

- Construct the center-tapped full-wave rectifier circuit.
- Measure/plot the input and output waveform.
- Find the peak and average values of the output signal

### 2. Components and equipment

- A center-tapped transformer
- An two-channel Oscilloscope.
- An AVO meter
- Breadboard, two semiconductor Diodes, and 1K $\Omega$  Resistor.

### 3. Theory

The circuit of a center-tapped full wave rectifier uses two diodes  $D_1$  and  $D_2$ . During the positive half cycle of secondary voltage, the diode  $D_1$  is forward-biased, and  $D_2$  is reverse-biased. Therefore, the diode  $D_1$  conducts, and current flows through load resistor  $R_L$ , as shown in Fig. 1.

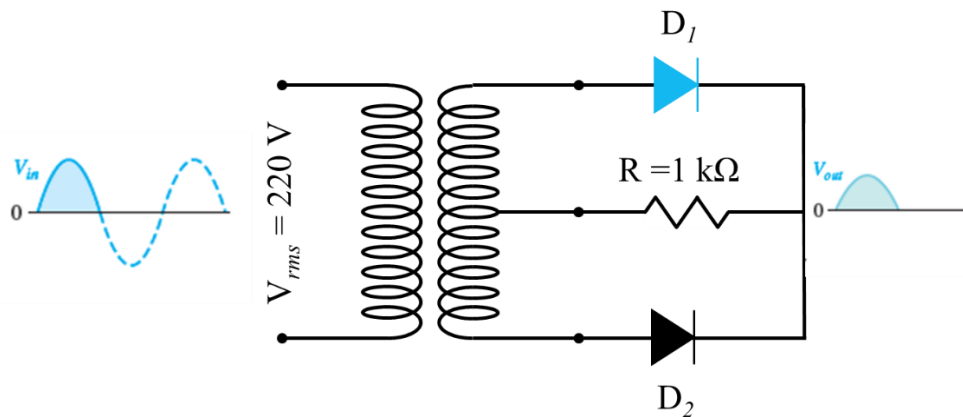

Figure 1: During positive half-cycles,  $D_1$  is forward-biased, and  $D_2$  is reverse-biased.

During the negative half cycle, diode  $D_2$  becomes forward-biased and  $D_1$  reverse-biased. In this case,  $D_2$  conducts, and current flows through the load resistor  $R_L$  in the same direction.

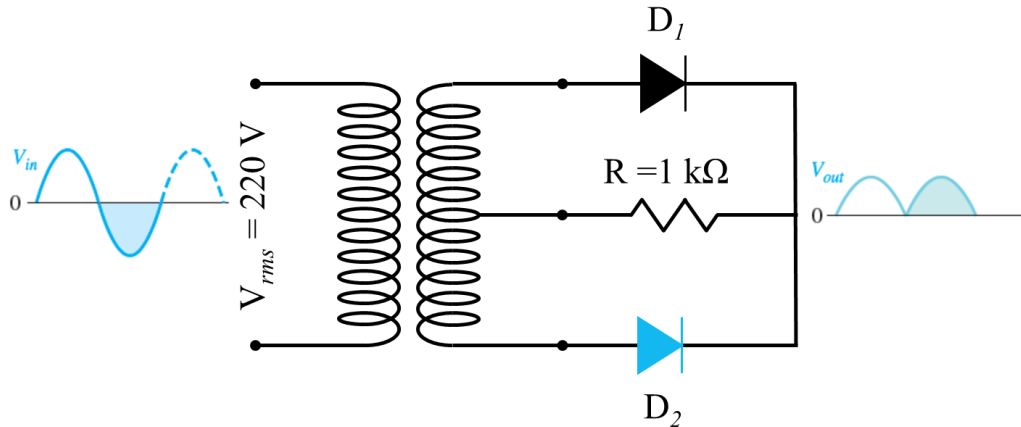

Figure 2: During negative half-cycles,  $D_2$  is forward-biased and  $D_1$  is reverse-biased.

During both half cycles, there is a continuous current flow through the load resistor  $R_L$ , and it will get a unidirectional current, as shown in Fig. 3. The difference between full-wave and half-wave rectification is that a full-wave rectifier allows unidirectional current to the load during the entire  $2\pi$  of the input signal. In contrast, a half-wave rectifier allows this only during one-half cycle  $\pi$ .

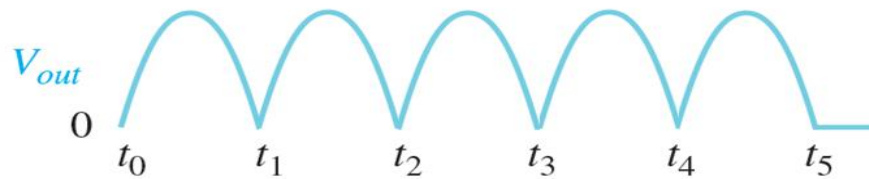

Figure 3: Fig. Output of a full-wave rectifier

### Average Value of the Output Voltage

The average value of a full-wave rectified output voltage is the value you would measure on a DC voltmeter. It can be calculated with the following equation, where  $V_{p(out)}$  is the peak value of the full-wave rectified output voltage:

$$V_{AVG} = \frac{2V_{p(out)}}{\pi}$$



By

Dr. Basim Al-Qargholi

Email: basim.alqargholi@mustaqbal-college.edu.iq

## 4. Experiment procedure

1. Connect the circuit as shown in Fig. 1 using a center-tapped transformer, two diodes, a  $1k\Omega$  resistor ( $R_L$ )
2. Connect the primary winding to the 220 V and a frequency of 50 Hz.
3. Display the input and output signal on the oscilloscope.
4. Measure the  $V_{p,p}$ ,  $V_{max}$ ,  $V_{rms}$ ,  $V_{AVG}$ , and frequency of the input signal.
5. Measure the  $V_{p,p}$ ,  $V_{max}$ ,  $V_{rms}$ ,  $V_{AVG}$ , and frequency of the output signal.
6. Draw the input and output signal
7. Find the turns ratio ( $n$ ) of the transformer
8. Tabulate your measurement results in a table as shown.

Input Signal (FWR) across sec. winding	Output Signal ( $R_L$ )
$V_{rms} =$	$V_{rms} =$
$V_{p(out)} =$	$V_p =$
$V_{p(sec)} =$	$V_{p.p} =$
$V_{AVG} =$ (Exp.)	$V_{AVG} =$ (Exp.)
$V_{AVG} =$ (Theo.)	$V_{AVG} =$ (Theo.)
$f =$	$f =$
Draw the input signal	Draw the output signal
Find the turns ratio ( $n$ ) of the transformer.	

## 5. Discussion

1. Is the transformer step-down or step-up? Why?
2. On a graphic paper, draw the input and output signals, both on one chart (on top of each other). Indicating the voltages ( $V_p$ ,  $V_{rms}$ , and  $V_{AVG}$ ).
3. What would be the output at  $R_L$  if we exchange  $D_1$  by  $R_L$ ?