



Chapter 2

AC to DC Converters (Rectifiers)

21 Introduction

A rectifier is a power electronic device that converts alternating current (AC) which periodically reverses direction, to direct current (DC) which flows in only one direction. The rectifiers can be classified as shown in Figure 2.1.

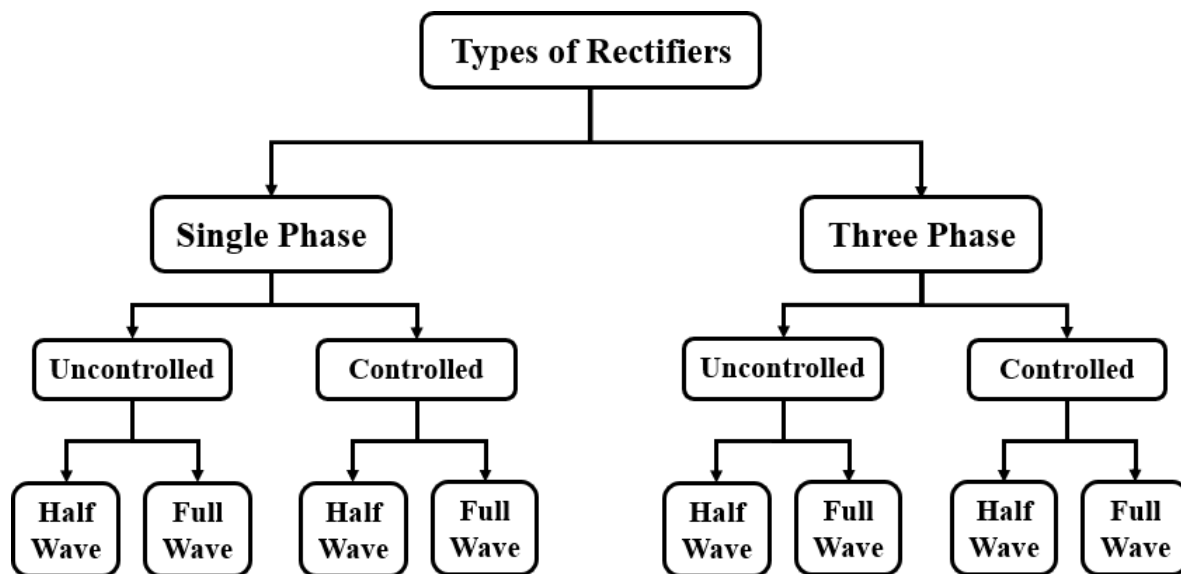

Figure 2.1: Classification of rectifiers.



2.2 Single-Phase Half-Wave Uncontrolled Rectifier

2.2.1 Case of Resistive Load

A basic single-phase half-wave uncontrolled rectifier with a resistive load is shown in Figure 2.2. For the positive half-cycle of the source in this circuit, the diode is ON

(forward biased). For the negative half-cycle of the source, the diode is reverse-biased, making the current zero. The voltage across the diode is the source voltage.

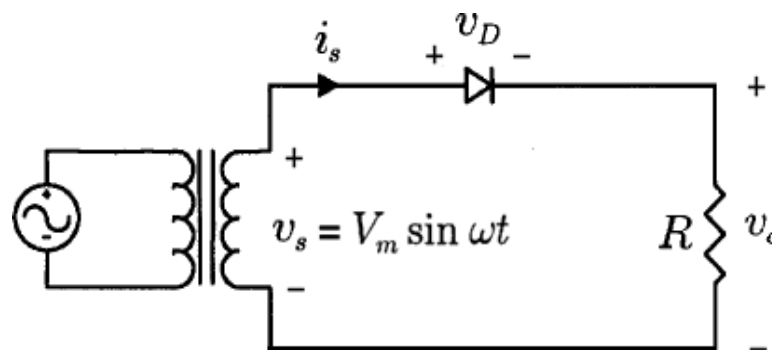

Figure 2.2: A single-phase half-wave uncontrolled rectifier with a resistive load.

Assuming that the transformer provides ideal sinusoidal voltage on its secondary winding, the voltage and current waveforms on resistive load and the voltage waveform on the diode are shown in Figure 2.3.

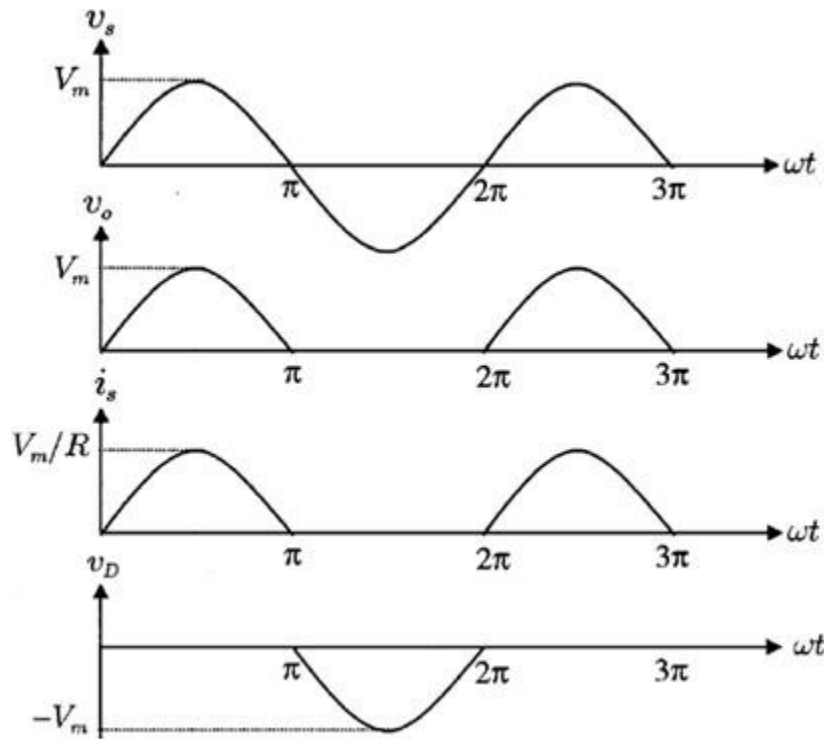

Figure 2.3: The waveforms of the single-phase half-wave uncontrolled rectifier with a resistive load.

The average (mean) value of output

$$\text{voltage, } V_{DC(Load)} = \frac{\text{Area}}{T} = \frac{1}{2\pi} \int_0^\pi v_m \sin \omega t d\omega t$$

$$V_{DC(Load)} = \frac{1}{2\pi} \int_0^\pi v_m \sin \omega t d\omega t$$

To make the solution simpler, we assume $\omega t = \theta$

$$V_{DC(Load)} = \frac{1}{2\pi} \int_0^\pi v_m \sin \theta d\theta = \frac{v_m}{2\pi} [-\cos \theta]_0^\pi = -\frac{v_m}{2\pi} [\cos(\pi) - \cos(0)]$$

$$V_{DC(Load)} = \frac{v_m}{\pi}$$

The average value of output current, $I_{DC(Load)} = \frac{V_{DC(Load)}}{R}$



$$I_{DC(Load)} = \frac{v_m}{\pi R}$$

The RMS value of output voltage, $V_{RMS(Load)} = \sqrt{\frac{1}{2\pi} \int_0^\pi [v_m \sin\theta]^2 d\theta}$

$$V_{RMS(Load)} = \sqrt{\frac{1}{2\pi} \int_0^\pi (v_m)^2 (\sin\theta)^2 d\theta} = \sqrt{\frac{(v_m)^2}{2\pi} \int_0^\pi \frac{1}{2} (1 - \cos 2\theta) d\theta}$$

$$V_{RMS(Load)} = \frac{v_m}{2\sqrt{\pi}} \sqrt{\int_0^\pi 1 d\theta - \int_0^\pi \cos 2\theta d\theta} = \frac{v_m}{2\sqrt{\pi}} \sqrt{[\theta]_0^\pi - [\sin 2\theta]_0^\pi}$$

$$V_{RMS(Load)} = \frac{v_m}{2\sqrt{\pi}} \sqrt{\pi}$$

$$V_{RMS(Load)} = \frac{v_m}{2}$$

The RMS value of output current, $I_{RMS(Load)} = \frac{V_{RMS(Load)}}{R}$

$$I_{RMS(Load)} = \frac{v_m}{2R}$$

The average output DC power, $P_{DC(load)} = V_{DC(load)} I_{DC(load)}$

The power delivered to resistive load, $P_{AC(load)} = V_{AC(load)} I_{AC(load)}$

The input power factor, $PF = \frac{P_{AC(load)}}{V_{s,RMS} I_{s,RMS}}$

The efficiency of a rectifier, $\eta = \frac{P_{DC(load)}}{V_{s,RMS} I_{s,RMS}} * 100\%$



Example 1: For the shown half-wave rectifier, the voltage source is a 120 V with a frequency of 60 Hz. The load resistor is 5 Ω . Determine:

- (a) The average load current.
- (b) The dc and ac power absorbed by the load.
- (c) The input power factor of the circuit.
- (d) The efficiency of the rectifier.

(e) **Solution:**

$$V_{s,RMS} = 120 V, F = 60 \text{ Hz}, R = 5\Omega$$

(a)

$$I_{DC(Load)} = \frac{v_m}{\pi R} \quad v_m = \sqrt{2}V_{s,Rms}$$

$$I_{DC(Load)} = \frac{120\sqrt{2}}{5\pi} = 10.8A$$

$$(b) P_{DC(load)} = V_{DC(load)}I_{DC(load)} \quad , \quad V_{DC(load)} = \frac{v_m}{\pi} = \frac{120\sqrt{2}}{\pi} = 54V$$

$$P_{DC(load)} = (54)(10.8) = 583.2Watt$$

$$P_{AC(load)} = V_{AC(load)}I_{AC(load)} \quad , \quad V_{RMS(load)} = \frac{v_m}{2} = \frac{120\sqrt{2}}{2} = 84.9V$$

$$, \quad I_{RMS(load)} = \frac{V_{RMS}}{R} = \frac{84.9}{5} = 17A$$

$$P_{AC(load)} = (84.9)(17) = 1443.3Watt$$

$$(c) PF = \frac{P_{AC(load)}}{V_{s,RMS}I_{s,RMS}} = \frac{1443.3}{(120)(17)} = 0.707$$

$$(d) \eta = \frac{P_{DC(load)}}{V_{s,RMS}I_{s,RMS}} * 100\% = \frac{583.2}{(120)(17)} * 100\% = 28.5\%$$



2.2.2 Case of R-L Load

Industrial loads typically contain inductance as well as resistance. A basic single-phase half-wave uncontrolled rectifier with resistive and inductance load is shown in Figure 2.4.

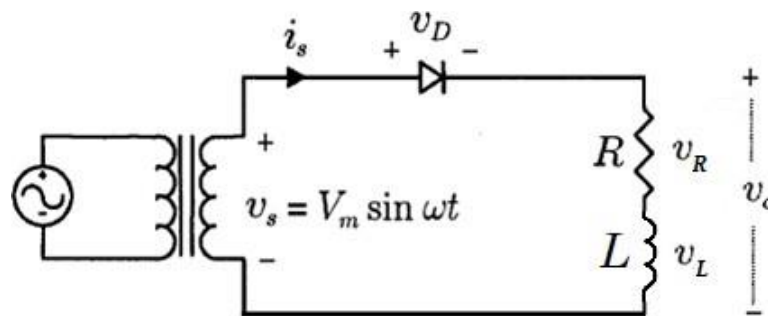

Figure 2.4: A single-phase half-wave uncontrolled rectifier with R-L load.

The Kirchhoff voltage law equation that describes the current in the circuit for the forward-biased ideal diode is:

$$v_m \sin(\omega t) = Ri(t) + L \frac{di(t)}{dt} \quad (1)$$

The solution of equation (1) can be obtained by expressing the current as the sum of the forced response and the natural response:

$$i(t) = i_f(t) + i_n(t)$$

The forced response for this circuit is the current that exists after the natural response has decayed to zero. In this case, the forced response is the steady-state sinusoidal current that would exist in the circuit if the diode was not present. This steady-state current can be found from phasor analysis, resulting in



$$i_f(t) = \frac{v_m}{Z} \sin(\omega t - \varphi)$$

The natural response is the transient that occurs when the load is energized. It is the solution to the homogeneous differential equation for the circuit without the source or diode.

$$i_n(t) = Ae^{-\frac{t}{\tau}}$$

The final current equation can be written as:

$$i(\omega t) = \begin{cases} \frac{v_m}{Z} \left[\sin(\omega t - \varphi) + \sin(\varphi) e^{-\frac{\omega t}{\tau}} \right], & 0 \leq \omega t \leq \beta \\ 0, & \beta \leq \omega t \leq 2\pi \end{cases}$$

$$\text{Where } Z = \sqrt{R^2 + (\omega L)^2}, \quad \varphi = \tan^{-1} \left(\frac{\omega L}{R} \right), \quad \tau = \frac{L}{R}$$

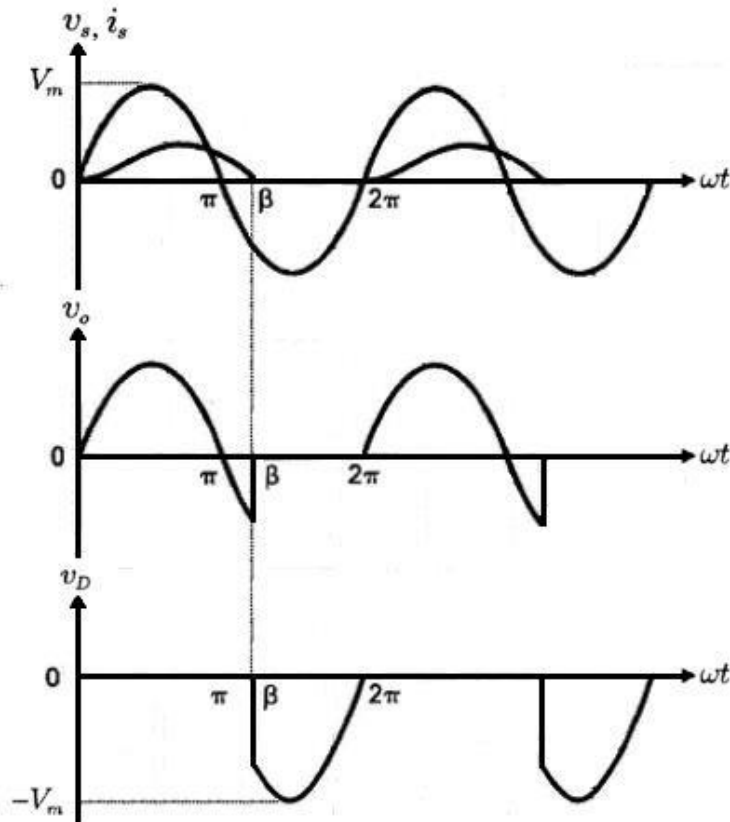

Figure 2.5: The waveforms of the single-phase half-wave uncontrolled rectifier with R-L load.

β : The conduction angle of the diode

$$V_{DC(Load)} = \frac{1}{2\pi} \int_0^{\beta} v_m \sin \omega t d\omega t$$

$$V_{DC(Load)} = \frac{v_m}{2\pi} [1 - \cos(\beta)]$$

The average value of output current, $I_{DC(Load)} = \frac{V_{DC(Load)}}{R}$

$$I_{DC(Load)} = \frac{v_m}{2\pi R} [1 - \cos(\beta)]$$



The RMS value of output voltage, $V_{RMS(Load)} = \sqrt{\frac{1}{2\pi} \int_0^\beta [v_m \sin(\omega t)]^2 d\omega t}$

$$V_{RMS(Load)} = \sqrt{\frac{v_m^2}{4\pi} [\beta - \frac{1}{2} \sin(2\beta)]}$$

The RMS value of output current, $I_{RMS(Load)} = \sqrt{\frac{1}{2\pi} \int_0^\beta [i(\omega t)]^2 d\omega t}$

Example 2: For the half-wave uncontrolled rectifier with R-L load, the voltage source is a 70.7 V with a frequency of 60 Hz. The load comprise resistance of 100 Ω and inductance of 0.1 H. Assume the conduction angle equal to 3.5 rad and then determine:

- (a) An expression for the current in this circuit.
- (b) The average current and voltage.
- (c) The rms voltage.
- (d) The efficiency of the rectifier if the RMS current is equal to 0.47 A.

Solution:

$$V_{s,RMS} = 70.7 V, \quad V_m = 100 V,$$

$$F = 60 Hz, \quad \omega = 377 rad/sec,$$

$$R = 100 \Omega, \quad L = 0.1H, \beta = 3.5 rad = 201^\circ$$



(a)

$$i(\omega t) = \begin{cases} \frac{v_m}{Z} \left[\sin(\omega t - \varphi) + \sin(\varphi) e^{-\frac{\omega t}{\tau}} \right], & 0 \leq \omega t \leq \beta \\ 0, & \beta \leq \omega t \leq 2\pi \end{cases}$$

$$Z = \sqrt{R^2 + (\omega L)^2} = \sqrt{(100)^2 + (37.7)^2} = 106.9\Omega$$

$$\varphi = \tan^{-1} \left(\frac{\omega L}{R} \right) = \tan^{-1} \left(\frac{37.7}{100} \right) = 20.7$$

$$\tau = \frac{L}{R} = \frac{0.1}{100} = 0.001$$

$$i(\omega t) = \begin{cases} 0.936 \left[\sin(\omega t - 20.7) + \sin(20.7) e^{-\frac{\omega t}{0.377}} \right], & 0 \leq \omega t \leq \beta \\ 0, & \beta \leq \omega t \leq 2\pi \end{cases}$$

(b) $I_{DC(Load)} = \frac{v_m}{2\pi R} [1 - \cos(\beta)]$

$$I_{DC(Load)} = \frac{100}{2\pi(100)} [1 - \cos(201)] = 0.308A$$

$$V_{DC(Load)} = \frac{v_m}{2\pi} [1 - \cos(\beta)]$$

$$V_{DC(Load)} = \frac{100}{2\pi} [1 - \cos(201)] = 30.8V$$

(c)

$$V_{RMS(Load)} = \sqrt{\frac{v_m^2}{4\pi} \left[\beta - \frac{1}{2} \sin(2\beta) \right]}$$

$$V_{RMS(Load)} = \sqrt{\frac{100^2}{4\pi} \left[3.5 - \frac{1}{2} \sin(2(201)) \right]} = 50.2V$$

$$(e) \eta = \frac{P_{DC(load)}}{V_{s,RMS} I_{s,RMS}} * 100\% = \frac{V_{DC(load)} I_{DC(load)}}{V_{s,RMS} I_{s,RMS}} * 100\%$$

2.2.3 Case of R-L Load with Freewheeling Diode

A freewheeling diode can be connected across an R-L load as shown in Figure 2.6 (a). The freewheeling diode is used to prevent the output voltage from becoming negative. In addition, the energy stored in inductance is transferred to resistance load through the freewheeling diode, which means the system efficiency is improved.

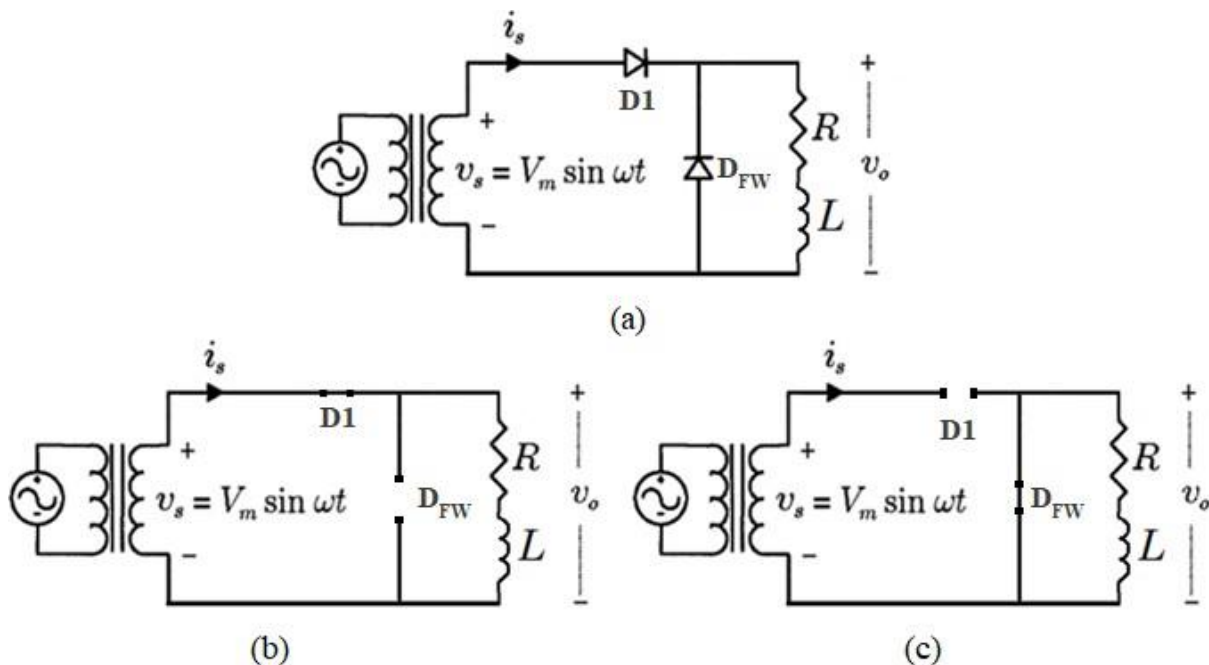

Figure 2.6: A single-phase half-wave uncontrolled rectifier with R-L load using freewheeling diode.

For a positive half-cycle of the source:

- D1 is on.
- D_{FW} is off.
- The equivalent circuit is the same as that of Figure 2.6 (b).



➤ The voltage across the R-L load is the same as the source.
For a negative half-cycle of the source:

- D1 is off.
- D_{FW} is on.
- The equivalent circuit is the same as that of Figure 2.6 (c).
- The voltage across the R-L load is zero.

23 Single-Phase Full-Wave Bridge Uncontrolled Rectifier

A basic single-phase full-wave bridge uncontrolled rectifier with a resistive load is shown in Figure 2.7. This type of single-phase rectifier uses four individual rectifying diodes connected in a closed loop “bridge” configuration to produce the desired output. The four diodes labelled D_1 to D_4 are arranged in “series pairs” with only two diodes conducting current during each half cycle. The voltage and current waveforms on resistive load and the voltage waveform on the diodes are shown in Figure 2.8.

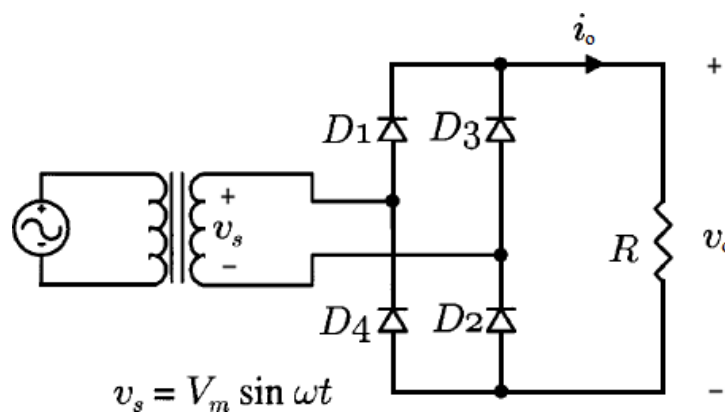

Figure 2.7: A single-phase full-wave bridge uncontrolled rectifier with a resistive load.



Al-Mustaqbal University College
Department of Medical Instrumentation Techniques Engineering
Class: Third
Subject: Power Electronic
Lecturer: Dr. Mayasah Razzaq Al-ghazaly
Lecture: 2

During the positive half cycle of the supply, diodes D_1 and D_2 conduct in series while diodes D_3 and D_4 are reverse biased and the current flows through the load.

- During the negative half cycle of the supply, diodes D_3 and D_4 conduct in series, but diodes D_1 and D_2 switch “OFF” as they are now reverse biased. The current flowing through the load is the same direction as before.

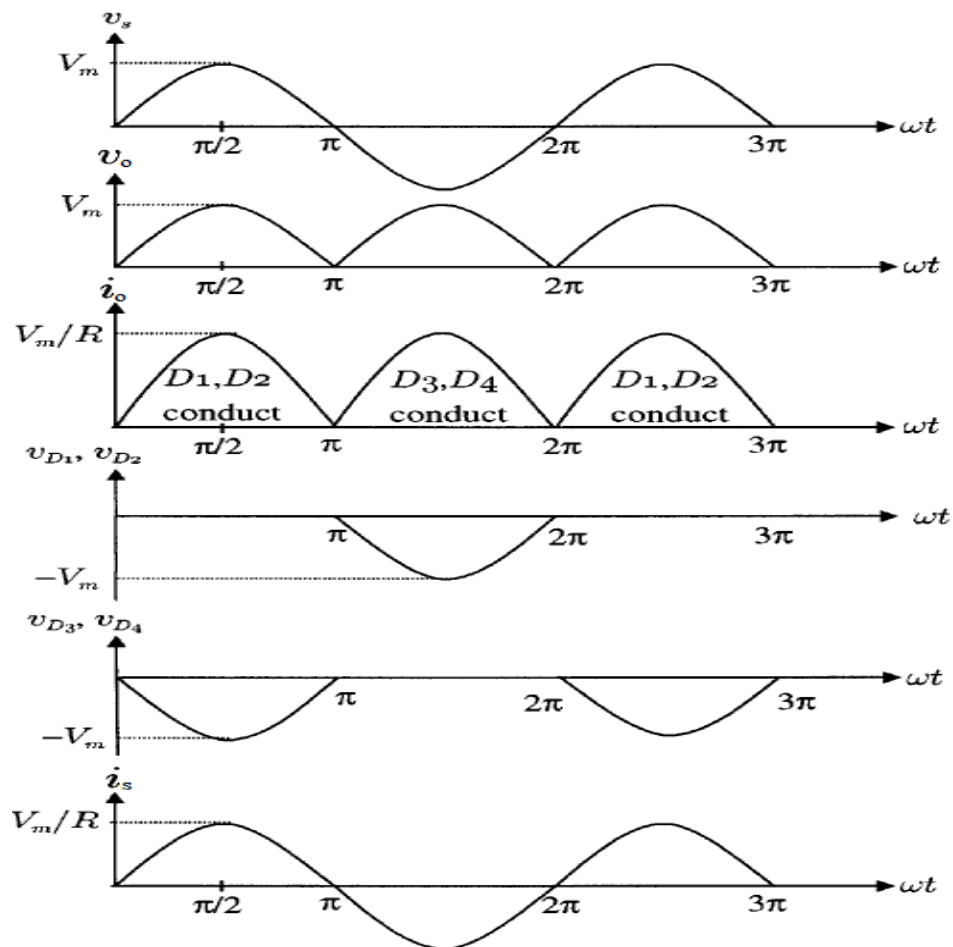
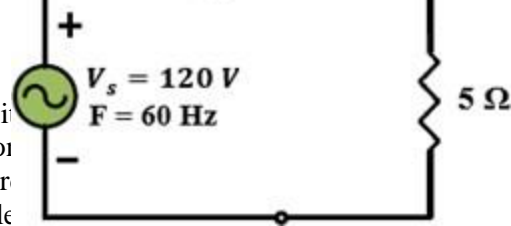

Figure 2.8: The waveforms of the single-phase full-wave bridge uncontrolled rectifier with a resistive load.



$$V_{DC(Load)} = \frac{1}{\pi} \int_0^{\pi} v_m \sin \omega t d\omega t$$

$$V_{DC(Load)} = \frac{2v_m}{\pi}$$

$$I_{DC(Load)} = \frac{V_{DC(Load)}}{R}$$

$$I_{DC(Load)} = \frac{2v_m}{\pi R}$$

$$V_{RMS(Load)} = \sqrt{\frac{1}{\pi} \int_0^{\pi} [v_m \sin \omega t]^2 d\omega t}$$

$$V_{RMS(Load)} = \frac{v_m}{\sqrt{2}}$$

$$I_{RMS(Load)} = \frac{V_{RMS(Load)}}{R}$$

$$I_{RMS(Load)} = \frac{v_m}{\sqrt{2}R}$$

Peak repetitive diode current, $I_m = \frac{v_m}{R}$

$$I_{DC(diode)} = \frac{1}{2\pi} \int_0^{\pi} I_m \sin \omega t d\omega t = \frac{I_m}{\pi}$$

$$I_{RMS(diode)} = \frac{1}{2\pi} \int_0^{\pi} [I_m \sin \omega t]^2 d\omega t = \frac{I_m}{2}$$

Example 3: The single-phase full-wave bridge uncontrolled rectifier is supported by a 120 V source. If the load resistance is 10.8 Ω , find:



- a) The DC voltage across the load
- b) The DC load current.
- c) The average current in each diode.
- d) The DC output power.
- e) The rectifier efficiency.
- f) The ripple factor.

Solution:

$$V_{s,RMS} = 120 V, \quad R = 10.8 \Omega$$

(a)

$$V_{DC(Load)} = \frac{2v_m}{\pi}, \quad v_m = \sqrt{2}V_{s,RMS}$$

$$V_{DC(Load)} = \frac{2v_m}{\pi} = \frac{2(120\sqrt{2})}{\pi} = 108V$$

(b)

$$I_{DC(Load)} = \frac{V_{DC(Load)}}{R}$$

$$I_{DC(Load)} = \frac{108}{10.8} = 10 A$$



(c)

$$I_{DC(diode)} = \frac{I_m}{\pi} \quad , \quad I_m = \frac{v_m}{R}$$

$$I_{DC(Load)} = \frac{15.7}{\pi} = 5A$$

(d)

$$P_{DC(load)} = V_{DC(load)} I_{DC(load)}$$
$$P_{DC(load)} = (108)(10) = 1080Watt$$

(a)

$$\eta = \frac{P_{DC(load)}}{V_{s,RMS} I_{s,RMS}} * 100\% \quad , \quad I_{s,RMS} = \frac{v_m}{\sqrt{2}R} = \frac{120\sqrt{2}}{10.8\sqrt{2}} = 11A$$

$$\eta = \frac{1080}{(120)(11)} * 100\% = 81\%$$

(f)

$$RF = \sqrt{\left(\frac{V_{RMS(Load)}}{V_{DC(Load)}}\right)^2 - 1} = \sqrt{\left(\frac{120}{108}\right)^2 - 1} = 0.484$$

2.3.1 Single-phase full-wave bridge uncontrolled rectifier loaded with highly inductive load

Adding an inductance in series with the load resistance changes the current waveform. A basic single-phase full-wave bridge uncontrolled rectifier with resistive and inductance load is shown in Figure 2.9.

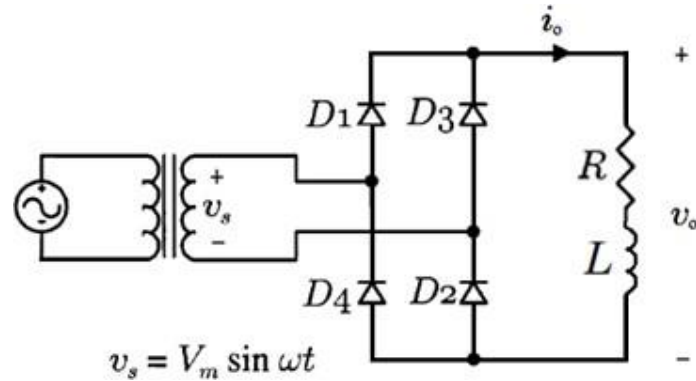

Figure 2.9: A single-phase full-wave bridge uncontrolled rectifier with R-L load.

If **L** is approximately equal to **R**, the load current no longer consists of half sine waves, but the average current is still the same as given by equation:

$$I_{DC(Load)} = \frac{2v_m}{\pi R}$$

For the bridge circuit, current is transferred from one pair of diodes to the other pair when the source changes polarity. The voltage across the R-L load is a full-wave rectified sinusoid, as it was for the resistive load.

$$V_{DC(Load)} = \frac{2v_m}{\pi} \quad , \quad V_{RMS(Load)} = \frac{v_m}{\sqrt{2}}$$

In some applications, the load inductance may be relatively large or made large by adding external inductance. If **L** is much higher than **R** ($L \gg R$), the load time constant L/R is very high and can be considered infinity. Consequently, the load current is assumed constant and the circuit behavior is as shown by the waveforms in Figure 2.10.



Al-Mustaqbal University College
Department of Medical Instrumentation Techniques Engineering
Class: Third
Subject: Power Electronic
Lecturer: Dr. Mayasah Razzaq Al-ghazaly
Lecture: 2

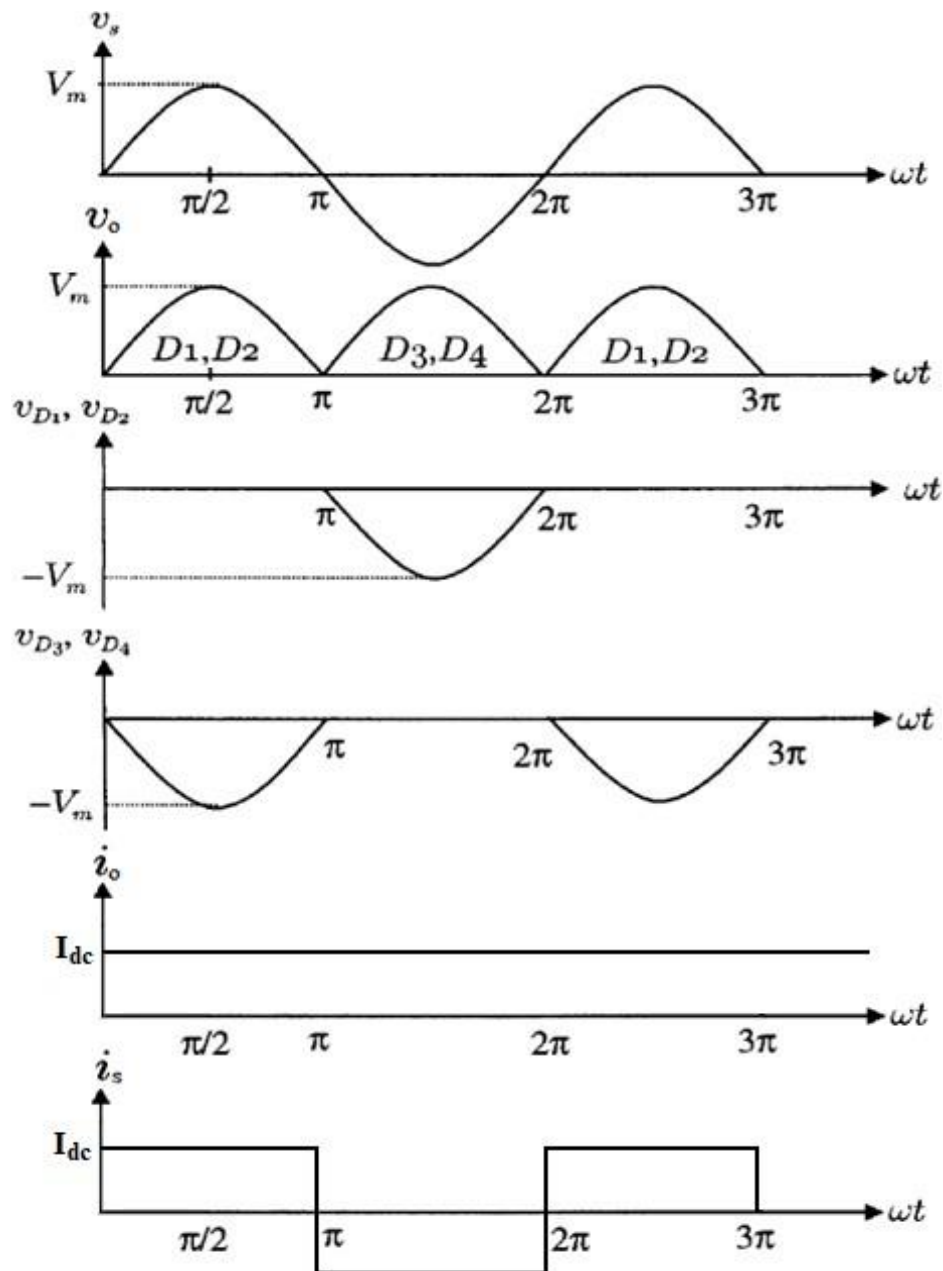

Figure 2.10: The waveforms of the single-phase full-wave bridge uncontrolled rectifier loaded with highly inductive load.



Same as the case of resistive load, the average value of the load voltage and current can be calculated as follows:

$$V_{DC(Load)} = \frac{2v_m}{\pi}$$

$$I_{DC(Load)} = \frac{V_{DC(Load)}}{R}$$

$$I_{DC(Load)} = \frac{2v_m}{\pi R}$$

However the rms value of the load voltage can be calculated as follows:

$$V_{RMS(Load)} = \frac{v_m}{\sqrt{2}}$$

Since the load current is essentially constant, its RMS and average values are same:

$$I_{RMS(Load)} = I_{DC(Load)}$$

Example 4: The single-phase full-wave bridge uncontrolled rectifier with R-L load is connected to a 120 V source. If the load resistance is 10 Ω and $L \gg R$, find:

- The average load voltage and current.
- The RMS value of load current.
- The average current in each diode.
- The ripple factor.

Solution:

$$V_{s,RMS} = 120 \text{ V}, \quad R = 10 \Omega, \quad L \gg R$$

(a)

$$V_{DC(Load)} = \frac{2v_m}{\pi}, \quad v_m = \sqrt{2}V_{s,RMS}$$



$$V_{DC(Load)} = \frac{2(120\sqrt{2})}{\pi} = 108V$$

$$I_{DC(Load)} = \frac{V_{DC(Load)}}{R} = \frac{108}{10} = 10.8A$$

(b)

$$I_{RMS(Load)} = I_{DC(Load)} = 10.8A$$

(c)

$$I_{DC(diode)} = \frac{I_{DC(Load)}}{2} = \frac{10.8}{2} = 5.4A$$

(d)

$$RF = \sqrt{\left(\frac{V_{RMS(Load)}}{V_{DC(Load)}}\right)^2 - 1} = \sqrt{\left(\frac{120}{108}\right)^2 - 1} = 0.484$$

Assignment 2

1. An ideal single-phase source of 240 V, 60 Hz, supplies power to a load resistor of $R = 100 \Omega$ via a single ideal diode. Determine:
 - (a) The average and RMS values of load current.
 - (b) The power dissipation.
 - (c) The circuit power factor.
 - (d) What must be the rating of the diode?
2. For the circuit shown in Figure below. Neglecting the diode voltage drop, calculate the average load voltage and current, then sketch the output current waveform if (a) the load is a pure resistor of 10 ohms, (b) the load is an inductance of 0.1 H in series with a 10 ohms resistor. Assume the extinction angle $\beta = 265^\circ$.



Al-Mustaqbal University College
Department of Medical Instrumentation Techniques Engineering
Class: Third
Subject: Power Electronic
Lecturer: Dr. Mayasah Razzaq Al-ghazaly
Lecture: 2

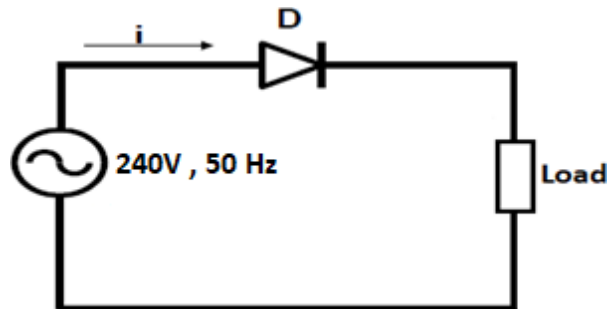

1. A single-phase full-wave uncontrolled bridge rectifier is supplying a highly inductive load (L/R ratio is very large). If the supply voltage is 220V, 50Hz, and the load resistance $R=22 \Omega$, Calculate:
 - (a) The average output voltage and current.
 - (b) The rms value of the output voltage and current.
 - (c) The rms value of the diode current and the PRV of each diode.
2. In a single-phase full-wave bridge uncontrolled rectifier, the diodes have a reverse recovery time of $40 \mu s$. If the ac input voltage is 230 V, determine the effect of reverse recovery time on the average output voltage for a supply frequency of (a) 50 Hz and (b) 2.5 kHz.
3. A single-phase full-wave bridge diode rectifier is supplied from 230 V, 50 Hz source. If the load is highly inductive with a resistance of $R = 10$. Sketch v_{in} , v_o , v_{D2} , v_{D3} , i_o and i_s waveforms, and then determine:
 - (a) The average values of output voltage and output current.
 - (b) The average and RMS values of diode current.
 - (c) The ripple factor.



2.4 Three-Phase Half-Wave Uncontrolled Rectifier

A basic three-phase half-wave uncontrolled rectifier circuit with resistive load is shown in Figure 2.11. The rectifier is fed from an ideal 3-phase supply through delta-star transformer.

The diode in a particular phase conducts during the period when the voltage on that phase is higher than that on the other two phases. For example: from $\pi/6$ to $5\pi/6$, D_1 has a more positive voltage at its anode, in this period D_2 and D_3 are off. The neutral wire provides a return path to the load current.

Unlike the single-phase rectifier circuit, the conduction angle of each diode is $2\pi/3$, instead of π . The voltage and current waveforms on resistive load and the voltage and current waveforms on D_1 are shown in Figure 2.12.