



Analog electronics

Fourth lecture

Types of Amplifiers and its Characteristics

Dr. Mohammed Hashim

MS. Noor Hayder

Third stage

Department of medical physics

Al-Mustaqbal University-College

2022- 2023

Outline

1. What is an Amplifier?
2. What is a Common Emitter Amplifier?
3. Properties of common emitter amplifier
4. Drawing the Load Line
5. Biasing circuits
6. biasing aims
7. References

4.1 What is an Amplifier?

The Amplifier is an electronic circuit that is used to increase the strength of a weak input signal in terms of voltage, current, or power. The process of increasing the strength of a weak signal is known as Amplification. One most important constraint during the amplification is that only the magnitude of the signal should increase and there should be no changes in the original signal shape. The transistor (BJT, FET) is a major component in an amplifier system.

4.2 What is a Common Emitter Amplifier?

The common emitter amplifier **is a three basic single-stage bipolar junction transistor and is used as a voltage amplifier.** The input of this amplifier is taken from the base terminal, the output is collected from the collector terminal and the emitter terminal is common for both the terminals. The basic symbol of the common emitter amplifier is shown below.

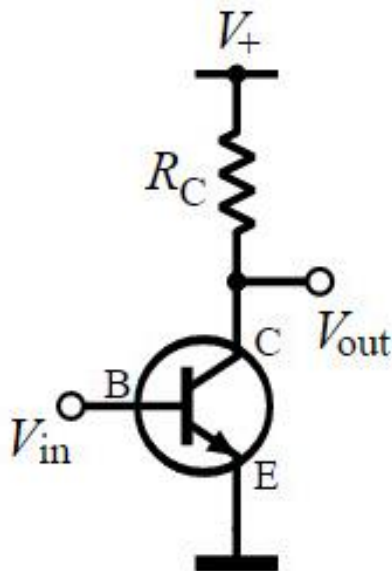

Figure 1: Common Emitter Amplifier.

4.3 Properties of common emitter amplifier

The Properties of a common emitter amplifier include the following:

1. The common emitter amplifier has a low input resistance
2. The common emitter amplifier is an inverting amplifier
3. The output resistance of this amplifier is high
4. This amplifier has the highest power gain when combined with medium voltage and current gain
5. The current gain of the common emitter amplifier is high

4.4 Drawing the Load Line

The load line is a graph that has all possible volumes of output current (I_C) and output voltage (V_{CE}) for a given amplifier.

The circuit diagram of the DC (Direct Current) load line using a transistor is shown below. As shown in the figure, the DC battery V_{BB} is applied at the base and the collector terminals of the transistor. The voltage between collector and emitter is called V_{CE} and voltage between bias and emitter is called V_{BE} . To get the dc load line, we need to **apply Kirchhoff's** Voltage Law to the output:

$$V_{CC} - I_C * R_C - V_{CE} = 0$$

Case 1: If we put $I_C = 0$, then will get $V_{CE} = V_{CC}$

Case 2: If we put $V_{CE} = 0$, then I_C becomes V_{CC} / R_C

By using the above two cases we can easily draw the dc load line for output characteristics. The dc load line is a graph of all values of I_C and V_{CE} .

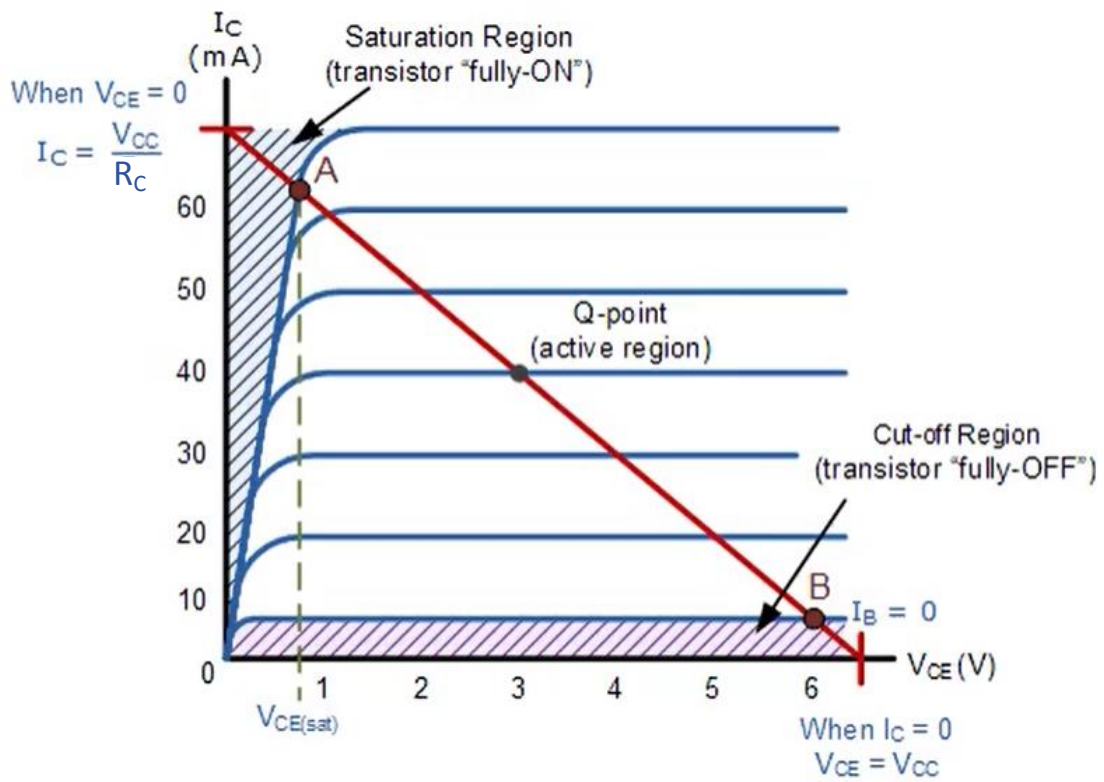
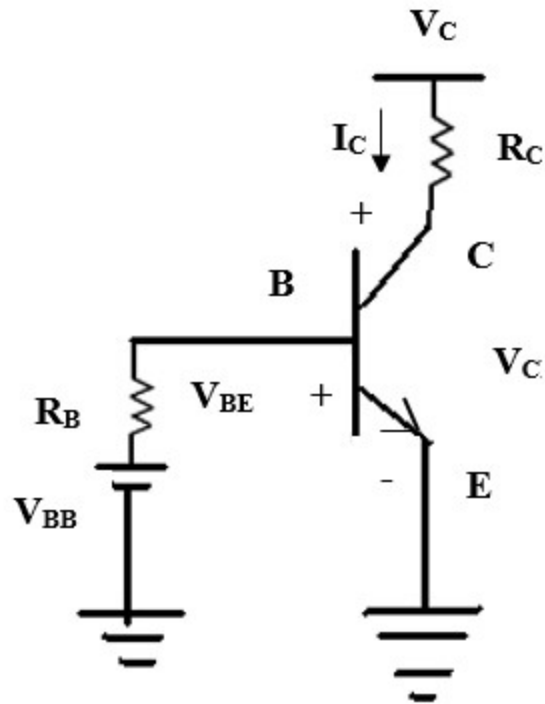

Figure 1: transistor-dc-load-line.

4.5 Biasing circuits

Biasing is the process of providing DC voltage which helps in the functioning of the circuit. A transistor is biased in order to make the emitter base junction forward biased and collector base junction reverse biased, so that it maintains in active region, to work as an amplifier.

Forward Bias: The negative source terminal is connected to the n-type material, and the positive terminal is connected to the p-type material. This connection produces what is called forward bias. the battery pushes holes and free electrons toward the junction. When the dc voltage source is greater than the barrier potential, the battery again pushes holes and free electrons toward the junction. This time, the free electrons have enough energy to pass through the depletion layer and recombine with the holes.

Reverse Bias: the negative battery terminal is connected to the p-type , and the positive battery terminal to the n-type. This connection produces what is called reverse bias. The negative battery terminal attracts the holes, and the positive battery

terminal attracts the free electrons. Because of this, holes and free electrons flow away from the junction. Therefore, the depletion layer gets wider.

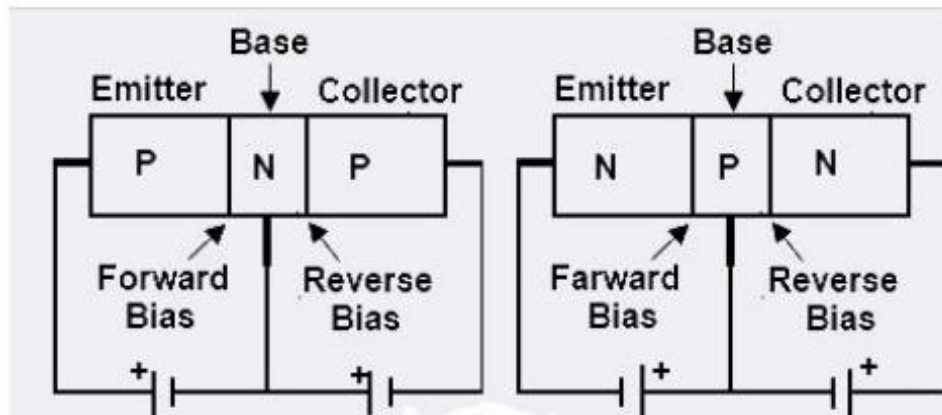

Figure 2: transistor biasing, PNP and NPN transistor.

Figure 3 shows the usual way to bias a transistor. The minus signs represent free electrons. The heavily doped emitter has the following job: to emit or inject its free electrons into the base. The lightly doped base also has a well-defined purpose: to pass emitter-injected electrons on to the collector. The collector is so named because it collects or gathers most of the electrons from the base.

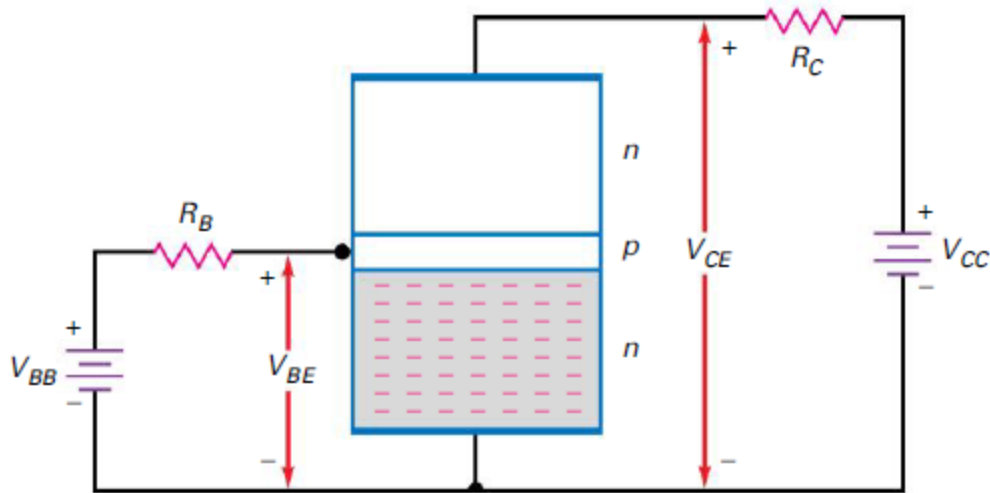

Figure 3: NPN Biased transistor.

Relation of Currents

When applied to a transistor, Kirchhoff's current law gives us this important relationship:

$$I_E = I_C + I_B \quad I_C \approx I_E$$

$$\alpha_{dc} = \frac{I_C}{I_E} \quad \beta_{dc} = \frac{I_C}{I_B}$$

The dc **beta** is also known as the **current gain** because a small base current controls a much larger collector current.

Example 6-1

A transistor has a collector current of 10 mA and a base current of 40 μA . What is the current gain of the transistor?

SOLUTION Divide the collector current by the base current to get:

$$\beta_{dc} = \frac{10 \text{ mA}}{40 \mu\text{A}} = 250$$

PRACTICE PROBLEM 6-1 What is the current gain of the transistor in Example 6-1 if its base current is 50 μA ?

Example 6-2

A transistor has a current gain of 175. If the base current is 0.1 mA, what is the collector current?

SOLUTION Multiply the current gain by the base current to get:

$$I_C = 175(0.1 \text{ mA}) = 17.5 \text{ mA}$$

PRACTICE PROBLEM 6-2 Find I_C in Example 6-2 if $\beta_{dc} = 100$.

4.6 Biasing Aims

The goal of Transistor Biasing is to establish a known operating point, or Q-point for the bipolar transistor to work efficiently and produce an undistorted output signal.

3.7 References

Electronics principles (fourth edition) by Malvino.