



**Lecturer: Dr. Ameer Al-khaykan**

## **Lecture: Bipolar Junction Transistors (BJTs)**

### **Basic Construction:**

The transistor is a three-layer semiconductor device consisting of either two  $n$ - and one  $p$ -type layers of material or two  $p$ - and one  $n$ -type layers of material. The former is called an *npn transistor*, while the latter is called a *pnp transistor*. Both (with symbols) are shown in Fig. 8-1. The middle region of each transistor type is called the *base (B)* of the transistor. Of the remaining two regions, one is called *emitter (E)* and the other is called the *collector (C)* of the transistor. For each transistor type, a junction is created at each of the two boundaries where the material changes from one type to the other. Therefore, there are two junctions: *emitter-base (E-B) junction* and *collector-base (C-B) junction*. The outer layers of the transistor are heavily doped semiconductor materials having widths much greater than those of the sandwiched  $p$ - or  $n$ -type material. The doping of the sandwiched layer is also considerably less than that of the outer layers (typically 10:1 or less). This lower doping level decreases the conductivity (increases the resistance) of this material by limiting the number of "free" carriers.

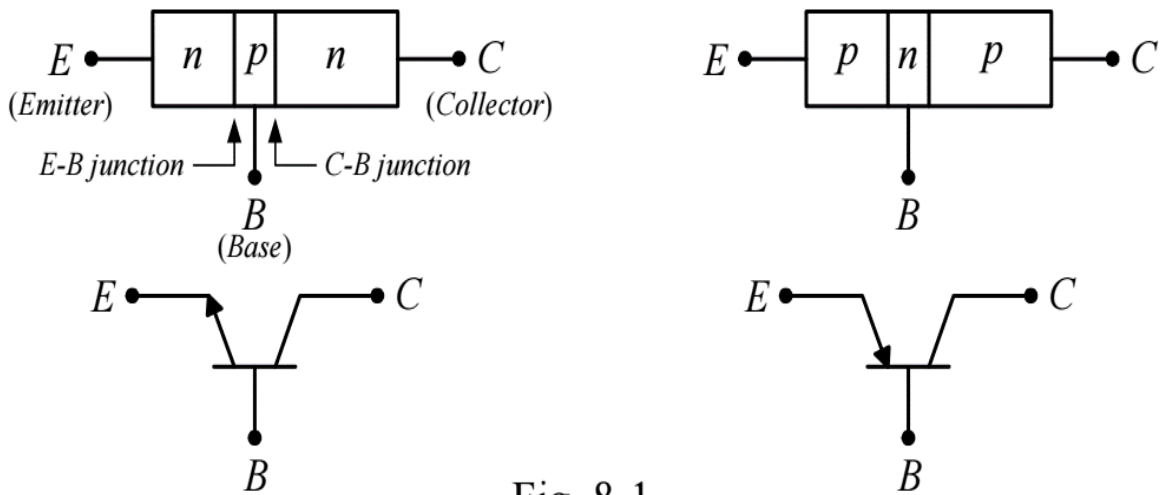

Fig. 8-1

The dc biasing is necessary to establish the proper region of operation for ac amplification or switching purposes. Table 8-1 shows the transistor operation regions and the purpose with respect to the biasing of the E-B and C-B junctions.

Table 8-1

Operation region		Purpose	Junctions biasing	
			E-B junction bias	C-B junction bias
1	Active region	Amplification	Forward-biased	Reverse-biased
2	Cutoff region	Switching	Reverse-biased	Reverse-biased
3	Saturation region		Forward-biased	Forward-biased

The abbreviation **BJT**, from **bipolar junction transistor**, is often applied to this three-terminal device. The term **bipolar** reflects the fact that holes and electrons participate in the injection process into the oppositely polarized material. If only one carrier is employed (electron or hole), it is considered a **unipolar** device. Such a device is the **field-effect transistor (FET)**.

### Active Region Operation:

The basic operation of the transistor will now be described using the pnp transistor of Fig. 8-2. The operation of the npn transistor is exactly the same if the roles played by the electron and hole are interchanged. When the E-B junction is forward-biased, a large number of majority carriers will diffuse across the forward-biased p-n junction into the n-type material (base). Since the base is very thin and has a low conductivity (lightly doping), a very small number of these carriers will take this path of high resistance to the base terminal. The larger number of these majority carriers will diffuse across the reverse-biased C-B junction into the p-type material (collector). The reason for the relative ease with which the majority carriers can cross the reverse-biased C-B junction is easily understood if we consider that for the reverse-biased diode the injected majority carriers will appear as minority carriers in the n-type base region material. Combining this with the fact that all the minority carriers in the depletion region will cross the reverse-biased junction of a diode accounts for the flow indicated in Fig. 8-2.

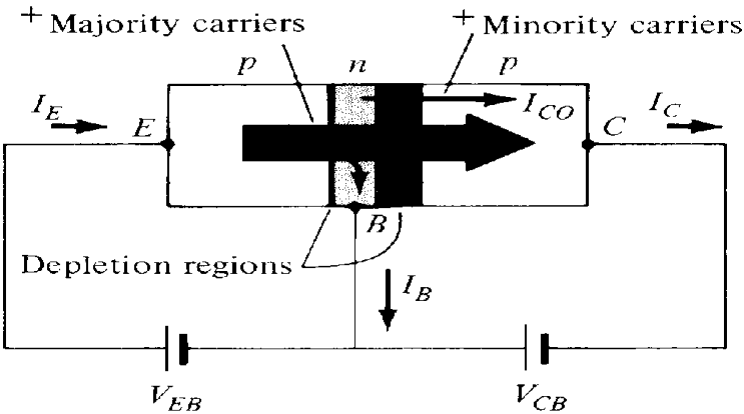

Fig. 8-2

Applying Kirchhoff's current law to the transistor of Fig. 8-2, we obtain

$$\boxed{I_E = I_C + I_B} \quad [8.1]$$

The collector current, however, is comprised of two components: the majority and minority carriers as indicated in Fig. 8-2. The minority-current component is called the **leakage current** and is given the symbol  $I_{CO}$  ( $I_C$  current with emitter terminal Open). The collector current, therefore, is determined in total by Eq. [8.2].

$$I_C = I_C \text{ majority} + I_{CO} \text{ minority} \quad [8.2]$$

## Common-Base (CB) Configuration:

The common-base configuration with npn and pnp transistors are indicated in Fig. 8-3. The common-base terminology is derived from the fact that the base is common to both input and output sides of the configuration. In addition, the base is usually terminal closest to, or at, the ground potential.

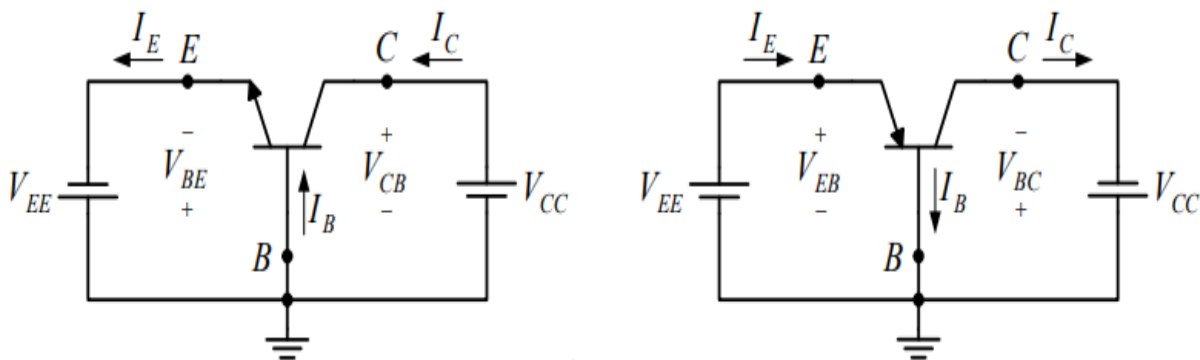

Fig. 8-3

In the dc mode the levels of  $I_C$  and  $I_E$  due to the majority carriers are related by a quantity called **alpha** ( $\alpha_{dc}$ ) and defined by the following equation:

$$\boxed{\alpha_{dc} = \frac{I_C}{I_E}} \quad [8.3]$$

Where  $I_C$  and  $I_E$  are the levels of current at the point of operation and  $\alpha_{dc} \approx 1$ , or for practical devices:  $0.900 \leq \alpha_{dc} \leq 0.998$ .

Since alpha is defined solely for the majority carriers and from Fig. 8-4, Eq. [8.2] becomes

$$\boxed{I_C = \alpha I_E + I_{CBO}} \quad [8.4]$$

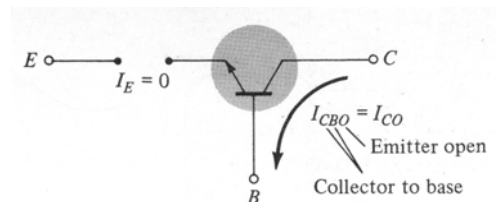

Fig. 8-4

The input (emitter) characteristics for a CB configuration are a plot of the emitter (input) current ( $I_E$ ) versus the base-to-emitter (input) voltage ( $V_{BE}$ ) for a range of values of the collector- to-base (output) voltage ( $V_{CB}$ ) as shown in Fig. 8-5. Since, the exact shape of this  $I_E$ - $V_{BE}$  curve will depend on the reverse-biasing output voltage,  $V_{CB}$ . The reason for this dependency is that the greater the value of  $V_{CB}$ , the more readily minority carriers in the base are swept through the C-B junction. The increase in emitter-to-collector current resulting from an increase in  $V_{CB}$  means the emitter current will be greater for a given value of base-to-emitter voltage ( $V_{BE}$ ).

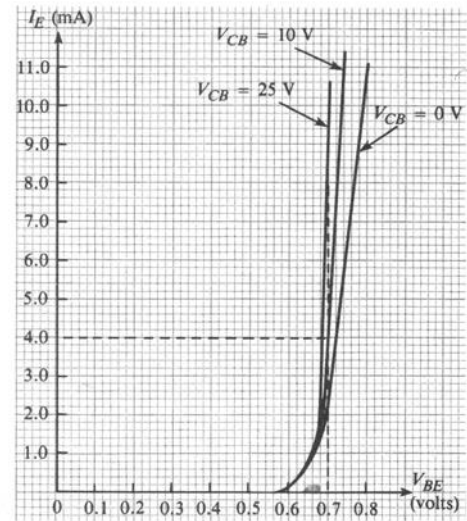
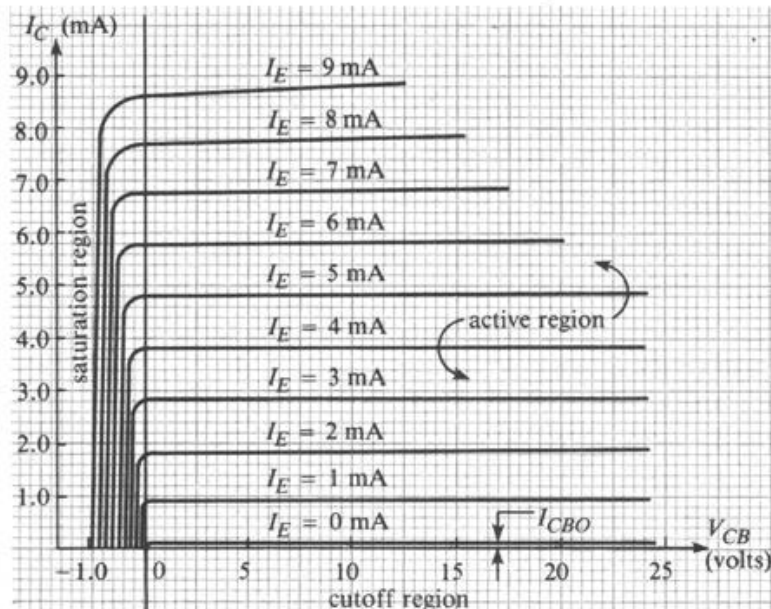

Fig. 8-5



The output (collector) characteristics for CB configuration will be a plot of the collector (output) current ( $I_C$ ) versus collector-to-base (output) voltage ( $V_{CB}$ ) for a range of values of emitter (input) current ( $I_E$ ) as shown in Fig. 8-6. The collector characteristics have three basic region of interest, as indicated in Fig. 8-6, the active, cutoff, and saturation regions.

Active region:

$$V_{CB} > 0 \text{ and } I_C = \alpha I_E .$$

Cutoff region:

$$I_E = 0 \quad I_C = I_{CBO} .$$

and

Saturation region:

$$V_{CB} < 0 \quad I_C (sat.) \approx I_E (sat.) .$$

and

For ac situations where the point of operation moves on the characteristic curve, an ac alpha ( $\alpha_{ac}$ ) is defined by

$$\alpha_{ac} = \left. \frac{\Delta I_C}{\Delta I_E} \right|_{V_{CB} = \text{const.}} \quad [8.5]$$

The ac alpha is formally called the *common-base, short-circuit, amplification factor*, and for most situations the magnitudes of  $\alpha_{ac}$  and  $\alpha_{dc}$  are quite close, permitting the use of the magnitude of one for other.

Fig. 8-7 shows how the common-base output characteristics appear when the effects of breakdown are included. Note the sudden upward swing of each curve at a large value of  $V_{CB}$ . The collector-to-base breakdown voltage when  $I_E = 0$  (emitter open) is designated  $BV_{CBO}$ .

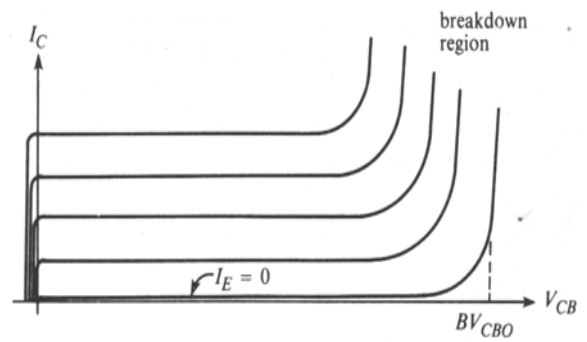

### Transistor Amplification Action:

The basic voltage-amplifying action of the CB configuration can now be described using the circuit of Fig. 8-8. The dc biasing does not appear in the figure since our interest will be limited to the ac response. For the CB configuration, the input resistance between the emitter and the base of a transistor will typically vary from 10 to 100  $\Omega$ , while the output resistance may vary from 100 k $\Omega$  to 1 M $\Omega$ . The difference in resistance is due to the forward-biased junction at the input (base to emitter) and the reverse-biased junction at the output (base to collector). Using effective values and a common value of 20  $\Omega$  for the input resistance, we find that



$$10mA. = 200mV / 20 = V_i / R_i = I_i$$

If we assume for the moment that

$$\alpha_{ac} = 1 (I_c = I_e),$$

$$I_L = I_i = 10mA$$

and  $V_L = I_L R = (10mA)(5k\Omega) = 50V .$

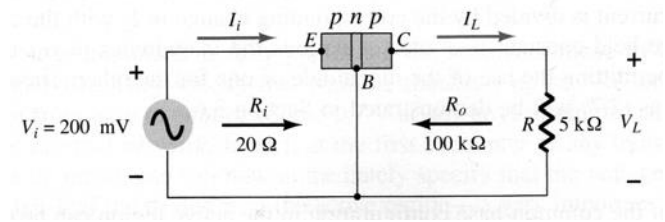

Fig. 8-8

The voltage amplification is

$$A_v = V_L / V_i = 50V / 200mV = 250.$$

Typical values of voltage amplification for the common-base configuration vary from 50 to 300. The current amplification ( $I_C/I_E$ ) is always less than 1 for the CB configuration. This latter characteristic should be obvious since  $I_C = \alpha I_E$  and  $\alpha$  is always less than 1.

The basic amplifying action was produced by *transferring* a current  $I$  from a low- to a high-*resistance* circuit. The combination of the two terms in italics results in the label transistor; that is, *transfer* + *resistor* → *transistor*.

### Common-Emitter (CE) Configuration:

The common-emitter configuration with npn and pnp transistors are indicated in Fig. 8-9. The external voltage source  $V_{BB}$  is used to forward bias the E-B junction and the external voltage source  $V_{CC}$  is used to reverse bias C-B junction. The magnitude of  $V_{CC}$  must be greater than  $V_{BB}$  to ensure the C-B junction remains reverse biased, since, as can be seen in the Fig. 8-9,  $V_{CB} = V_{CC} - V_{BB}$ .

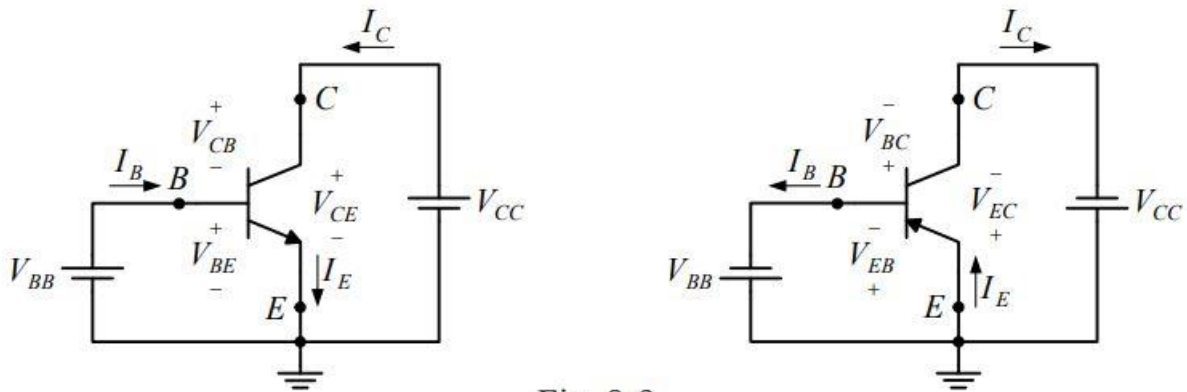

Fig. 8-9

From Eqs. [8.1] and [8.4], we obtain

$$I_C = \alpha(I_C + I_B) + I_{CBO}$$

Rearranging yields

$$I_C = \frac{\alpha I_B}{1 - \alpha} + \frac{I_{CBO}}{1 - \alpha} \quad [8.6]$$

From Fig. 8-10, Eq. [8.6] becomes

$$I_{CEO} = \frac{I_{CBO}}{1 - \alpha} \Big|_{I_B=0} \quad [8.7]$$

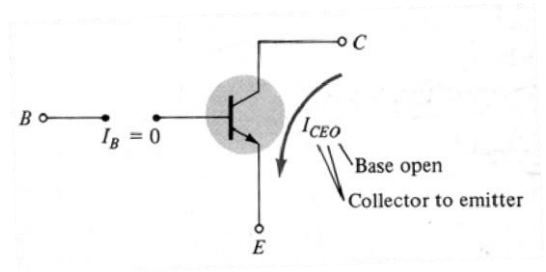

Fig. 8-10

In the dc mode the levels of  $I_C$  and  $I_B$  are related by a quantity called **beta** ( $\beta_{dc}$ ) and defined by the following equation:

$$\beta_{dc} = \frac{I_C}{I_B} \quad [8.8]$$

Where  $I_C$  and  $I_B$  are the levels of current at the point of operation. For practical devices the levels of  $\beta_{dc}$

typically ranges from about 50 to over 500, with most in the mid range. On specification sheets  $\beta_{dc}$  is usually included as  $h_{FE}$  with  $h$  derived from an ac hybrid equivalent circuit.

For ac situation an ac beta ( $\beta_{ac}$ ) has been defined as follows:

$$\beta_{ac} = \frac{\Delta I_C}{\Delta I_B} \bigg|_{V_{CE}=\text{const.}} \quad [8.9]$$

The formal name for  $\beta_{ac}$  is *common-emitter, forward-current, amplification factor* and on specification sheets  $\beta_{ac}$  is usually included as  $h_{fe}$ .

A relationship can be developed between  $\beta$  and  $\alpha$  introduced thus far. Using  $\beta = I_C / I_B$  we have  $I_B = I_C / \beta$ . We have  $I_E = I_C / \alpha$ . Substituting into  $I_E = I_C + I_B$  we have  $I_C / \alpha = I_C + I_C / \beta$ . Dividing both sides of the equation by  $I_C$  will give  $1/\alpha = 1 + 1/\beta$  so that  $\beta = \alpha\beta + \alpha = (\beta + 1)\alpha$  so that

$$\alpha = \frac{\beta}{\beta + 1} \quad \text{or} \quad \beta = \frac{\alpha}{1 - \alpha} \quad [8.10]$$

In addition, recall that  $I_{CEO} = I_{CBO} / (1 - \alpha)$  and  $1/(1 - \alpha) = \beta + 1$  derived from the above, we find that  $I_{CEO} = (\beta + 1)I_{CBO}$

$$I_{CEO} \cong \beta I_{CBO} \quad [8.11]$$

Beta is particularly important parameter because it relates the current levels of the input and output circuits for CE configuration.

$$I_C = \beta I_B + I_{CEO} \approx \beta I_B \quad [8.12]$$

and since  $I_E = I_C + I_B = \beta I_B + I_B$  we have

$$I_E = (\beta + 1)I_B \quad [8.13]$$

The input (base) characteristics for the CE configuration are a plot of the base (input) current ( $I_B$ ) versus the base-to-emitter (input) voltage ( $V_{BE}$ ) for a range of values of collector-to-emitter (output) voltage ( $V_{CE}$ ) as shown in Fig. 8-11. Note that  $I_B$  increases as  $V_{CE}$  decreases, for a fixed value of  $V_{BE}$ . A large value of  $V_{CE}$  results in a large reverse bias of the C-B junction, which widens the depletion region and makes the base smaller. When the base is smaller, there are fewer recombination's of injected minority carriers and there is a corresponding reduction in base current ( $I_B$ ).

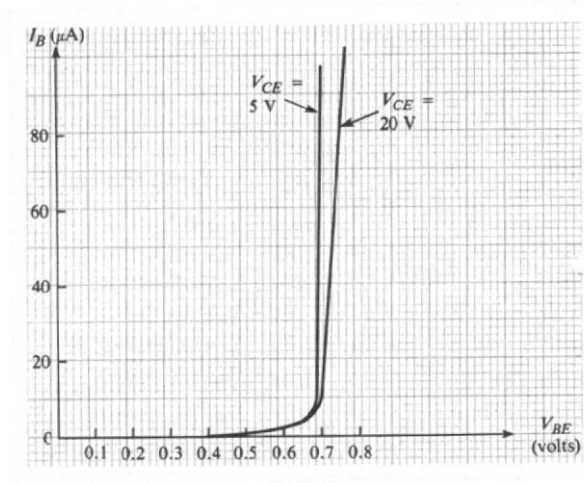

Fig. 8-11

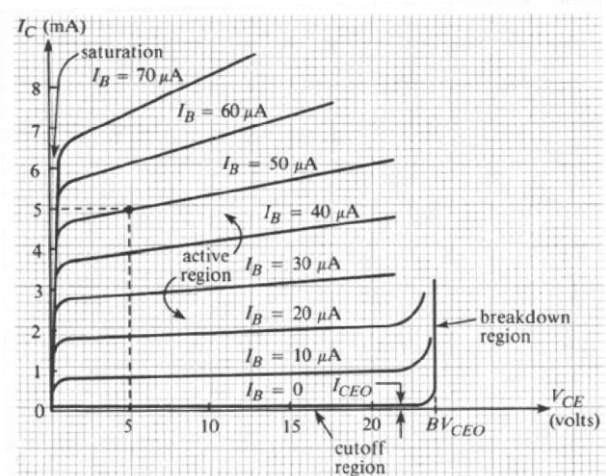

Fig. 8-12

The output (collector) characteristics for CE configuration are a plot of the collector (output) current ( $I_C$ ) versus collector-to-emitter (output) voltage ( $V_{CE}$ ) for a range of values of base (input) current ( $I_B$ ) as shown in Fig. 8-12. The collector characteristics have three basic region of interest, as indicated in Fig. 8-12, the active, cutoff, and saturation regions.

- ◀ Active region:  $I_B > 0$  &  $I_C = \beta I_B$  .
- ◀ Cutoff region:  $I_B = 0$  &  $I_C = I_{CEO}$
- ◀ Saturation region:  $V_{CE} \approx 0$  &  $I_{B(sat.)} = I_{C(sat.)} / \beta$  .

## Common-Collector (CC) Configuration:

The third and final transistor configuration is the common-collector configuration, shown in Fig. 8-13 with npn and pnp transistors. The CC configuration is used primarily for impedance-matching purposes since it has a high input impedance and low output impedance, opposite to that which is true of the common-base and common-emitter configurations.

From a design viewpoint, there is no need for a set of common-collector characteristics to choose the circuit parameters. The circuit can be designed using the common-emitter characteristics. For all practical purposes, the output characteristics of the CC configuration are the same as for the CE configuration. For the CC configuration the output characteristics are a plot of emitter (output) current ( $I_E$ ) versus collector-to-emitter (output) voltage ( $V_{CE}$ ), for a range of values of base (input) current ( $I_B$ ). The output current, therefore, is the same for both the common-emitter and common-collector characteristics. There is an almost unnoticeable change in the vertical scale of  $I_C$  of the common-emitter characteristics if  $I_C$  is replaced by  $I_E$  for the common-collector characteristics (since  $\alpha \approx 1$ ,  $I_E \approx I_C$ ).

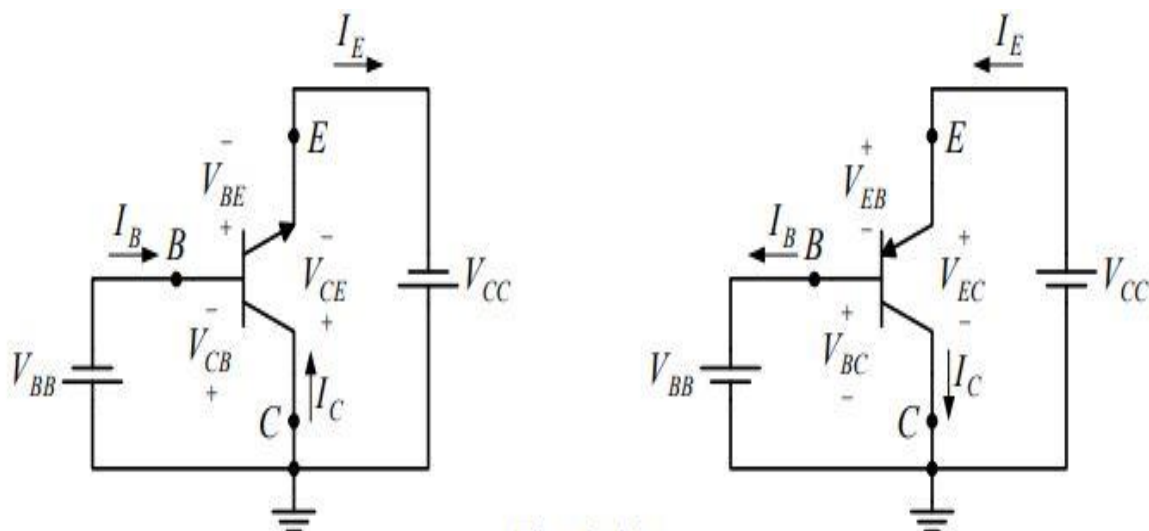
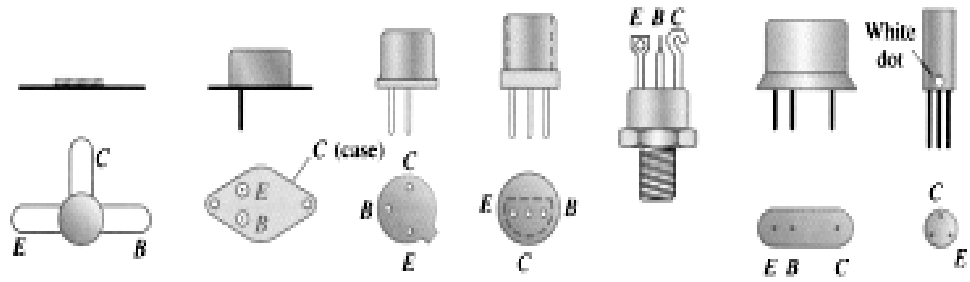

Fig. 8-13

## Transistor Casing and Terminal Identification:

Whenever possible, the transistor casing will have some marking to indicate which leads are connected to the emitter, collector, or base of a transistor. A few of the methods commonly used are indicated in Fig. 8-14.



## Exercises

1. Given an  $\alpha_{dc}$  of 0.998, determine  $I_C$  if  $I_E = 4$  mA.
  2. Determine  $\alpha_{dc}$  if  $I_E = 2.8$  mA and  $I_B = 20$   $\mu$ A.
  3. Find  $I_E$  if  $I_B = 40$   $\mu$ A and  $\alpha_{dc}$  is 0.98.
  4. Given that  $\alpha_{dc} = 0.987$ , determine the corresponding value of  $\beta$ .
  5. Given  $\beta_{dc} = 120$ , determine the corresponding value of  $\alpha$ .
  6. Given that  $\beta_{dc} = 180$  and  $I_C = 2.0$  mA, find  $I_E$  and  $I_B$ .
1. transistor has  $I_{CBO} = 48$  nA and  $\alpha = 0.992$ .
    - i.  $\beta$  and  $I_{CEO}$ .
    - ii. its (exact) collector current ( $I_C$ ) when  $I_B = 30$   $\mu$ A.
    - iii. the approximate collector current, neglecting leakage current.