



AL MUSTAQBAL UNIVERSITY COLLEGE



STUDENT NAME:	
TUTOR NAME:	Dr. Ameer Al-khaykan
PROGRAMME:	Electrical Circuit
SUBJECT:	Electrical and Electronics
COURSEWORK TITLE:	Full Wave Rectifier Circuit

Issue Date:	Due Date:	Feedback Date:	Extension Date:
--------------------	------------------	-----------------------	------------------------

PERFORMANCE CRITERIA:

TARGETED LEARNING OUTCOMES

4. Solve problems involving basic analogue and digital electronic circuits using numerical skills appropriate to an engineer.
5. Identify and safely use standard laboratory equipment to extract data, then apply in the solution of an electronic or electrical engineering problem;
6. Adopt a logical approach to the solution of engineering problems.

Important Information – Please Read Before Completing Your Work

All students should submit their work by the date specified using the procedures specified in the Student Handbook. An assessment that has been handed in after this deadline will be marked initially as if it had been handed in on time, but the Board of Examiners will normally apply a lateness penalty.

Your attention is drawn to the Section on Academic Misconduct in the *Student's Handbook*.

All work will be considered as individual unless collaboration is specifically requested, in which case this should be explicitly acknowledged by the student within their submitted material.

Any queries that you may have on the requirements of this assessment should be e-mailed to

ameer.alkhaykan@mustaqbal-college.edu.iq

No queries will be answered after respective submission dates.

You must ensure you retain a copy of your completed work prior to submission.

MARKING CRITERIA

COURSEWORK WILL BE MARKED ACCORDING TO THE FOLLOWING UNIVERSITY CRITERIA.

90-100%: a range of marks consistent with a first where the work is exceptional in all areas;

80-89%: a range of marks consistent with a first where the work is exceptional in most areas.

70-79%: a range of marks consistent with a first. Work which shows excellent content, organisation and presentation, reasoning and originality; evidence of independent reading and thinking and a clear and authoritative grasp of theoretical positions; ability to sustain an argument, to think analytically and/or critically and to synthesise material effectively.

60-69%: a range of marks consistent with an upper second. Well-organised and lucid coverage of the main points in an answer; intelligent interpretation and confident use of evidence, examples and references; clear evidence of critical judgement in selecting, ordering and analysing content; demonstrates some ability to synthesise material and to construct responses, which reveal insight and may offer some originality.

50-59%: a range of marks consistent with lower second; shows a grasp of the main issues and uses relevant materials in a generally business-like approach, restricted evidence of additional reading; possible unevenness in structure of answers and failure to understand the more subtle points: some critical analysis and a modest degree of insight should be present.

40-49%: a range of marks which is consistent with third class; demonstrates limited understanding with no enrichment of the basic course material presented in classes; superficial lines of argument and muddled presentation; little or no attempt to relate issues to a broader framework; lower end of the range equates to a minimum falls short in one or more areas.

35-39%: achieves many of the learning outcomes required for a mark of 40% but falls short in one or more areas.

30-34%: a fail; may achieve some learning outcomes but falls short in most areas; shows considerable lack of understanding of basic course material and little evidence of research.

0-29%: a fail; basic factual errors of considerable magnitude showing little understanding of basic course material; falls substantially short of the learning outcomes for compensation.

Note:

- While constructing circuits all connects should be made with the power supply in the off position.
- Check power and ground connections (and other connections) **before** switch on the power.
- Make sure that the power and the ground are properly connected to all IC's before switch on the power.
- **DO NOT** strip wire ends longer than 1/4" and jam long bare ends into the breadboard holes. This will cause shorts and ruin the board.
- **DO NOT** short (connect) the power supply outputs together, i.e., do not allow the exposed wires to touch each other. This will cause permanent damage to the power supply.
- **DO NOT** connect the power supply to the breadboard with reverse polarity. This will cause the permanent chip damage.

• **DO NOT** connect an output of any gate to the output of another gate, to a switch, to power (+5V), or to ground. These situations will cause excessive currents and result in the permanent damage to the chip or chips involved.

1. Objects:

2. To become familiar in the connection of the rectifying circuits.
3. Study the response of using diodes on the AC input signal and draw out the output response with the rectifying signal.
4. Study the three type of the rectifying circuit; half wave, full wave with bridge and center tapped rectifier circuits.
5. Use the Oscilloscope to show the output response of circuits.

2. Theory:

Full wave rectifier

The first type of full-wave rectifier shown in figure(5)is the full-wave bridge rectifiers, this type of rectifiers passes the positive (or negative) half cycle of the AC signal that and block the negative (or positive) half cycle of this AC signal .The output waveform of this type of rectifier is shown in figure (6).

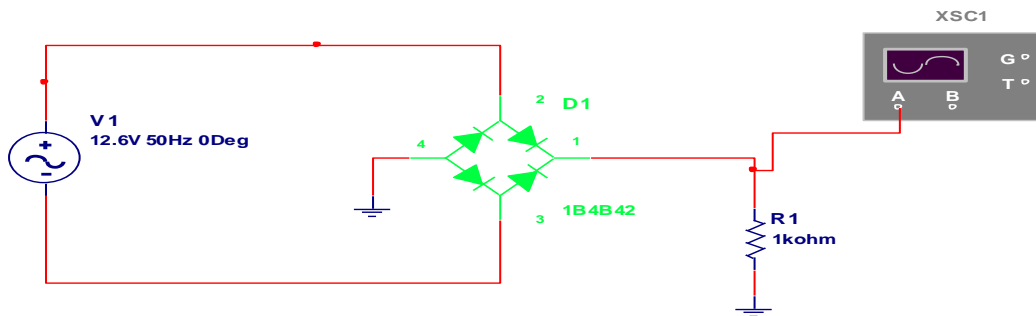

Figure (5): The full wave rectifier circuit (Bridge rectifier)

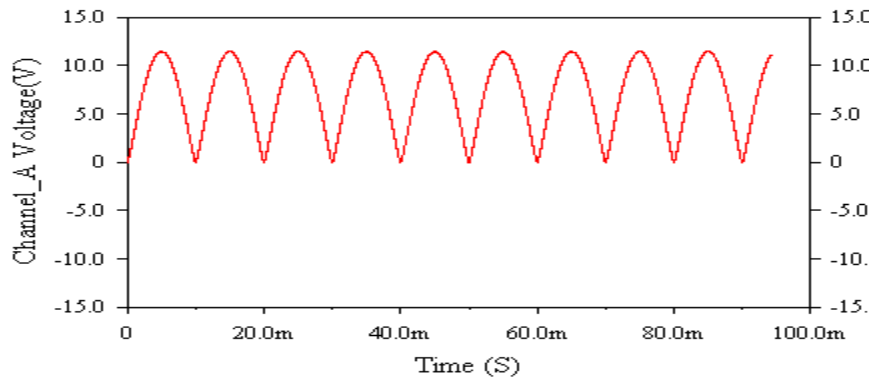

Figure (6): The output voltage waveform of the full wave rectifier circuit (Bridge rectifier)

Full-wave rectifier:

Bridge Rectifier:

- Ideal dc voltage output $=2VP/\pi$
- Diode PIV $=2VP$
- Output frequency $=2 \times$ input frequency

The second type of full wave rectifier circuit shown in figure (7) is the

center-tapped full-wave rectifiers, this type of rectifiers passes the positive (or negative) half cycle of the AC signal and block the negative (or positive) half cycle of this AC signal, The output waveform of this type of rectifier shown in figure (8).

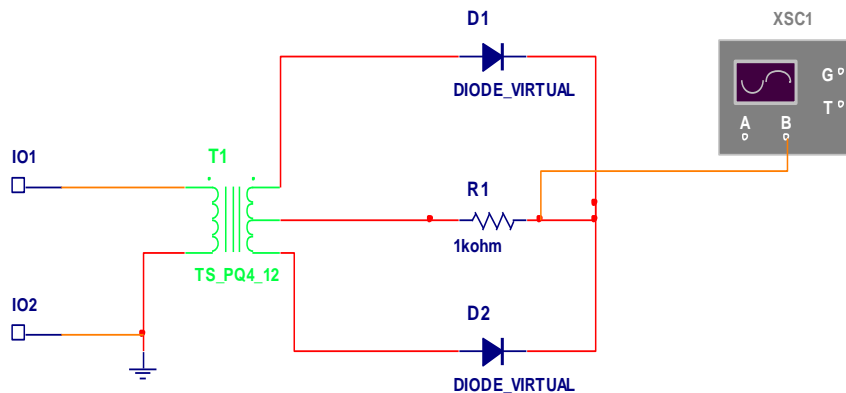

Figure (7): The center-tapped full wave rectifier circuit

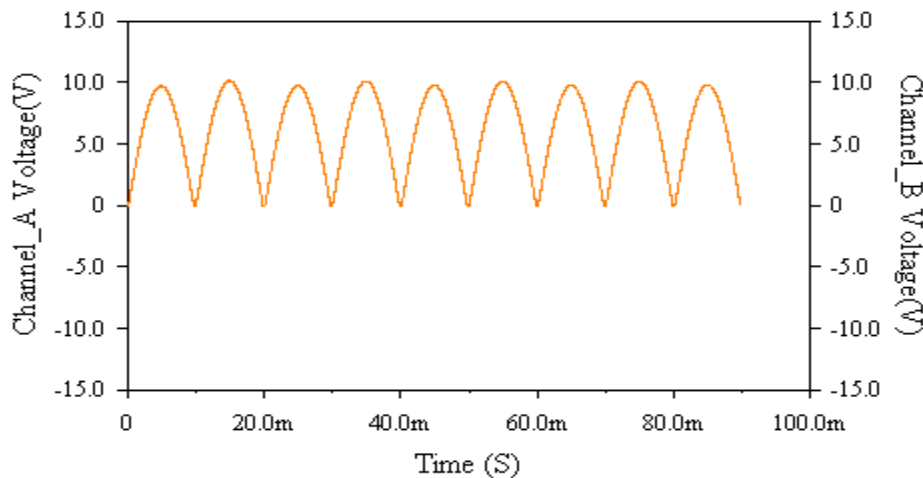

Figure (8): The output voltage waveform of the center-tapped full wave rectifier

Full-wave rectifier:

Center-tapped Rectifier:

- Ideal dc voltage output $=2V_P/\pi$
- Diode PIV $=V_P$
- Output frequency $=2\times$ input frequency

Procedure

Part 1: The full-wave bridge rectifier.

1. Connect the full-wave bridge rectifier shown in figure (5) keep in mind the polarity of the diodes used in the rectifier.
2. Measure the input and the output voltages by connect the oscilloscope at the input and output terminal of the circuit in figure (5), then record your results.
3. Using voltmeter, measures the DC voltage (VDC) across the $1k\Omega$ resistor, and then records your results.

Part 2: The center-tapped full-wave rectifier.

1. Connect the center-tapped full-wave rectifier Circuit shown in figure (7) keep in mind the polarity of the diodes used in the rectifier.
2. Measure the input and the output voltages by connect the oscilloscope at the input terminal of the circuit to measure the input, and the terminals of the load resistor to measure the output voltage and sketch the output waveform as shown in figure (8), then record your results.
3. Using voltmeter, measures the DC voltage (VDC) across the $1k\Omega$ resistor, and then records your result.

Equipment's:

1. $1k\Omega$ resistor.
2. 4(1N4001) silicon rectifier diodes.
3. Center tapped transformer.
4. Oscilloscope.
5. Voltmeter

Function generator

Discussion

1. Explain the action of filter (capacitor); what is the effect of changing the value of the capacitor on the ripple value or the ripple factor?
2. Compare between the half wave and the full wave rectifier circuits.
3. Give some applications of the rectifier circuits.
4. Compare between the frequencies of the input and the output voltages of (a) a half – wave rectifier (b) a full-wave rectifier.

2.6 Review Questions

. In this experiment, the rectifier circuit that has the lowest diode peak inverse voltage is the:

- (1) full-wave center-tapped rectifier
- (2) full-wave bridge rectifier (3) both 1 and 2

- In this experiment, the rectifier circuit that has the greatest DC output voltage is the:

- (a) full-wave center-tapped rectifier
- (b) full-wave bridge rectifier