



Class :3rd stage

Subject: Thermodynamics

م.م زهراء عبد الاله هادي

م.م ايلاف جاسم محان

م.م حسن علي شمخي

مهندس احمد عباس محمد



Ministry of Higher Education and Scientific Research Al-Mustaqbal University College

Chemical engineering and petroleum industries

(Thermodynamic Lab3)

(Experiment No.4)

**Specifying the phase of the refrigerant at the beginning and
the end of the compression refrigeration cycle and
calculation thermal efficiency of the cycle**

اعداد:

م.م زهراء عبد الاله هادي

م.م ايلاف جاسم محان

م.م حسن علي شمخي

مهندس احمد عباس محمد



Class :3rd stage

Subject: Thermodynamics

م.م زهراء عبد الاله هادي

م.م ايلاف جاسم محان

م.م حسن علي شمخي

مهندس احمد عباس محمد



Name of experiment: Specifying the phase of the refrigerant at the beginning and the end of the compression refrigeration cycle and calculation thermal efficiency of the cycle

Purpose of experiment:

- 1 - Knowing the state of the refrigerant at the beginning of the refrigeration cycle (at the condenser area).
- 2- Knowing the condition of the refrigerant (at the evaporator area).
- 3- Identify the parts of the compression refrigeration cycle and the advantage of each part.
- 4- Determination the coefficient of performance of refrigeration cycle.

Equipment:

The main parts are:

1. Compressor
2. Condenser
3. Evaporator
4. Capillary tube

Other parts which are used in refrigeration cycle are:

1. Filter dryer
2. High and low temperature porting gauge
3. Sensors to compute temperature
4. Converter to compute compressor power
5. Viewing windows



Class :3rd stage

Subject: Thermodynamics

م.م زهراء عبد الاله هادي

م.م ايلاف جاسم محان

م.م حسن علي شمخي

مهندس احمد عباس محمد



Theory:

The refrigeration cycle consists of four major components: compressor, condenser, metering device, and evaporator as shown in Figure below.

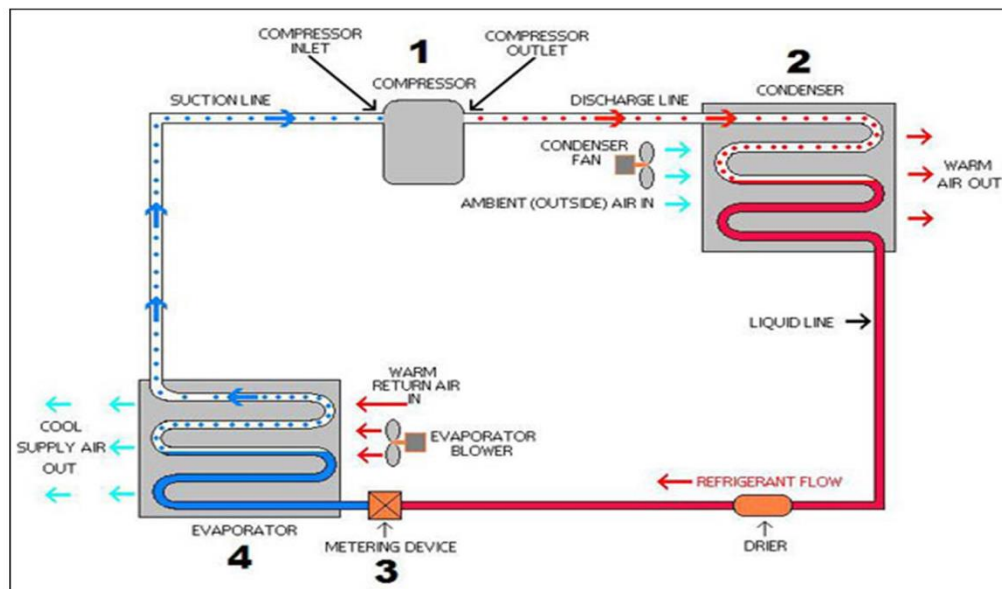

Fig: Refrigeration cycle.

The first point to understand about refrigeration theory is that heat is energy, and it can be made to move. If enough heat is removed from a glass of water, the water will freeze to ice. When that heat is allowed to move back into the ice, the ice will melt. Heat has its own laws, called the laws of thermodynamics.

One of those laws is that heat will move from a place that has a lot of heat to a place that has less heat. Another way to put it is that heat will move from a place of higher intensity to a place of lower intensity. It happens naturally, and automatically, similar to the way the north pole of a magnet is attracted to the south pole of another magnet.



Class :3rd stage

Subject: Thermodynamics

م.م زهراء عبد الاله هادي

م.م ايلاف جاسم محان

م.م حسن علي شمخي

مهندس احمد عباس محمد



So, to take advantage of this point of the theory, air conditioning and refrigeration equipment is designed to create a cold area that acts as a "heat sponge" to soak up heat from the surrounding air or food. The heat is then moved to a place where it can be released safely and efficiently.

The second main point to understand about refrigeration theory has to do with why we use evaporators and condensers.

When a liquid like water or refrigerant absorbs enough heat to start boiling, what's happening is that the added heat energy causes the vibration of the liquid's molecules to speed up to the point where they move farther apart from each other. When the molecules of liquid reach a certain distance from each other, the liquid changes into a vapor. This is called boiling, evaporating, or vaporizing.

A liquid absorbs intense levels of heat as it changes state to a vapor. Air conditioning and refrigeration equipment is designed to use this point of refrigeration theory by keeping a constant flow of refrigerant vaporizing and absorbing heat in the evaporator. So the evaporator is the "heat sponge" area, and the refrigerant vaporizing inside of it is absorbing the heat.

When vapor cools and releases enough heat energy, its molecules will slow down and move closer together to the point where the vapor changes into a liquid.

This is called condensation, and it's also a change of state (from vapor to liquid). To condense, a vapor must release the same intense level of heat that it absorbed when it vaporized.

Air conditioning and refrigeration uses this point of refrigeration theory by causing refrigerant to cool and condense in the condensing unit. One way to think of it is that the heat that the refrigerant absorbed in the evaporator or "heat sponge" area is squeezed out of the refrigerant in the condenser.

The refrigerant repeats this cycle continuously, absorbing heat in the evaporator, and releasing it out in the condenser.



Class :3rd stage

Subject: Thermodynamics

م.م زهراء عبد الاله هادي

م.م ايلاف جاسم محان

م.م حسن علي شمخي

مهندس احمد عباس محمد



Procedure

1. Fill the evaporator and condenser with water to the limit.
2. Play the device.
3. Record T_1 and T_2 .
4. Measure coefficient of performance which indicate to refrigeration cycle efficiency by using equation below:

$$\text{COP} = \frac{Q}{W}$$

Where Q is the heat removal from the system and W is the work supplied in compressor.

$$W (\text{watt}) = m \cdot C_p \Delta T$$

Where m is the mass of water, C_p is specific heat of water (4.18 Kj/Kg.K) and ΔT is temperature differences between initial and final area which water flow in.

For carnot coefficient of performance can be expressed by:

$$\text{COP} = \frac{T_1}{T_2 - T_1}$$

Where T_1 is less than T_2

Discussion and Questions:

1. Why Freon gas is used?
2. Set applications which are used this cycle in their work.
3. What are differences between evaporator and condenser?
4. What are the benefits of using filter dryer and capillary tube?