



Department of Computer Engineering Techniques (Stage: 4)

Advance Computer Technologies

Dr.: Hussein Ali Ameen

hussein_awadh@mustaqbal-college.edu.iq



The μP and its Architecture

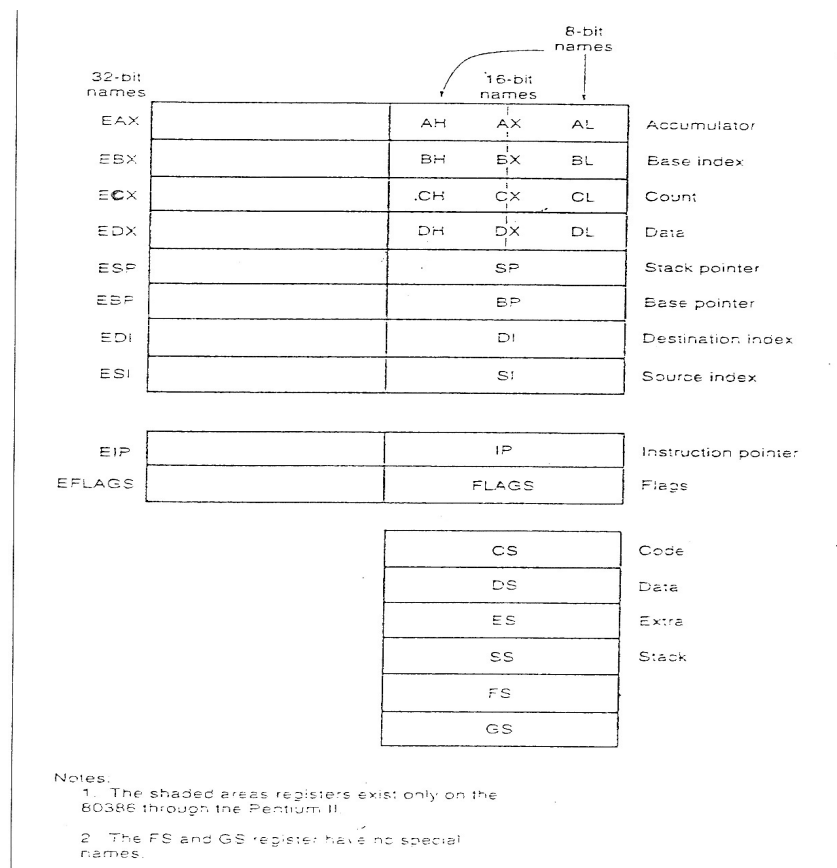



Addressing Modes

FIGURE 3–1 The MOV instruction showing the source, destination, and direction of data flow.

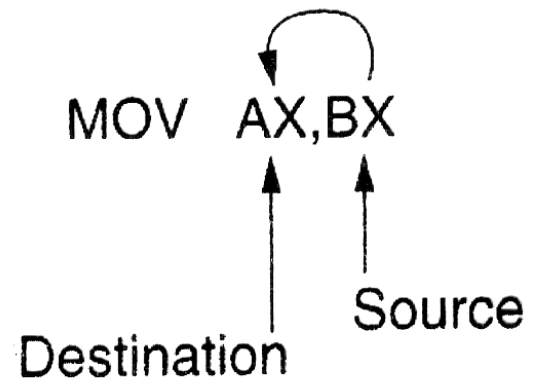



1. Register addressing
2. Immediate addressing
3. Direct addressing
4. Register indirect addressing
5. Base-plus-index addressing
6. Register relative addressing
7. Base relative-plus-index addressing
8. Scaled-index addressing



1. Register Operand Addressing Mode

MOV AX, BX

Register	Operand size		
	Byte (Reg8)	Word (Reg16)	Double word (Reg32)
Accumulator	AL, AH	AX	EAX
Base	BL, BH	BX	EBX
Count	CL, CH	CX	ECX
Data	DL, DH	DX	EDX
Stack pointer	—	SP	ESP
Base pointer	—	BP	EBP
Source index	—	SI	ESI
Destination index	—	DI	EDI
Code segment	—	CS	—
Data segment	—	DS	—
Stack segment	—	SS	—
E data segment	—	ES	—
F data segment	—	FS	—
G data segment	—	GS	—

Figure 3.7 Direct addressing registers and operand sizes.

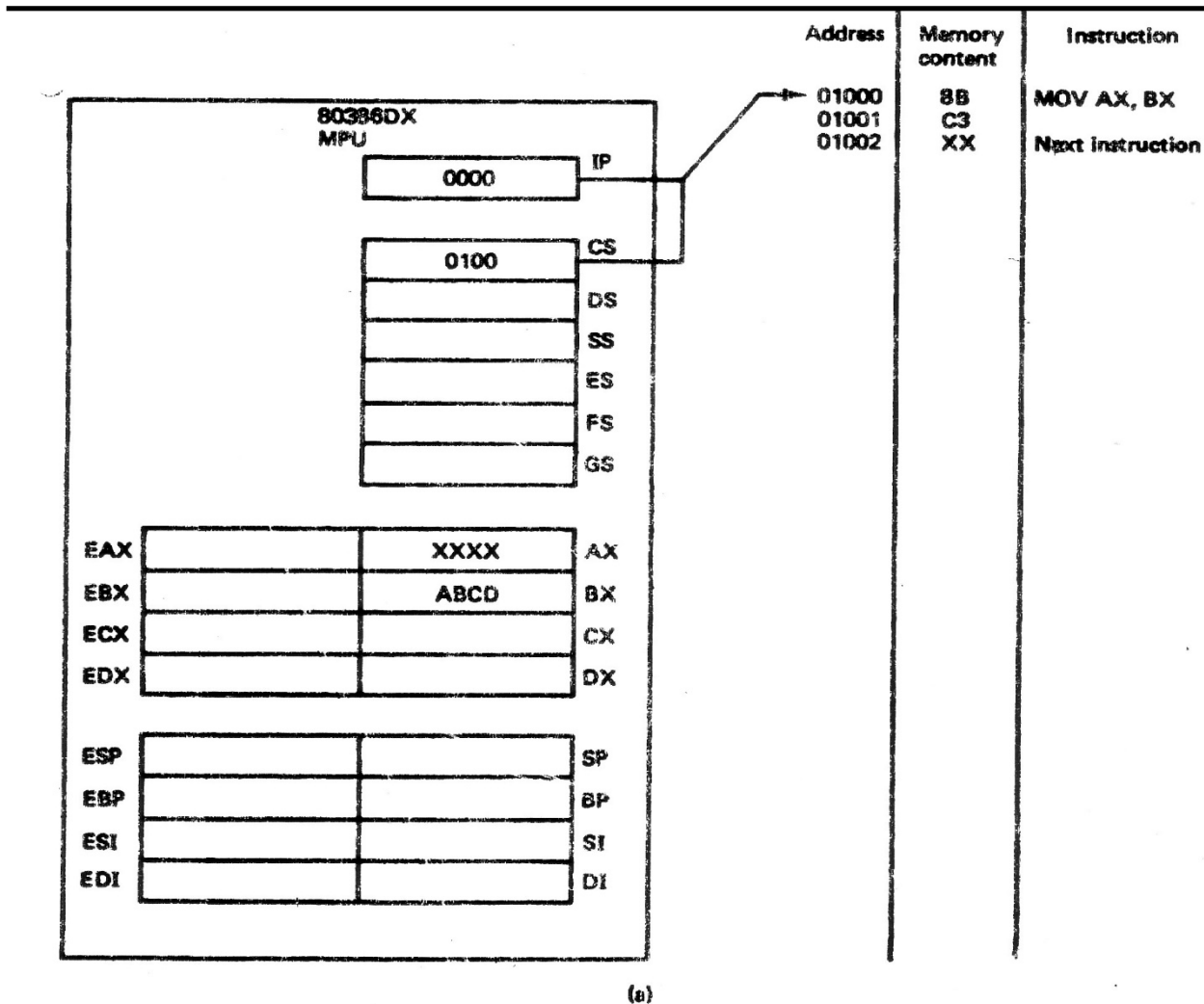
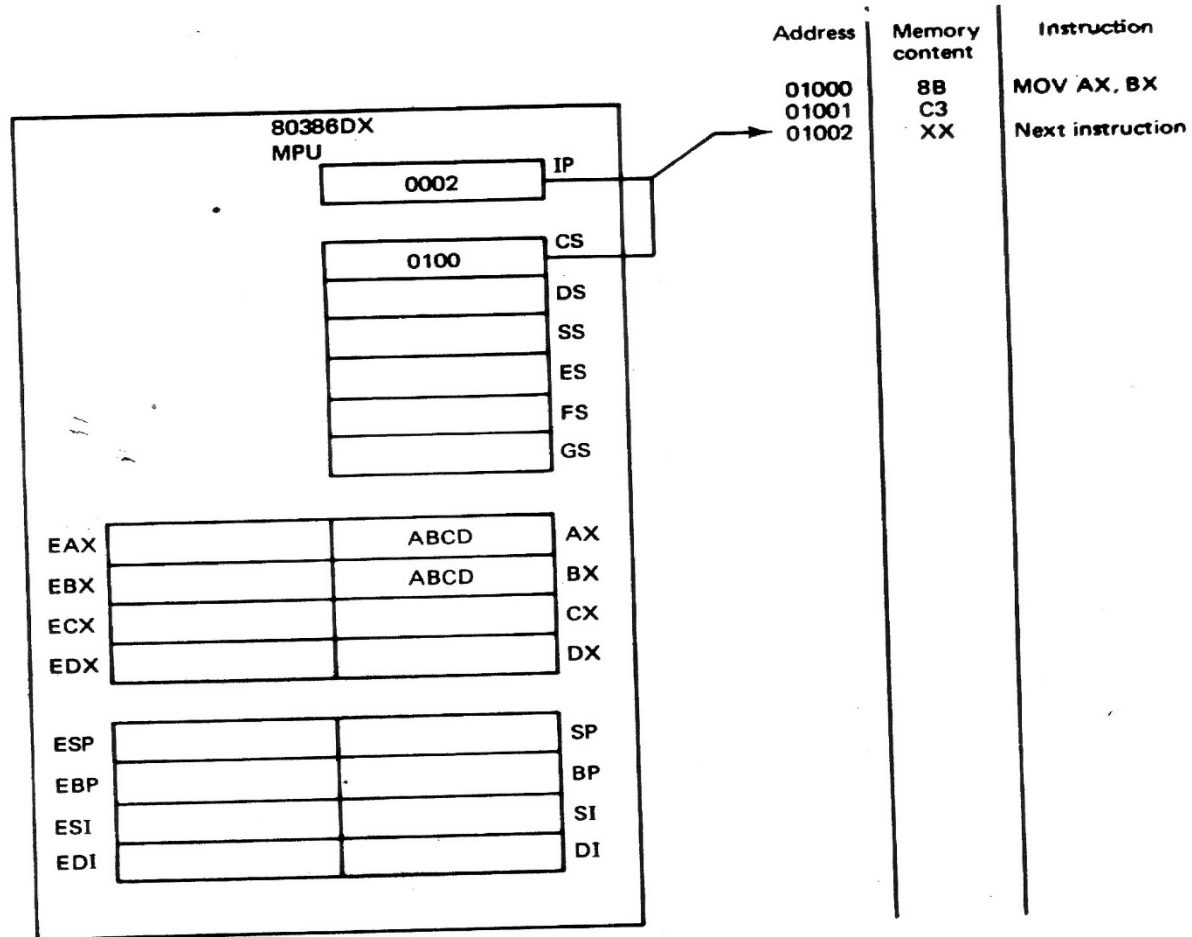

Figure 3.8 (a) Register addressing mode instruction before fetch and execution. (b) After execution.



(b)

Figure 3.8 (Continued)

2.Immediate Operand Addressing Mode

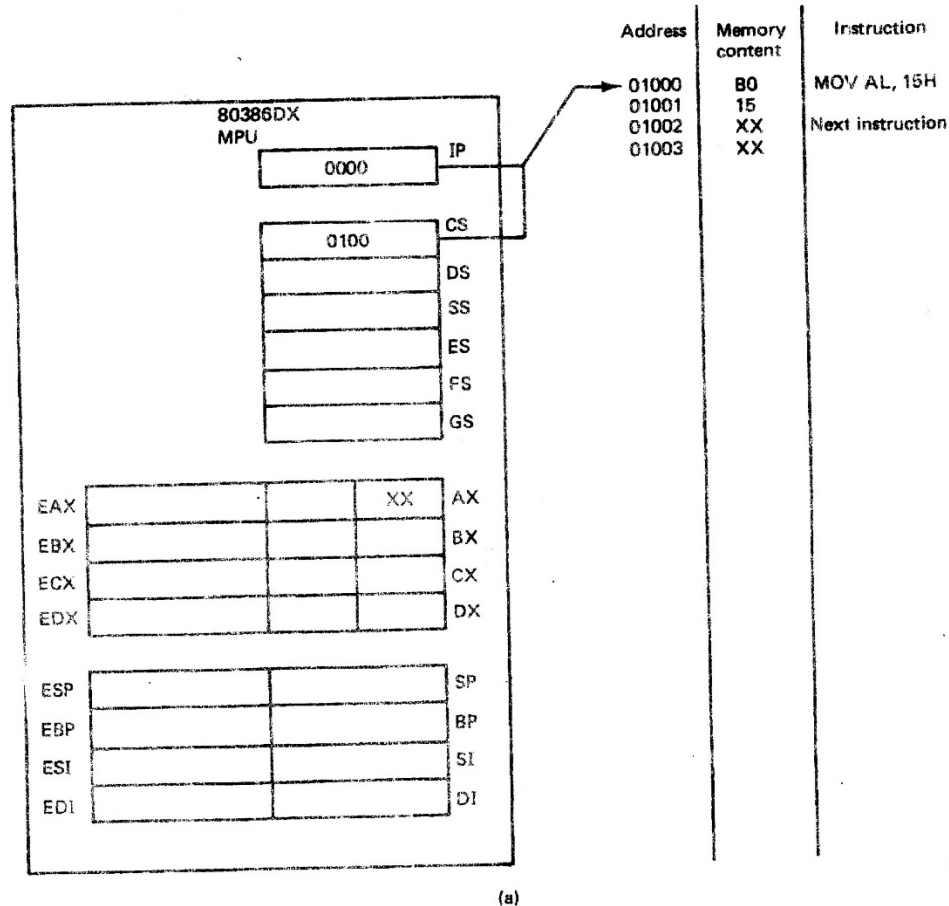
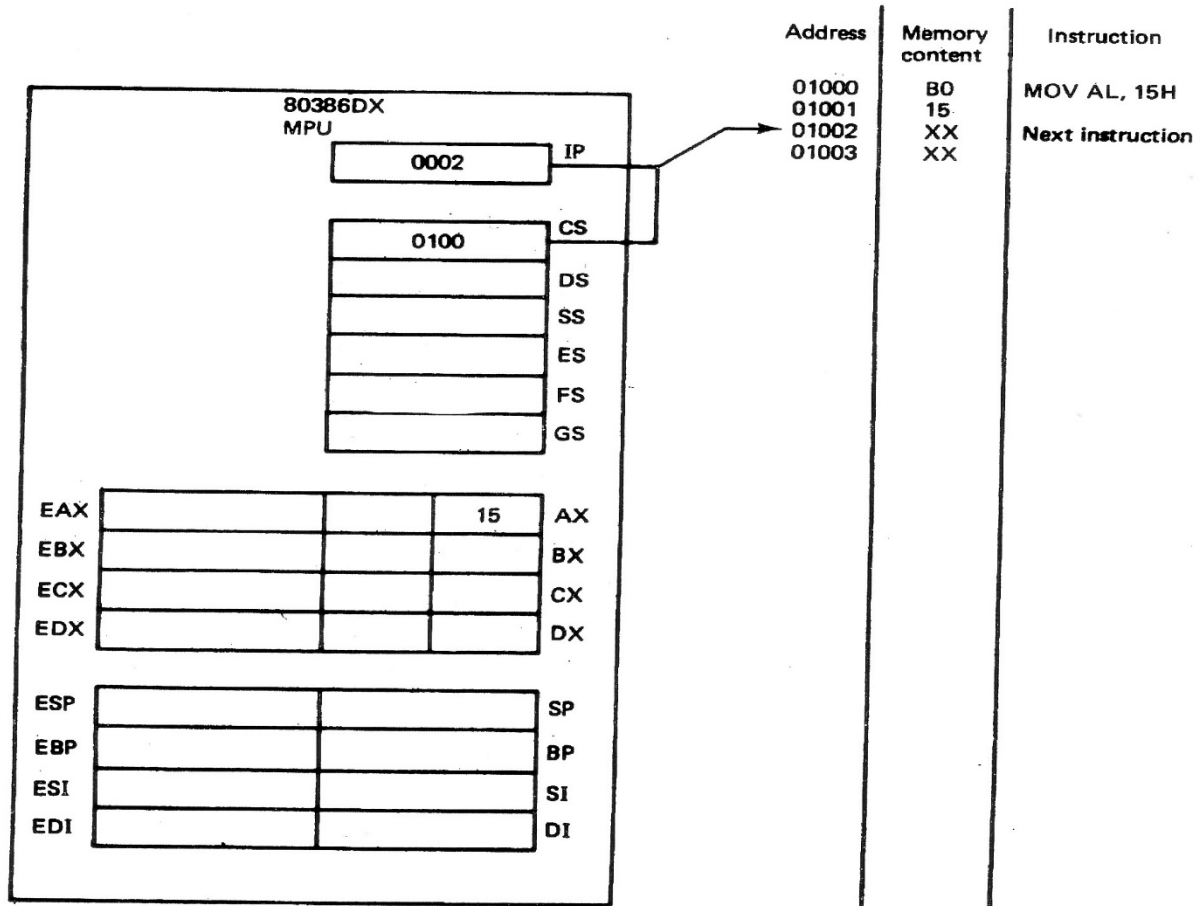

Figure 3.10 (a) Immediate addressing mode instruction before fetch and execution. (b) After execution.



(b)

Figure 3.10 (Continued)



16-Bit Memory Operand Addressing Modes

$$EA = \text{base} + \text{index} + \text{displacement}$$

$$PA = SBA : EA$$

$$PA = \text{Segment base} : \text{Base} + \text{Index} + \text{Displacement}$$

$$PA = \left\{ \begin{array}{c} CS \\ SS \\ DS \\ ES \end{array} \right\} : \left\{ \begin{array}{c} BX \\ BP \end{array} \right\} + \left\{ \begin{array}{c} SI \\ DI \end{array} \right\} + \left\{ \begin{array}{l} \text{8-bit displacement} \\ \text{16-bit displacement} \end{array} \right\}$$

3. Direct Addressing Mode

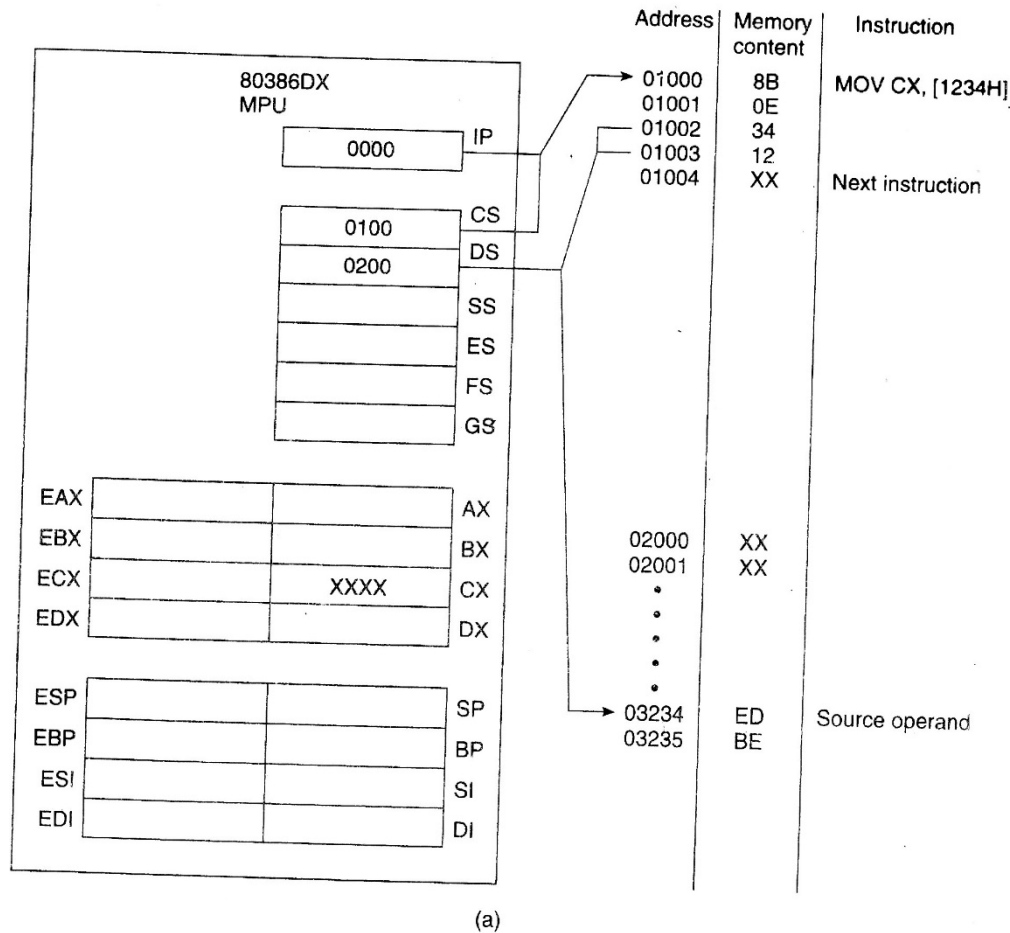
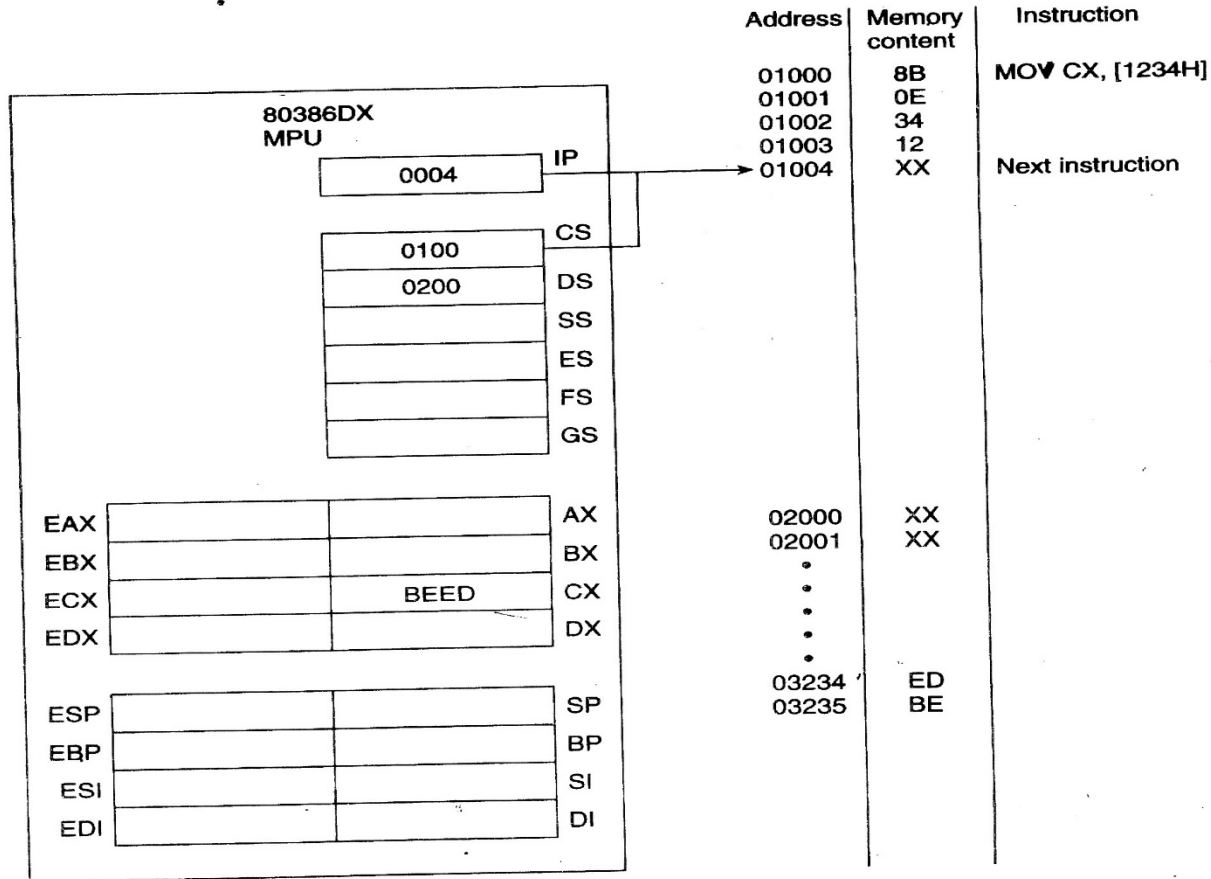

Figure 3.13 (a) Direct addressing mode instruction before fetch and execution. (b) After execution.



(b)

Figure 3.13 (Continued)



Example 1-15

Find the physical address of the memory location and its contents after the execution of the following, assuming that $DS = 1512H$.

```
MOV    AL,99H  
MOV    [3518],AL
```

Solution:

First AL is initialized to 99H, then in line two, the contents of AL are moved to logical address DS:3518 which is 1512:3518. Shifting DS left and adding it to the offset gives the physical address of 18638H ($15120H + 3518H = 18638H$). That means after the execution of the second instruction, the memory location with address 18638H will contain the value 99H.

4. Register Indirect Addressing Mode

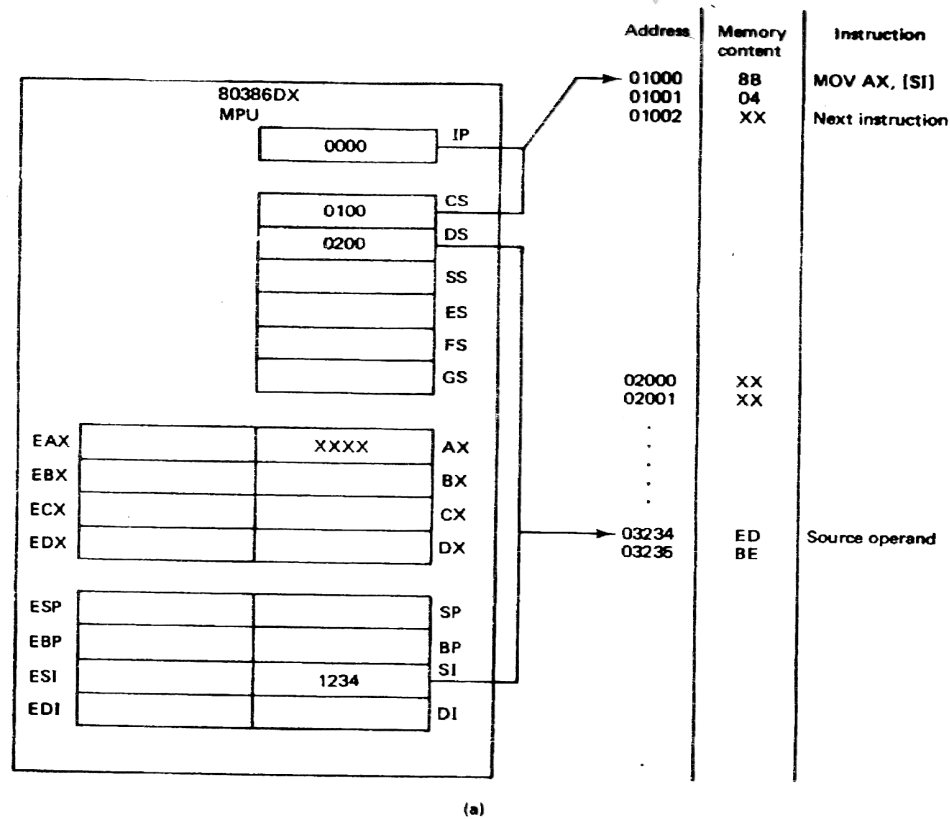
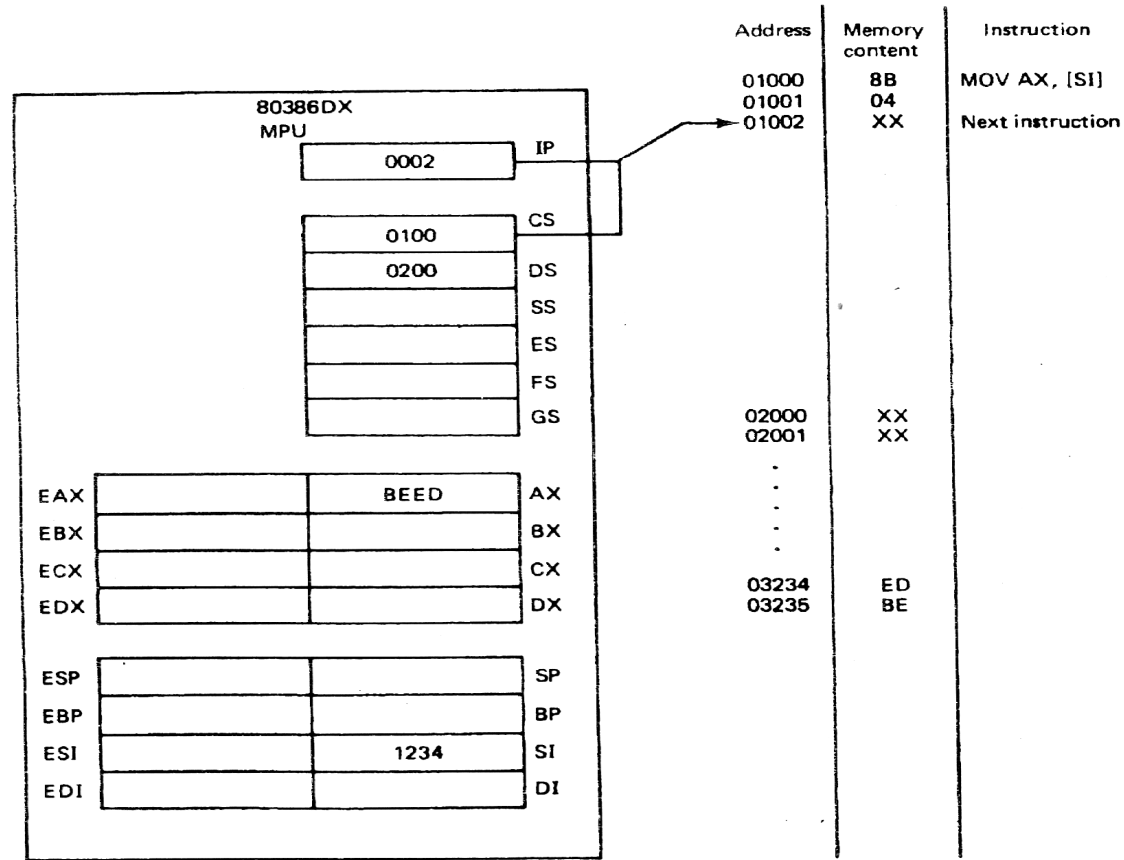

Figure 3.15 (a) Instruction using register indirect addressing mode before fetch and execution. (b) After execution.



(b)

Figure 3.15 (Continued)



Example 1-16

Assume that $DS = 1120$, $SI = 2498$, and $AX = 17FE$. Show the contents of memory locations after the execution of

```
MOV [SI],AX
```

Solution:

The contents of AX are moved into memory locations with logical address $DS:SI$ and $DS:SI + 1$; therefore, the physical address starts at DS (shifted left) + $SI = 13698$. According to the little endian convention, low address $13698H$ contains FE , the low byte, and high address $13699H$ will contain 17 , the high byte.

5. Based addressing mode

$$PA = \left\{ \begin{array}{l} CS \\ DS \\ SS \\ ES \\ FS \\ GS \end{array} \right\} : \left\{ \begin{array}{l} BX \\ BP \end{array} \right\} + \left\{ \begin{array}{l} 8\text{-bit displacement} \\ 16\text{-bit displacement} \end{array} \right\}$$

(a)

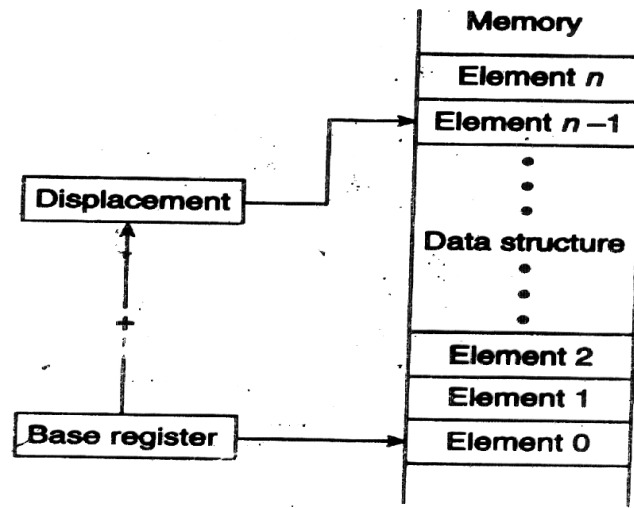

(b)

Figure 3.16 (a) Computation of a based address. (b) Based addressing of a structure of data.

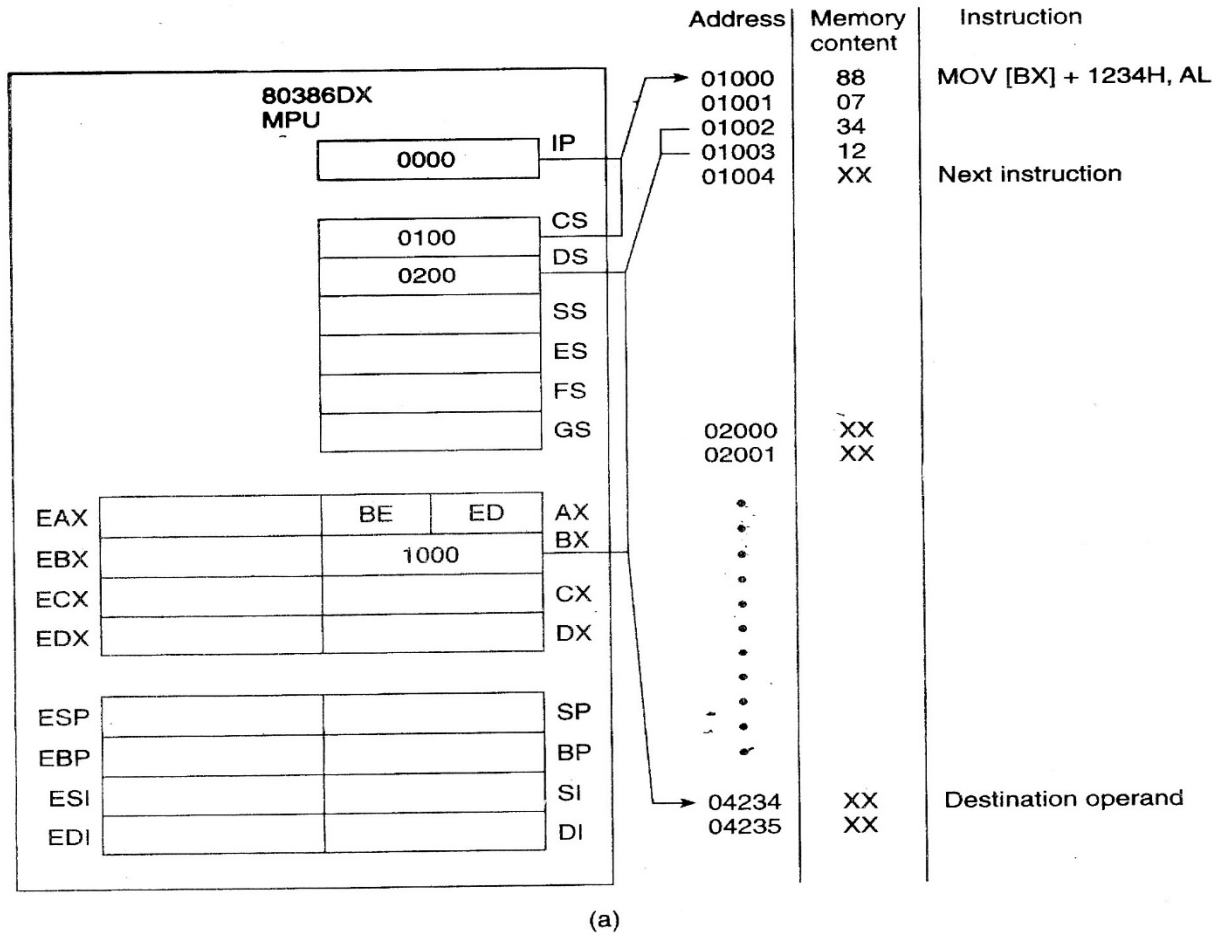
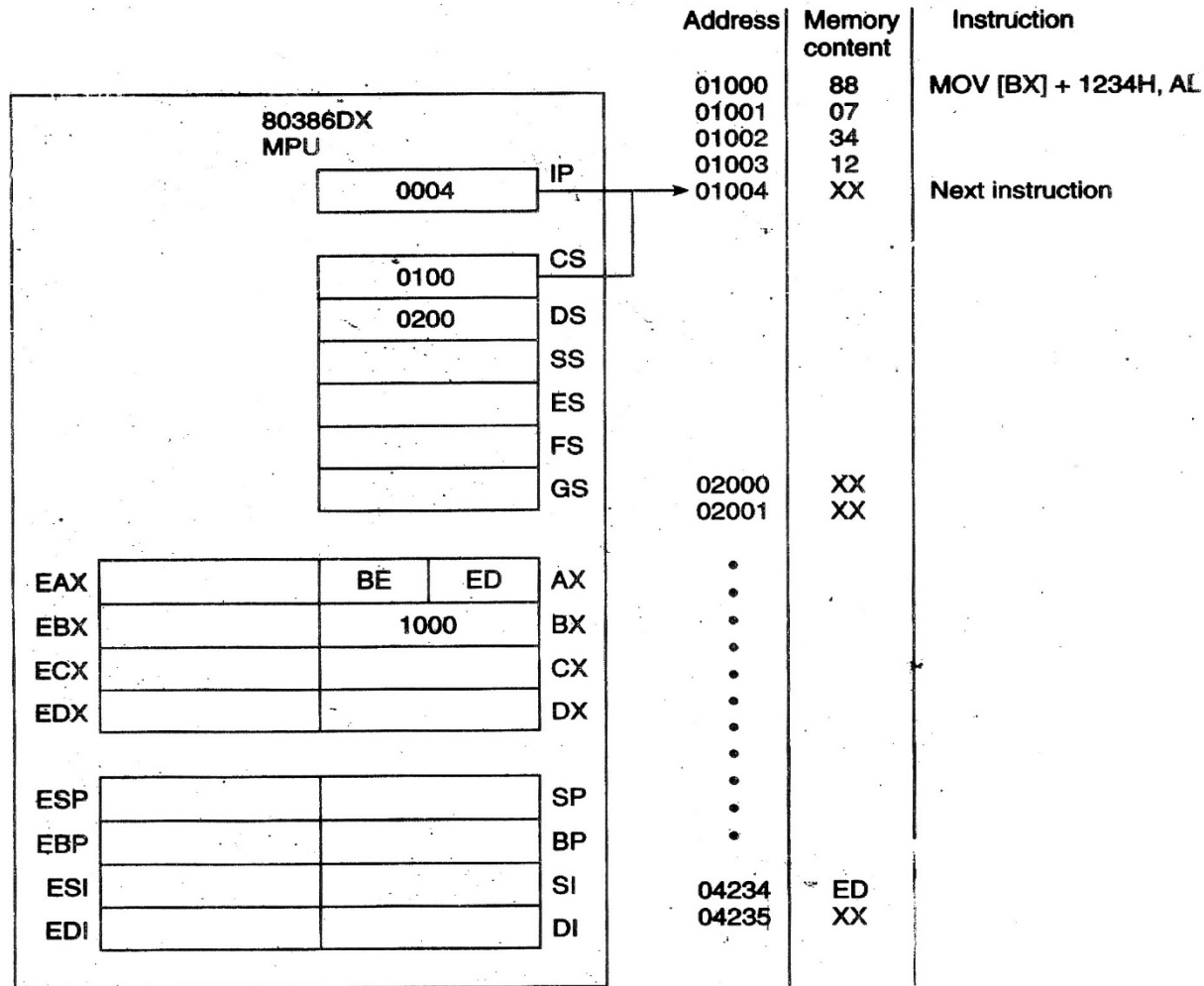

Figure 3.17 (a) Instruction using direct base pointer addressing mode before fetch and execution. (b) After execution.



(b)

Figure 3.17 (Continued)



Based relative addressing mode

In the based relative addressing mode, base registers BX and BP, as well as a displacement value, are used to calculate what is called the effective address. The default segments used for the calculation of the physical address (PA) are DS for BX and SS for BP. For example:

```
MOV    CX,[BX]+10    ;move DS:BX+10 and DS:BX+10+1 into CX  
                ;PA = DS (shifted left) + BX + 10
```

Alternative codings are "MOV CX,[BX+10]" or "MOV CX,10[BX]". Again the low address contents will go into CL and the high address contents into CH. In the case of the BP register,

```
MOV    AL,[BP]+5     ;PA = SS (shifted left) + BP + 5
```

Again, alternative codings are "MOV AL,[BP+5]" or "MOV AL,5[BP]".



6. Indexed addressing mode

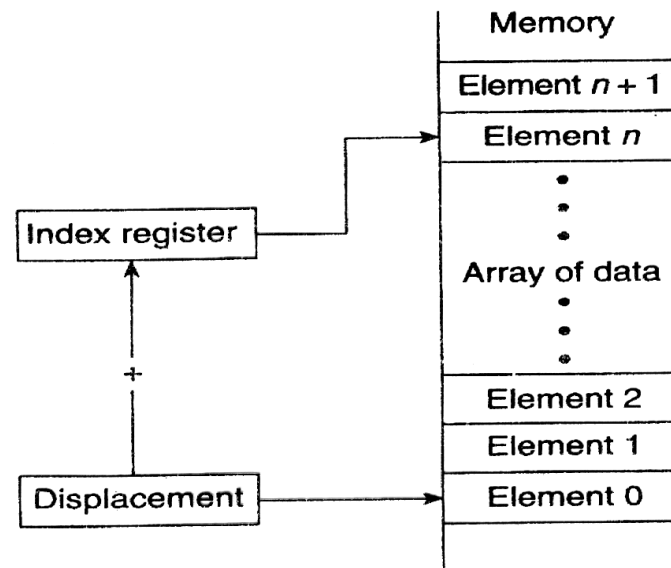

(a)

PA = Segment base: index + displacement

$$PA = \left\{ \begin{array}{l} CS \\ DS \\ SS \\ ES \\ FS \\ GS \end{array} \right\} : \left\{ \begin{array}{l} SI \\ DI \end{array} \right\} + \left\{ \begin{array}{l} 8\text{-bit displacement} \\ 16\text{-bit displacement} \end{array} \right\}$$

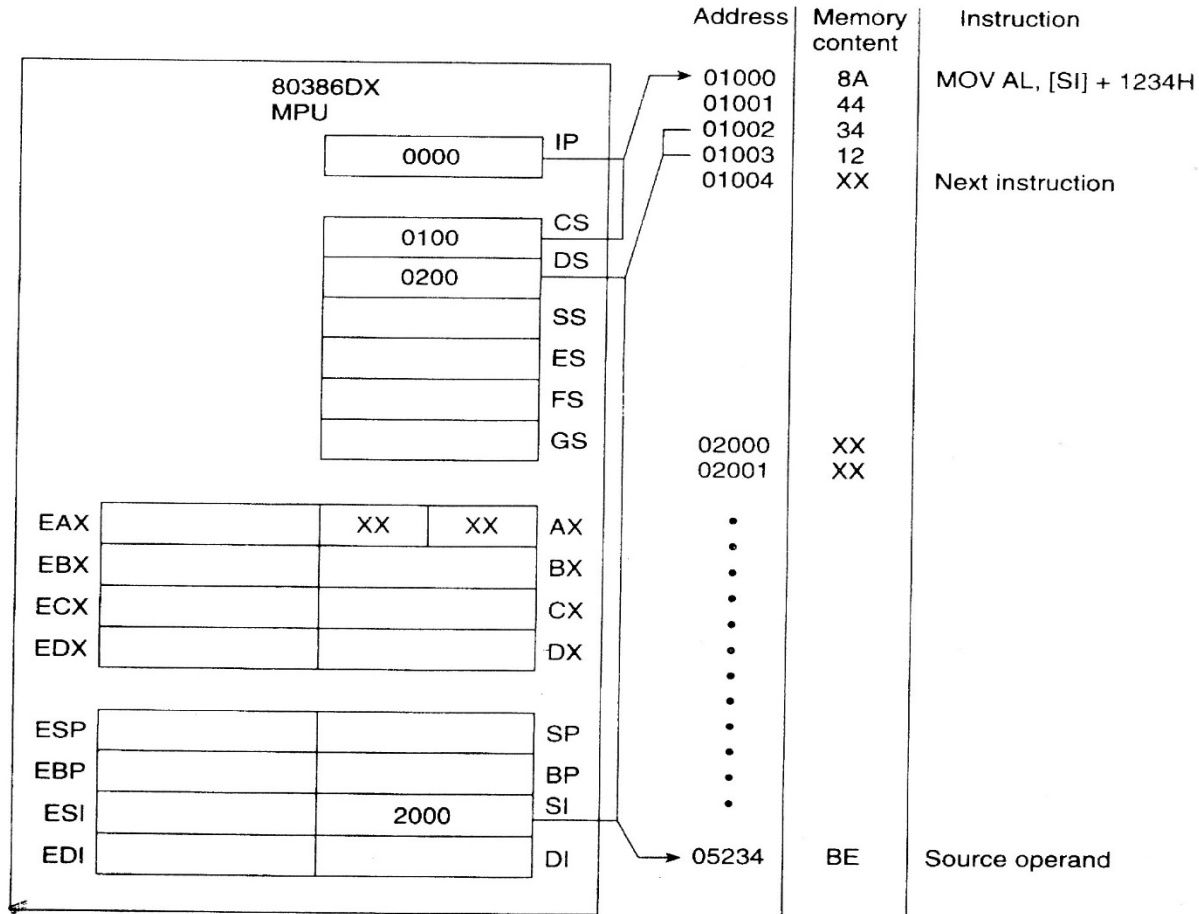

(a)

Figure 3.19 (a) Instruction using direct indexed addressing mode before fetch and execution. (b) After execution.

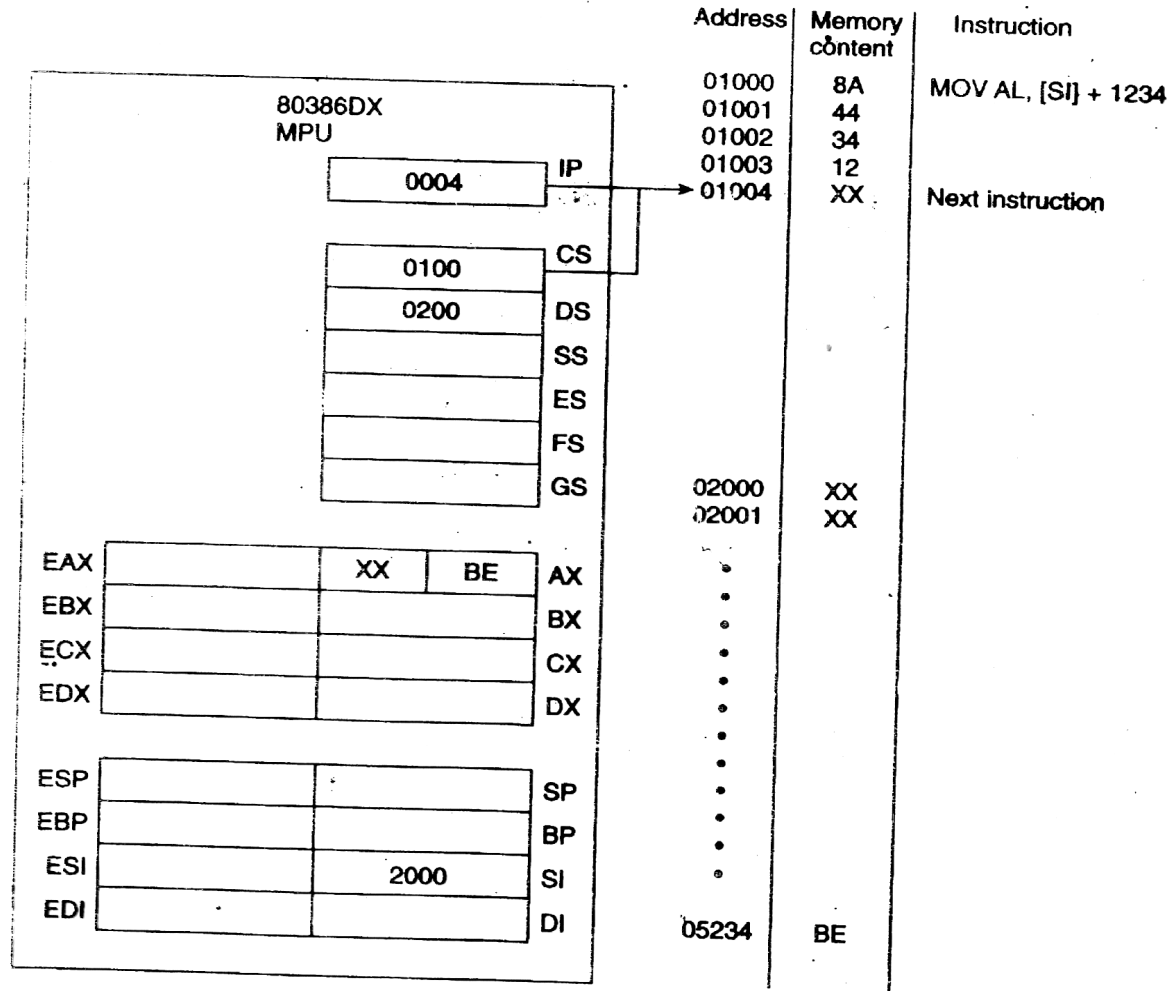

(b)

Figure 3.19 (Continued)

Example 1-17

Assume that DS = 4500, SS = 2000, BX = 2100, SI = 1486, DI = 8500, BP = 7814, and AX = 2512. Show the exact physical memory location where AX is stored in each of the following. All values are in hex.

- (a) MOV [BX]+20,AX (b) MOV [SI]+10,AX
(c) MOV [DI]+4,AX (d) MOV [BP]+12,AX

Solution:

In each case PA = segment register (shifted left) + offset register + displacement.

- (a) DS:BX+20 location 47120 = (12) and 47121 = (25)
(b) DS:SI+10 location 46496 = (12) and 46497 = (25)
(c) DS:DI+4 location 4D504 = (12) and 4D505 = (25)
(d) SS:BP+12 location 27826 = (12) and 27827 = (25)



7. Based-Indexed Addressing Mode

PA = Segment base: base + index + displacement

$$PA = \left\{ \begin{array}{l} CS \\ DS \\ SS \\ ES \\ FS \\ GS \end{array} \right\} : \left\{ \begin{array}{l} BX \\ BP \end{array} \right\} + \left\{ \begin{array}{l} SI \\ DI \end{array} \right\} + \left\{ \begin{array}{l} 8\text{-bit displacement} \\ 16\text{-bit displacement} \end{array} \right\}$$

(b)

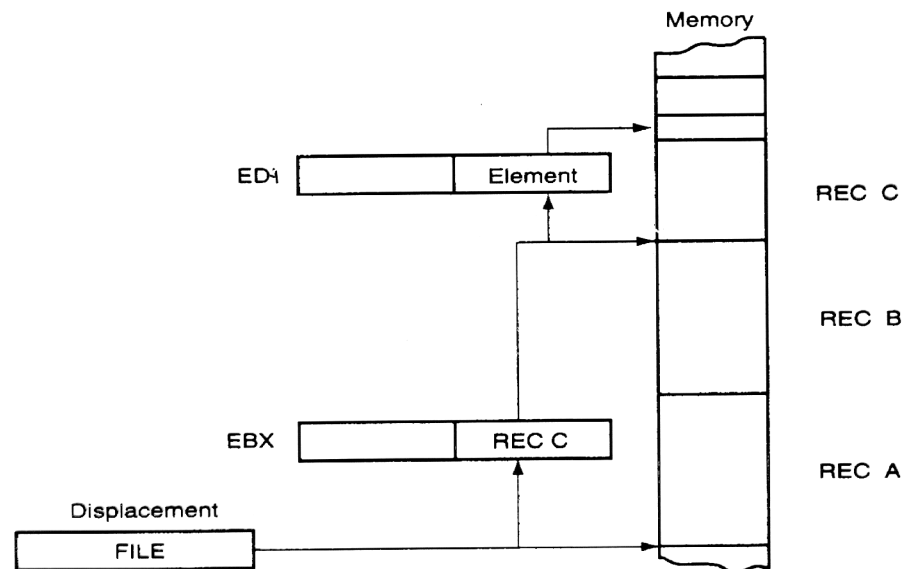

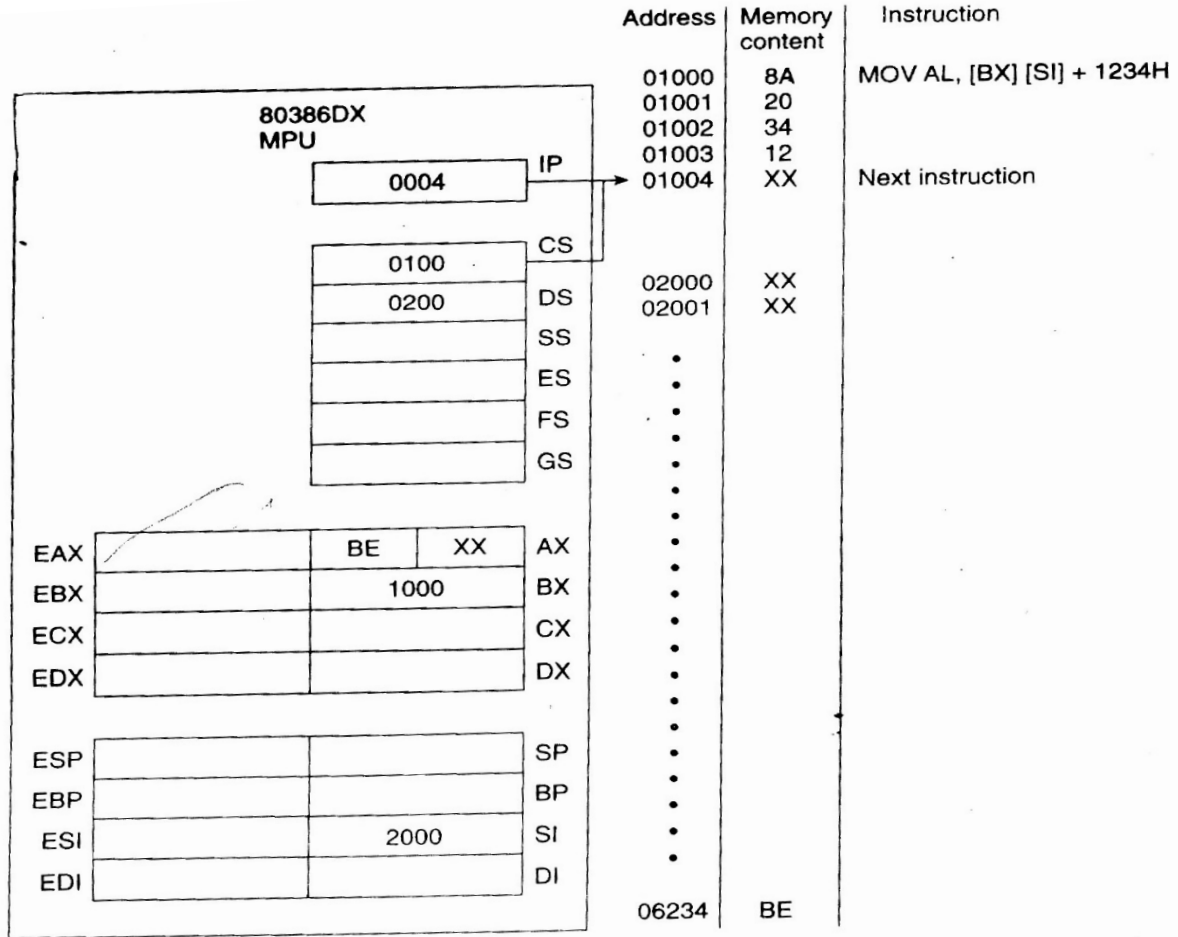

(b)

Figure 3.21 (Continued)



Based indexed addressing mode

By combining based and indexed addressing modes, a new addressing mode is derived called the based indexed addressing mode. In this mode, one base register and one index register are used. Examples:

MOV	CL,[BX][DI]+8	;PA = DS (shifted left) + BX + DI + 8
MOV	CH,[BX][SI]+20	;PA = DS (shifted left) + BX + SI + 20
MOV	AH,[BP][DI]+12	;PA = SS (shifted left) + BP + DI + 12
MOV	AH,[BP][SI]+29	;PA = SS (shifted left) + BP + SI + 29

The coding of the instructions above can vary; for example, the last example could have been written

MOV	AH,[BP+SI+29]	
or		
MOV	AH,[SI+BP+29]	;the register order does not matter.



Example 21-4

Show how data is placed after execution of the following code.

```
MOV EAX,7698E39FH      ;EAX=7698E39F
MOV [4524],AX
MOV [8000],EAX
```

Solution:

For "MOV [4524],AX" we have

DS:4524 =(9F)

DS:4525 =(E3)

and for "MOV [8000],EAX" we have

DS:8000 = (9F)

DS:8001 = (E3)

DS:8002 = (98)

DS:8003 = (76)



8. Scaled-Index Addressing Mode

$$PA = \text{Segment base: } \left\{ \text{Base} + (\text{Index} \times \text{Scale factor}) + \text{Displacement} \right\}$$

$$PA = \left\{ \begin{array}{c} \text{CS} \\ \text{SS} \\ \text{DS} \\ \text{ES} \\ \text{FS} \\ \text{GS} \end{array} \right\} : \left\{ \begin{array}{c} \text{AX} \\ \text{BX} \\ \text{CX} \\ \text{DX} \\ \text{SP} \\ \text{BP} \\ \text{SI} \\ \text{DI} \end{array} \right\} + \left\{ \begin{array}{c} \text{AX} \\ \text{BX} \\ \text{CX} \\ \text{DX} \\ \text{BP} \\ \text{SI} \\ \text{DI} \end{array} \right\} \times \left\{ \begin{array}{c} 1 \\ 2 \\ 4 \\ 8 \end{array} \right\} + \left\{ \begin{array}{l} \text{8-bit displacement} \\ \text{16-bit displacement} \end{array} \right\}$$

Figure 3.22 32-bit address mode physical and effective address computation for memory operands.



32-bit memory operand addressing mode

PA = Segment base: Indirect address

$$PA = \left\{ \begin{array}{c} CS \\ DS \\ SS \\ ES \\ FS \\ GS \end{array} \right\} : \left\{ \begin{array}{c} AX \\ BX \\ CX \\ DX \\ SP \\ BP \\ SI \\ DI \end{array} \right\}$$

(a)

PA = Segment base: Base + Displacement

$$PA = \left\{ \begin{array}{c} CS \\ DS \\ SS \\ ES \\ FS \\ GS \end{array} \right\} : \left\{ \begin{array}{c} AX \\ BX \\ CX \\ DX \\ SP \\ BP \\ SI \\ DI \end{array} \right\} + \left\{ \begin{array}{l} 8\text{-bit displacement} \\ 16\text{-bit displacement} \end{array} \right\}$$

(b)

PA = Segment base: (Index × Scale factor) + Displacement

$$\left\{ \begin{array}{c} CS \\ DS \\ SS \\ ES \\ FS \\ GS \end{array} \right\} : \left\{ \begin{array}{c} AX \\ BX \\ CX \\ DX \\ BP \\ SI \\ DI \end{array} \right\} \times \left\{ \begin{array}{c} 1 \\ 2 \\ 4 \\ 8 \end{array} \right\} + \left\{ \begin{array}{l} 8\text{-bit displacement} \\ 16\text{-bit displacement} \end{array} \right\}$$

(c)

PA = Segment base: Base + (Index × Scale factor) + Displacement

$$PA = \left\{ \begin{array}{c} CS \\ DS \\ SS \\ ES \\ FS \\ GS \end{array} \right\} : \left\{ \begin{array}{c} AX \\ BX \\ CX \\ DX \\ SP \\ BP \\ SI \\ DI \end{array} \right\} + \left\{ \begin{array}{c} AX \\ BX \\ CX \\ DX \\ BP \\ SI \\ DI \end{array} \right\} \times \left\{ \begin{array}{c} 1 \\ 2 \\ 4 \\ 8 \end{array} \right\} + \left\{ \begin{array}{l} 8\text{-bit displacement} \\ 16\text{-bit displacement} \end{array} \right\}$$

(d)

Figure 3.23 (a) 32-bit mode indirect memory-address computation. (b) 32-bit mode-based memory-address computation. (c) 32-bit mode scaled-index memory-address computation. (d) 32-bit mode scaled-based-index memory-address computation.



Table 1-4: Sample Segment Overrides

Instruction	Segment Used	Default Segment
MOV AX,CS:[BP]	CS:BP	SS:BP
MOV DX,SS:[SI]	SS:SI	DS:SI
MOV AX,DS:[BP]	DS:BP	SS:BP
MOV CX,ES:[BX]+12	ES:BX+12	DS:BX+12
MOV SS:[BX][DI]+32,AX	SS:BX+DI+32	DS:BX+DI+32



Table 1-5: Summary of 80x86 Addressing Modes

Addressing Mode	Operand	Default Segment
Register	reg	none
Immediate	data	none
Direct	[offset]	DS
Register indirect	[BX]	DS
	[SI]	DS
	[DI]	DS
Based relative	[BX]+disp	DS
	[BP]+disp	SS
Indexed relative	[DI]+disp	DS
	[SI]+disp	DS
Based indexed relative	[BX][SI]+disp	DS
	[BX][DI]+disp	DS
	[BP][SI]+ disp	SS
	[BP][DI]+ disp	SS



Table 8-2: Addressing Modes for the 80386/486

Addressing Mode	Operand	Default Segment
Register	register	none
Immediate	data	none
Direct	[OFFSET]	DS
Register indirect	[BX]	DS
	[SI]	DS
	[DI]	DS
	[EAX]	DS
	[EBX]	DS
	[ECX]	DS
	[EDX]	DS
	[ESI]	DS
[EDI]	DS	
Based relative	[BX]+disp	DS
	[BP]+disp	SS
	[EAX]+disp	DS
	[EBX]+disp	DS
	[ECX]+disp	DS
	[EDX]+disp	DS
	[EBP]+disp	SS
Indexed relative	[DI]+disp	DS
	[SI]+disp	DS
	[EDI]+disp	DS
	[ESI]+disp	DS
Based indexed relative	[R1][R2]+disp where R1 and R2 are any of the above	If BP is used, segment is SS; otherwise, DS is the segment

Note: In based indexed relative addressing, disp is optional.



Example 21-5

Find the effective address in each of the following cases. Assume that $ESI = 200H$, $ECX = 100H$, $EBX = 50H$, and $EDI = 100H$.

(a) $MOV AX, [2000+ESI*4]$

(b) $MOV AX, [5000+ECX*2]$

(c) $MOV ECX, [2400+EBX*4]$

(d) $MOV DX, [100+EDI*8]$

Solution:

(a) EA (effective address) is $2000H + 200H \times 4 = 2000 + 800H = 2800H$. Therefore, the logical address of the operand moved into AX is DS:2800H.

(b) By the same token we have $EA = 5000H + 100H \times 2 = 5000H + 200 = 5200H$.

(c) $EA = 2400H + 4 \times 50H = 2400H + 140H = 2540H$.

(d) $100H + 8 \times 100H = 100H + 800H = 900H$.