



## Al Mustaqbal University College



<b>STUDENT NAME:</b>	
<b>TUTOR NAME:</b>	<b>Dr. Ameer Al-khaykan</b>
<b>PROGRAMME:</b>	Electrical Circuit
<b>SUBJECT:</b>	Electrical and Electronics
<b>COURSEWORK TITLE:</b>	Series and parallel Resistor's connection

<b>Issue Date:</b>	<b>Due Date:</b>	<b>Feedback Date:</b>	<b>Extension Date:</b>
--------------------	------------------	-----------------------	------------------------

### PERFORMANCE CRITERIA:

#### TARGETED LEARNING OUTCOMES

4. Solve problems involving basic analogue and digital electronic circuits using numerical skills appropriate to an engineer.
5. Identify and safely use standard laboratory equipment to extract data, then apply in the solution of an electronic or electrical engineering problem.
6. Adopt a logical approach to the solution of engineering problems.

### Important Information – Please Read Before Completing Your Work

All students should submit their work by the date specified using the procedures specified in the Student Handbook. An assessment that has been handed in after this deadline will be marked initially as if it had been handed in on time, but the Board of Examiners will normally apply a lateness penalty.

Your attention is drawn to the Section on Academic Misconduct in the Student's Handbook.

All work will be considered as individual unless collaboration is specifically requested, in which case this should be explicitly acknowledged by the student within their submitted material.

Any queries that you may have on the requirements of this assessment should be e-mailed to dr.ameer  
No queries will be answered after respective submission dates.

You must ensure you retain a copy of your completed work prior to submission.

## MARKING CRITERIA

### COURSEWORK WILL BE MARKED ACCORDING TO THE FOLLOWING UNIVERSITY CRITERIA.

**90-100%:** a range of marks consistent with a first where the work is exceptional in all areas;

**80-89%:** a range of marks consistent with a first where the work is exceptional in most areas.

**70-79%:** a range of marks consistent with a first. Work which shows excellent content, organisation and presentation, reasoning and originality; evidence of independent reading and thinking and a clear and authoritative grasp of theoretical positions; ability to sustain an argument, to think analytically and/or critically and to synthesise material effectively.

**60-69%:** a range of marks consistent with an upper second. Well-organised and lucid coverage of the main points in an answer; intelligent interpretation and confident use of evidence, examples and references; clear evidence of critical judgement in selecting, ordering and analysing content; demonstrates some ability to synthesise material and to construct responses, which reveal insight and may offer some originality.

**50-59%:** a range of marks consistent with lower second; shows a grasp of the main issues and uses relevant materials in a generally business-like approach, restricted evidence of additional reading; possible unevenness in structure of answers and failure to understand the more subtle points: some critical analysis and a modest degree of insight should be present.

**40-49%:** a range of marks which is consistent with third class; demonstrates limited understanding with no enrichment of the basic course material presented in classes; superficial lines of argument and muddled presentation; little or no attempt to relate issues to a broader framework; lower end of the range equates to a minimum falls short in one or more areas.

**35-39%:** achieves many of the learning outcomes required for a mark of 40% but falls short in one or more areas.

**30-34%:** a fail; may achieve some learning outcomes but falls short in most areas; shows considerable lack of understanding of basic course material and little evidence of research.

**0-29%:** a fail; basic factual errors of considerable magnitude showing little understanding of basic course material; falls substantially short of the learning outcomes for compensation.

**Note:**

- While constructing circuits all connects should be made with the power supply in the off position.
- Check power and ground connections (and other connections) **before** switch on the power.
- Make sure that the power and the ground are properly connected to all IC's before switch on the power.
- **DO NOT** strip wire ends longer than 1/4" and jam long bare ends into the breadboard holes. This will cause shorts and ruin the board.
- **DO NOT** short (connect) the power supply outputs together, i.e., do not allow the exposed wires to touch each other. This will cause permanent damage to the power supply.
- **DO NOT** connect the power supply to the breadboard with reverse polarity. This will cause the permanent chip damage.
- **DO NOT** connect an output of any gate to the output of another gate, to a switch, to power (+5V), or to ground. These situations will cause excessive currents and result in the permanent damage to the chip or chips involved.

**Objective :**

To study the properties of series and parallel connection.

Tools needed:-

1. DC voltage supply.
1. Set of wires.
2. Resistances.
3. Multi-meter.

Theory :

1. The Series Circuit

A SERIES CIRCUIT or “series-connected circuit” is a circuit having JUST ONE CURRENT PATH. Thus, Fig.(1) is an example of a “series circuit” in which a battery of constant potential difference  $V$  volts, and three resistances, are all connected “in series”.

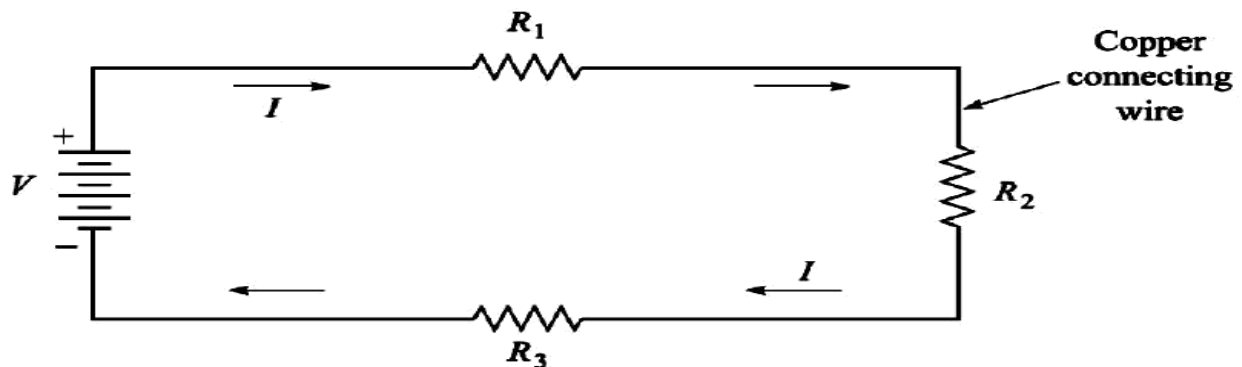

**Fig.(1)**

Since a series circuit has just one current path, it follows that all the components in a series circuit CARRY THE SAME CURRENT  $I$ , a fact evident from inspection of Fig.(1).

The current  $I$  is assumed to be a flow of positive charge, and thus flows out of the positive terminal of the battery and around through the external circuit, re-entering the battery at the negative terminal. This is indicated by the arrows in Fig.(1).

In a series circuit, the TOTAL resistance,  $R_T$ , that the battery sees is equal to the SUM of the individual resistances. Thus, in the particular case of Fig.(1) the battery sees a total resistance,  $R_T = R_1 + R_2 + R_3$ , while in the general case of “ $n$ ” resistances connected in series the battery sees a total resistance of :

$$R_T = R_1 + R_2 + R_3 + \dots + R_n$$

By Ohm’s law, it follows that the current  $I$  in a series circuit is equal to

$$I = \frac{V}{R_T} = \frac{V}{R_1 + R_2 + \dots + R_n}$$

Resistance, on the other hand, consumes electrical energy, removing it from the circuit in the form of heat. Since resistance does not produce or generate electrical energy, it is a non-active or PASSIVE type of circuit element.

The potential difference between the terminals of a resistor is called the VOLTAGE DROP across the resistor, and, is equal to the current  $I$  times the resistance  $R$ ; that is, the “voltage drop” across a resistance of  $R$  ohms carrying a current of  $I$  amperes is  $I \cdot R$  volts.

$$V = IR_T$$

$$V = I(R_1 + R_2 + \dots + R_n)$$

$$V = IR_1 + IR_2 + \dots + IR_n$$

We have the important fact that:

**In a series circuit, the applied voltage is equal to the sum of the**

It should be pointed out that the voltage drop across a resistor is always from plus to minus in the direction of the current flow, a fact illustrated in Fig.(2).

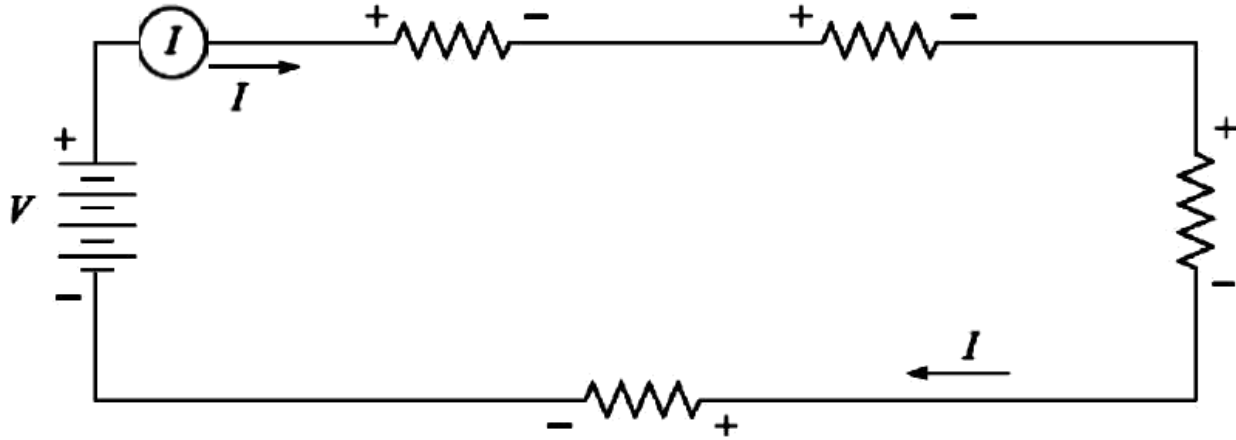

Fig.(2)

## 2. The Parallel Circuit

A PARALLEL circuit is one in which the battery current divides into a number of “parallel paths.” This is shown in Fig.(3), in which a battery, of constant  $V$  volts, delivers a current of  $I$  amperes to a load consisting of any number of  $n$  resistances connected “in parallel.”

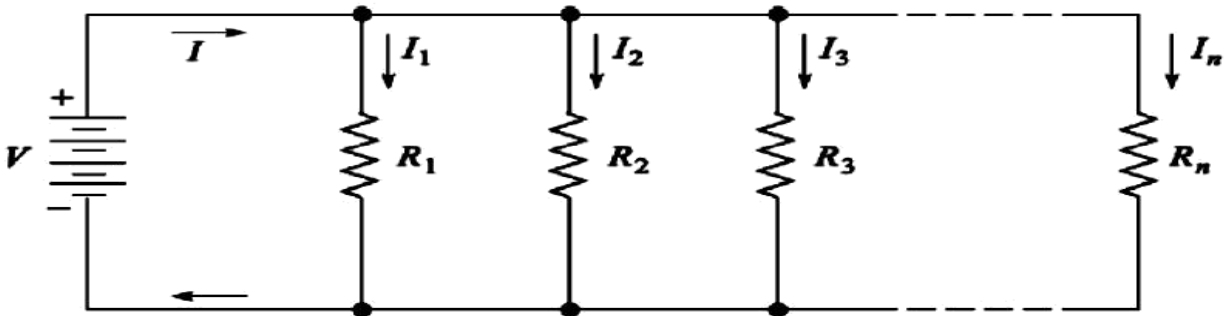

Fig.(3)

The currents in the individual resistances are called the “branch currents,” and the battery current  $I$  is often called the “line current.” From inspection of Fig.(3) we see that, in a parallel circuit, the battery current  $I$  is equal to the sum of the branch currents.

$$I = I_1 + I_2 + I_3 + \cdots + I_n$$

If the battery voltage  $V$  is applied equally to all  $n$  resistances; that is, the same voltage  $V$  is applied to all the parallel branches. Hence, by Ohm’s law, the individual branch currents in Fig.(3) have the values:

$$I_1 = V/R_1, \quad I_2 = V/R_2, \dots, I_n = V/R_n$$

Then, we have:

$$I = V \left( \frac{1}{R_1} + \frac{1}{R_2} + \frac{1}{R_3} + \cdots + \frac{1}{R_n} \right)$$

Now let  $R_T$  be the total resistance as seen by the battery in Fig.(3).

Then, by Ohm’s law, it has to be true that:

$$I = \frac{V}{R_T}$$

Since the left-hand sides of the last two equations are equal, the two right-hand sides are also equal. Setting the two right-hand sides equal, then canceling the  $V$ s, gives :

$$\boxed{\frac{1}{R_T} = \frac{1}{R_1} + \frac{1}{R_2} + \frac{1}{R_3} + \cdots + \frac{1}{R_n}}$$

Procedure

- Using the DC circuit trainer, connect the circuit Shown in Fig. (4), take  $V_T = 10V$ , and  $R_1 = 1k\Omega$ ,  $R_2 = 100\Omega$  and  $R_3 = 2k\Omega$ .
- Measured the voltage and current of "R1 , R2 & R3", then record it in table below :

	<b>1k<math>\Omega</math></b>	<b>100<math>\Omega</math></b>	<b>2k<math>\Omega</math></b>	
<b>V(volt)</b>				<b>V<sub>T</sub> =</b>
<b>I(mA)</b>				<b>I<sub>T</sub> =</b>

- By using ohm's law, Calculate the  $R_T$  .
- Disconnect the DC power supply, and then measured the equivalent resistance by using the Multi-meter only.

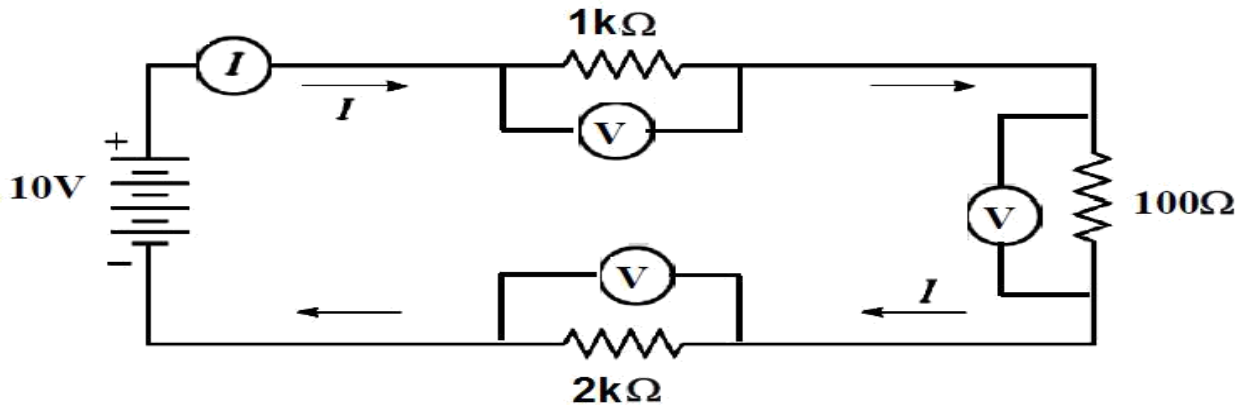

**Fig.(4)**

5. Repeat the procedure in steps ( 1,2,3&4) above , for the circuit shown in Fig.(5).

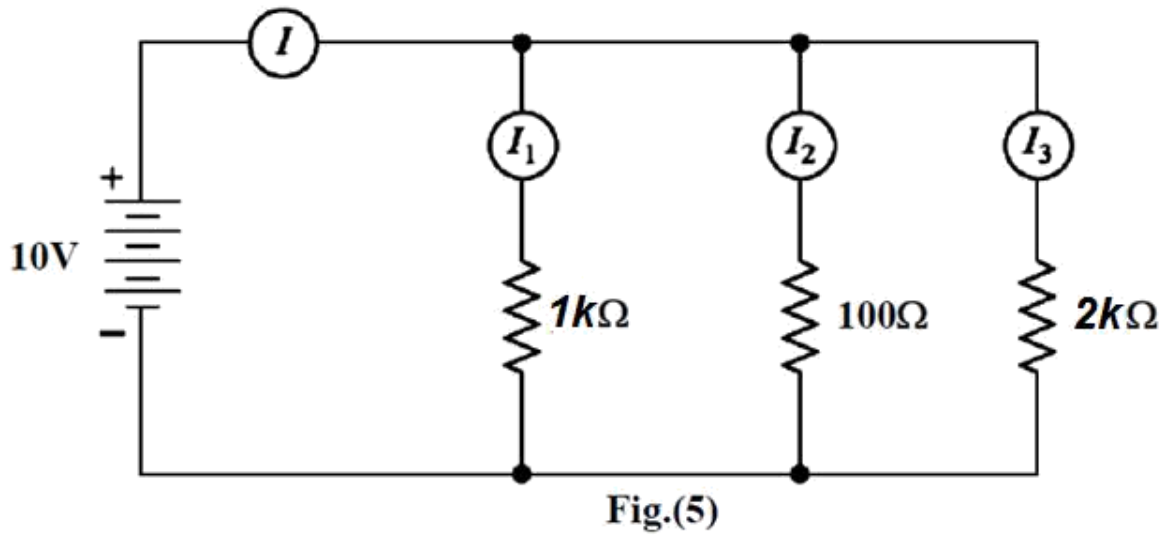

Discussion

1. Two resistors (R1, R2) are connect in parallel, prove that

$$R_T = \frac{R_1 R_2}{R_1 + R_2}$$

2. For the circuit shown below, find RT, V2.

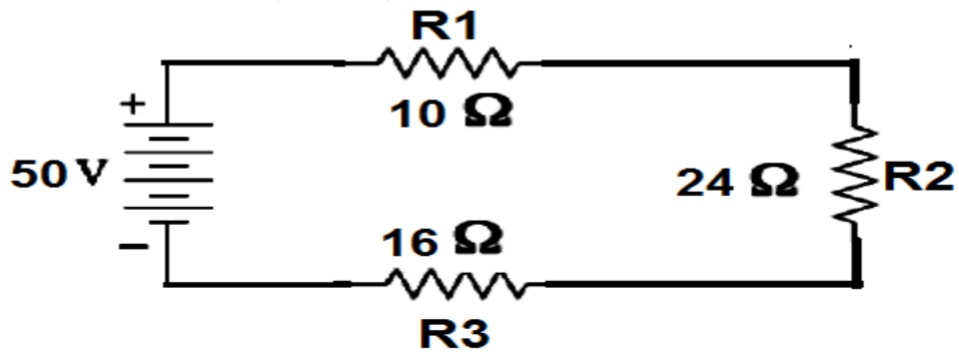



3. In Figure below, the battery voltage is  $V = 65$  volts, and the values of the resistances, in ohms, are 38, 17, and 27, as shown. Find:
- (a) Total resistance seen by the battery,
  - (b) Current measured by the ammeters shown in the figure,
  - (c) Power output of the battery,
  - (d) Power input to each resistor.

