



## EXP.NO: 2

### Name of experiment: **Half-Wave Rectifier (HWR)**

#### Purpose of experiment:

- Construct the half-wave rectifier circuit.
- Measure/plot the input and output waveform.
- Find the peak and average value of the output signal

**Apparatus:** AC power supply (Function generator) or standard transformer. Breadboard, Semiconductor Diode, and  $1K\Omega$  Resistor.

#### Theory:

Because of the diode's ability to conduct current in one direction and block current in the other direction, diodes are used in circuits called rectifiers that convert AC voltage into DC voltage. Rectifiers are found in all dc power supplies that operate from an Ac voltage source.

In Fig.2.1, a diode is connected to an AC source that provides the input voltage  $V_{in}$  to a load resistor  $R_L$ , forming a half-wave rectifier.

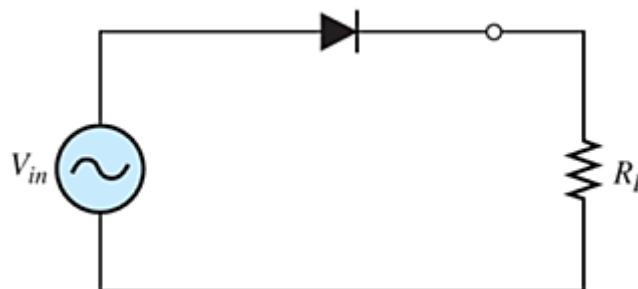

**Figure.2.1: Half-wave rectifier circuit**

When the sinusoidal input voltage goes positive, the diode  $D$  is forward-biased and conducts current through the load resistor  $R_L$ , as shown in Fig.2.2. The current produces an output voltage across the load  $R_L$ , which has the same shape as the positive half-cycle of the input voltage.

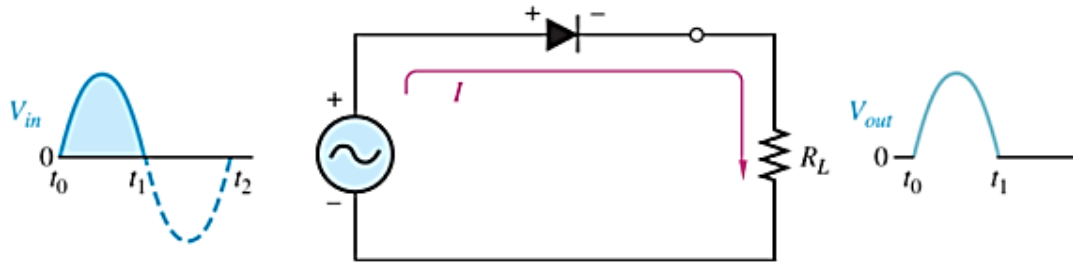

**Figure.2.2. Operation during positive alternation of the input voltage**

When the input voltage goes negative during the second half of its cycle, the diode is reverse-biased. There is no current, so the voltage across the load resistor  $R_L$  is zero, as shown in Fig.2.3.

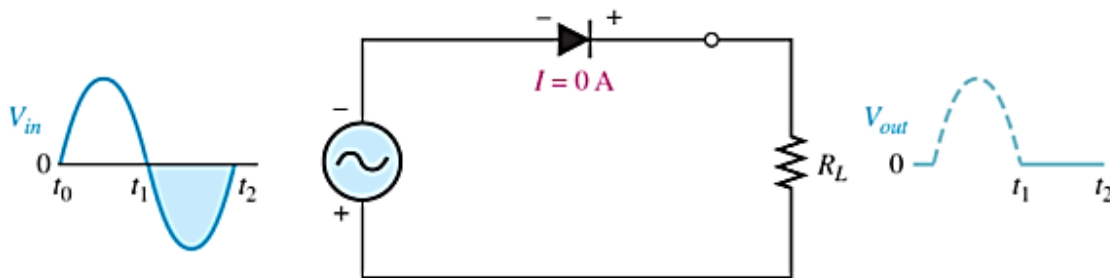

**Figure 2.3. Operation during negative alternation of the input voltage**

The net result is that only the positive half-cycles of the ac input voltage appear across the load. Since the output does not change polarity, it is a pulsating DC voltage, as shown in Fig.2.4.

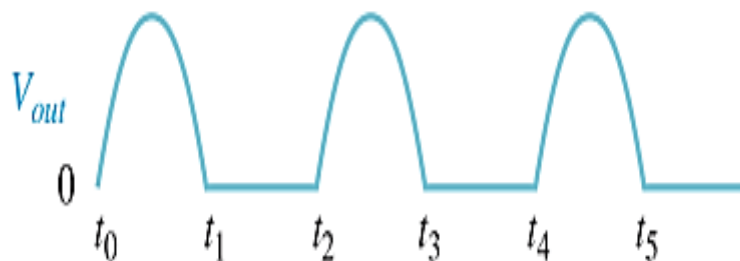

**Figure 2.4. Half-wave output voltage for three input cycles**



## Average Value of the Output Voltage

The average value of a half-wave rectified output voltage is the value you would measure on a DC voltmeter. It can be calculated with the following equation, where  $V_p(out)$  is the peak value of the half-wave rectified output voltage:

$$V_{AVG} = \frac{V_p(out)}{\pi}$$

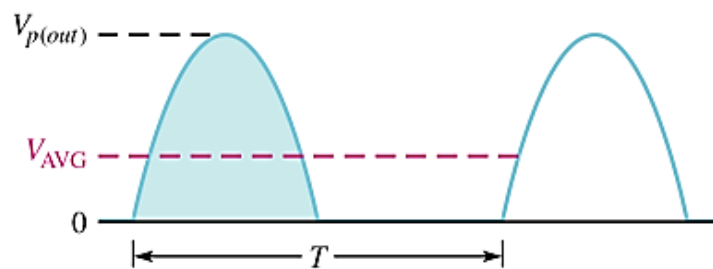

Figure 2.5: Shows the half-wave voltage with its average value indicated by the red dashed line

## Procedure

1. Connect the circuit as shown in Fig.2.1 using an AC power supply (Function generator) or standard transformer, a diode, a 1k $\Omega$  resistor (RL)
2. Apply  $V_{p.p} = 10$  V and a frequency of 50 Hz.
3. Display the input and output signal on the oscilloscope.
4. Tabulate your measurement result in a table as shown.

Load	V(v)	I(mA)
50 ohm		
75 ohm		
100 ohm		
150 ohm		
200 ohm		
500 ohm		

## Discussion

1. Why the VAVG of the input signal is close to zero?



2. On a graphic paper, draw the input and output signals, both on one chart (on top of each other). Indicating the voltages ( $V_p$ ,  $V_{rms}$ , and  $V_{AVG}$ ).
3. What would be the outcome if the diode is flipped? Why? Draw the output signal.



### EXP.NO: 3

#### Name of experiment: Full-Wave Rectifier (FWR)

#### Purpose of experiment:

A full wave rectifier is defined as a rectifier that converts the complete cycle of alternating current into pulsating DC.

#### Apparatus:

AC power supply or standard transformer. Breadboard, 2 Semiconductor Diode, and 1KΩ Resistor, Connecting Wires.

#### Theory:

Unlike half wave rectifiers that utilize only the half wave of the input AC cycle, full wave rectifiers utilize the full cycle. The lower efficiency of the half wave rectifier can be overcome by the full wave rectifier.

The circuit of the full wave rectifier can be constructed in two ways. The first method uses a center tapped transformer and two diodes. This arrangement is known as a center tapped full wave rectifier. The second method uses a standard transformer with four diodes arranged as a bridge. This is known as a bridge rectifier. In the next section, we will restrict the discussion to the centre tapped full wave rectifier only.

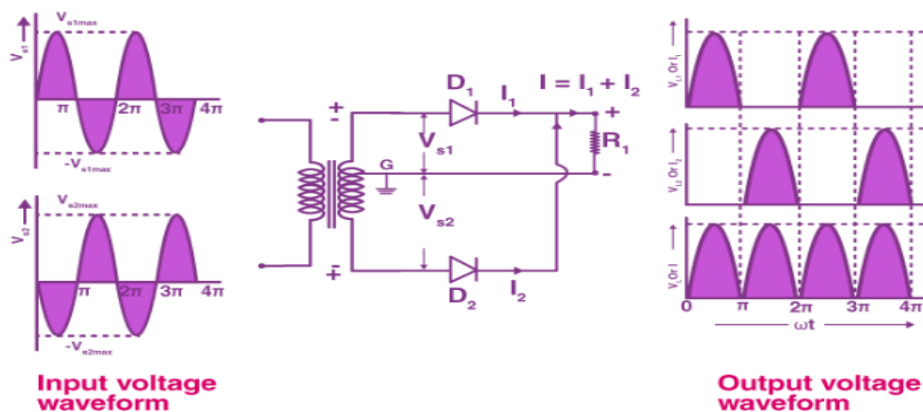

The circuit of the full wave rectifier consists of a step-down transformer and two diodes that are connected and center tapped. The output voltage is obtained across the connected load resistor.

#### Advantages of Full Wave Rectifier



- The rectification efficiency of full wave rectifiers is double that of half wave rectifiers. The efficiency of half wave rectifiers is 40.6% while the rectification efficiency of full wave rectifiers is 81.2%.
- The ripple factor in full wave rectifiers is low hence a simple filter is required. The value of ripple factor in full wave rectifier is 0.482 while in half wave rectifier it is about 1.21.
- The output voltage and the output power obtained in full wave rectifiers are higher than that obtained using half wave rectifiers.

The only disadvantage of the full wave rectifier is that they need more circuit elements than the half wave rectifier which makes, making it costlier.

### Procedure

1. Connect the circuit as shown in Fig.2.1 using an AC power supply (Function generator) or standard transformer, a diode, a 1kΩ resistor (RL)
2. Display the input and output signal on the oscilloscope.
3. Tabulate your measurement result in a table as shown.

Load	V(v)	I(mA)
50 ohm		
75 ohm		
100 ohm		
150 ohm		
200 ohm		
500 ohm		